

BERCHTOLD

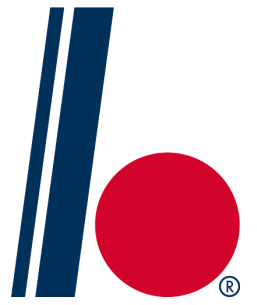

Pre-Installation Manual

**Examination light
CHROMOPHARE F 300**

CE

Read the instructions before beginning any work!

© BERCHTOLD Corporation
1950 Hanahan Road
Charleston, SC 29406

Phone: 843-569-6100
Phone: 800-243-5135
Fax: 843-569-6133

Table of Contents

1	Safety	5
1.1	Responsibility of the operator	5
1.2	Personnel requirements	6
1.3	Intended use	7
1.4	Reliability	8
1.5	Personal protective equipment	8
1.6	Specific risks	8
1.7	Environmental protection	10
1.8	Labelling	10
2	Technical data	11
2.1	General information	11
2.2	Connected loads	12
2.3	Operating conditions	13
2.4	Performance values	13
2.5	Emissions	14
2.6	Model plate	14
3	Design and function	15
3.1	Overview	15
3.1.1	CHROMOPHARE® F 300 Ceiling, double arm	15
3.1.2	CHROMOPHARE® F 300 Ceiling, single arm	16
3.1.3	CHROMOPHARE® F 300 Wall, double arm	17
3.1.4	CHROMOPHARE® F 300 Wall, single arm	18
3.1.5	CHROMOPHARE® F 300 Mobile	19
3.2	Short description	20
3.3	System Variants	21
3.4	Hazardous areas	22
3.5	Scope of delivery	22
4	Transport, packaging and storage	23
4.1	Transport safety instructions	23
4.2	Symbols on the packaging	23
4.3	Transport inspection	24
4.4	Packaging	24
4.5	Transport	25
5	Installation and initial start-up	27
5.1	Safety	27
5.2	Structural strength	29
5.3	Tools	30
5.4	Bearing lubrication	30
5.5	Ceiling CHROMOPHARE® F 300 Installation	30

Table of Contents

5.5.1	Anchor plate with reinforcement plate	30
5.5.2	Anchor plate and spacer block with heavy-duty anchors	32
5.6	Installing the spacer block	37
5.7	Installing a ceiling tube	37
5.8	Installing the soffit	38
5.9	Installation of horizontal arm (CHROMOPHARE® F 300 Ceiling, Double Arm) and spring arm (CHROMOPHARE® F 300 Ceiling, Single Arm)	39
5.10	Attaching the spring arm to the horizontal arm ((CHROMO- PHARE® F 300 Ceiling, Double Arm)	40
5.11	Wall CHROMOPHARE® F 300 Installation	42
5.11.1	Installing the wall bracket	42
5.12	Installation of horizontal arm (CHROMOPHARE® F 300 Wall, Dou- ble Arm) and spring arm (CHROMOPHARE® F 300 Wall, Single Arm)	49
5.13	Installation of Spring Arm to the Horizontal Arm ((CHROMO- PHARE® F 300 Wall, Double Arm)	50
5.14	Installation of CHROMOPHARE® F 300 Mobile	52
5.15	Mechanical adjustments	53
5.15.1	Diagrams	53
5.15.2	Fine-tuning the spring force in the spring arm	54
5.16	Connecting the electricity	55
5.16.1	CHROMOPHARE® F 300 Ceiling	56
5.16.2	CHROMOPHARE® F 300 Wall	56
5.17	Initial start-up	57
6	Appendix	58
6.1	Consumables	58
6.2	Dimensional drawings of ceiling anchor plates and spacer	58
6.2.1	Anchor Plate CHROMOPHARE® F 300 Ceiling	58
6.2.2	Wall Bracket for CHROMOPHARE® F 300 Wall	60
6.2.3	Spacer block	60
6.3	Fuses, terminal voltages	61
6.3.1	Fuses	61
6.3.2	Terminal voltages	62
6.4	Information on electromagnetic compatibility (EMC)	62
6.4.1	Guidelines and manufacturer's statement – electromag- netic emissions	63
6.4.2	Guidelines and manufacturer's statement – electromag- netic interference immunity	63
	65

1 Safety

This section provides an overview of all important safety information for optimal protection of personnel and safe, trouble-free operation.

Non-compliance with the operating and safety instructions in this manual can result in considerable danger.

1.1 Responsibility of the operator

The device is used in a commercial space. Therefore, the operator of the device is subject to legal workplace safety regulations.

In addition to the occupational safety warnings presented in this manual, the operator must observe all the safety, accident-prevention and environmental-protection regulations related to the field of application. In particular, the following apply:

- The operator must obtain information on the applicable health and safety regulations and also conduct a hazard assessment to identify hazards that arise from the particular working conditions at the place where the device is used. Such risks must be presented in the form of operating instructions.
- Throughout the period the device is used, the operator must check whether the operating instructions it has created correspond to the latest edition of the standard regulations and make adjustments as required.
- The operator must clearly regulate and establish the responsibilities for installation, operation, maintenance, and cleaning.
- The operator must ensure that all employees that work with the device have read and understood the manual.
- The operator must also train staff and inform them of the hazards at regular intervals.
- The operator must provide the staff with the protective equipment required.

The operator is also responsible for keeping the device in proper technical working order; the following applies:

- The operator must ensure that the maintenance intervals specified in this manual Maintenance schedule are observed.
- The operator must have the functional capability and completeness of all safety equipment inspected at regular intervals.

Safety

1.2 Personnel requirements



WARNING

Risk of injury if operated by insufficiently trained personnel!

Incorrect handling can result in serious bodily injury and property damage.

✓ Therefore:

1. All activities are to be carried out only by qualified personnel.
2. Consult the manufacturer if there is any doubt concerning maintenance activities.
3. Repairs should be done only by the manufacturer or authorized technical personnel.

The following qualifications apply for these various ranges of tasks:

▪ **Medical Specialists (Surgeons, Surgical Staff)**

are able to safely perform the assigned tasks by virtue of their medical training, knowledge and experience.

Medical specialists can independently detect, assess and avoid possible hazards to themselves or the patients.

Medical specialists know the content of all valid regulations, guidelines and standards required by law for safe use of the device and are able to implement them accordingly.

Medical specialists have the required technical knowledge for properly using the device in the area of application and comply with all hygiene regulations for rooms used for medical purposes and for the use of medical devices.

▪ **Installation personnel**

Only employees of BERCHTOLD or its authorised agents may install and perform the initial start-up of the product.

Due to the great weight and torque involved, the assembly of surgical lights requires trained specialist personnel with sufficient experience.

▪ **Qualified electricians**

, by virtue of their specialist training, knowledge and experience, as well as their knowledge of the relevant standards and provisions, are capable of carrying out work on electrical equipment and identifying and avoiding potential hazards for themselves.

Skilled electricians are trained specifically for the location in which they are deployed and are aware of the relevant standards and provisions.

1.3 Intended use

The device is designed and constructed exclusively for the use described herein.

CHROMOPHARE® surgical lights are medical lights for usage in hospital treatment rooms. They provide localized lighting focused on the patient's body for detecting and treating disease, injury, and disability.

The surgical lights may only be used in rooms used for medical purposes that have been equipped in accordance with

VDE 0100-710 or IEC 60364-7-10 in accordance with the regulations..



WARNING

Danger if not used as intended!

Dangerous situations can result any time the device is used for purposes beyond or other than those intended.

✓ Therefore:

1. Use the device only as intended.
2. Strictly adhere to all specifications in this operating manual.
3. Only BERCHTOLD personnel or technicians expressly authorized by BERCHTOLD may install, modify or repair the devices.

⇒ The following uses are prohibited, in particular:

4. Operation in areas where there is danger of explosion. The surgical lights are a potential source of ignition.
5. Operation with a damaged underglass or filter system.
6. Placement of objects on the light head or hanging objects from the swivel arms and light head.

Safety

Claims of any kind due to damage resulting from improper use are excluded. The operator is solely responsible for damages resulting from improper use.

1.4 Reliability

As single lights, CHROMOPHARE® examination lights are extremely reliable because the LED modules and their lamps are long-lasting.

1.5 Personal protective equipment

To minimise health risks, personal protective equipment must be worn while working.

- When working, always wear the protective equipment appropriate to the respective task.
- Observe the information on the personal protection equipment posted in the work area.

Protective equipment for special tasks

When performing specific work, special protective equipment is required. These tasks are discussed individually in the various sections of this manual. The special protective equipment covered is:



Goggles

Protect workers from any flying parts or sprays of liquids

1.6 Specific risks

The following section lists residual risks identified by a risk analysis.

- Observe the following safety instructions and the warnings in the sections below to reduce health hazards and avoid dangerous situations.

Electrical current



DANGER

Risk of electrocution!

Touching live electrical components is life threatening. Damage to insulation or individual components can cause fatal injury.

✓ Therefore:

1. If insulation is damaged, immediately cut off the power supply and initiate repairs.
2. Electrical work is to be performed by skilled electricians only.
3. For all work on the electrical system, disconnect it from the mains and check that it is free of voltage.
4. Before performing any maintenance, cleaning or repairs, turn off the power supply and secure it against accidental switch-on.
5. Do not bypass or deactivate fuses. Make sure the number of amperes is correct when changing fuses.
6. Keep conductive parts away from humidity. It can cause a short circuit.

EMC risks (flat screens)



WARNING

Use of non-EMC flat screens and switched-mode power supplies is life-threatening.

Radiation disturbances can skew measurement results of medical devices (e.g., monitoring of vital functions). This can result in life-threatening situations.

✓ Therefore:

1. Use only UL- or IEC-rated (UL60601-1, IEC 60601-1) flat screens and switched-mode power supplies.

Safety

1.7 Environmental protection



CAUTION

Environmental hazard from incorrect handling!

Incorrect handling of environmentally hazardous substances, especially incorrect disposal, can result in significant damage to the environment.

✓ Therefore:

1. Always observe the following instructions.
2. Take appropriate measures immediately should hazardous substances accidentally be released into the environment. In case of doubt, notify the responsible local authorities regarding the damage.

The following environmentally hazardous substances are used:

Lubricants

Lubricants such as grease and oil contain poisonous substances. They should not be released into the environment. Disposal must be handled by disposal specialists

1.8 Labelling



Electrical voltage (on the soffit)

Only skilled electricians may work in these areas.



Load limit (on the spring arm)

Never exceed the indicated permissible load limit.

2 Technical data

2.1 General information

The specifications for weight and max. torque refer to the lights (incl. power supply, ceiling tube or wall bracket) a 150 mm long ceiling tube (Ø 45 mm) and an 800 mm long horizontal arm. The details for the highest and lowest positions and the clearance heights are based on a ceiling height of 240 cm for ceiling lights and a mounting point at 220 cm (single arm) and 240 cm (double arm) for wall lights.

CHROMOPHARE® F 300 Ceiling, double arm

Specification	Value	Unit
Weight incl. power supply	17,64	lbs
Max. torque	70	Nm
Light head diameter	12,99	inch
Max. swivel radius	75,2	inch
Lowest position of light head	53,15	inch
Highest position of light head	90,55	inch
Clearance height	78,74	inch

CHROMOPHARE® F 300 Ceiling, single arm

Specification	Value	Unit
Weight incl. power supply	12,34	lbs
Max. torque	30	Nm
Light head diameter	12,99	inch
Max. swivel radius	43,31	inch
Lowest position of light head	59,06	inch
Highest position of light head	92,52	inch
Clearance height	85,04	inch

CHROMOPHARE® F 300 Wall, double arm

Specification	Value	Unit
Weight incl. power supply	17,64	lbs
Max. torque	70	Nm

Technical data

Specification	Value	Unit
Light head diameter	12,99	Inch
Max. swivel radius	77,95	Inch
Lowest position of light head	52,76	Inch
Highest position of light head	100	Inch
Clearance height	78,74	inch

CHROMOPHARE® F 300 Wall, single arm

Specification	Value	Unit
Weight incl. power supply	12,34	lbs
Max. torque	30	Nm
Light head diameter	12,99	inch
Max. swivel radius	46,46	inch
Lowest position of light head	52,76	inch
Highest position of light head	100	inch
Clearance height	78,74	inch

CHROMOPHARE® F 300 mobile

Specification	Value	Unit
Weight incl. power supply	46,29	lbs
Light head diameter	12,99	inch
Max. swivel radius	43,31	inch
Lowest position of light head	38,19	inch
Highest position of light head	90,55	inch

2.2 Connected loads

All models

Specification	Value	Unit
Power supply primary voltage	100-120	V (AC)
	220-240	V (AC)
Power consumption with mains operation	50	VA (AC)
Power consumption of the light head with DC supply	30	W (with 24 V DC)
AC frequency	50/60	Hz
Safety class	1	

Technical data

LEDs for CHROMOPHARE® F 300

The CHROMOPHARE® F 300 examination light is equipped with an advanced lamp, the LED ("Light Emitting Diode"). LEDs differ from conventional halogen or discharge lamps in that they have a very long service life. Conventional lamps normally have to be replaced after 1000 to 5000 operating hours, but LEDs have very long service lives, about 30,000 operating hours. In all, the CHROMOPHARE® F 300 consists of 7 LED modules with Fresnel optics.

2.3 Operating conditions

All models

Specification	Value	Unit
Ambient temperature	0...95	°F
Relative humidity, non-condensing	max. 90	%
Barometric pressure	10,15.....15,37	psi

2.4 Performance values

The technical data for the lights listed in the following tables are rated with a tolerance of $\pm 10\%$. The consistency of BERCHTOLD LED-Modules complies with IEC 60601-2-41, Section 51.102.4e.

All models

Specification	Value	Unit
Reflector system	LED technology with Fresnel optics	
Colour temperature	4500	K
Light intensity EC at a distance of 1 m	55	klx
Electronic brightness control	5	Levels
	20-100	%
Total radiant power at maximum intensity	170	W/m ²
Total radiant power/intensity	3,1	mW/(m ² lx)
Colour rendering index R _a	96	
Circadian action coefficient a _{cv}	0,68	

Technical data

Specification	Value	Unit
Light field diameter	6,3	inch
d ₁₀ Light field, Ø at 10 % of max. light intensity	6,3	inch
d ₅₀ Light field, Ø at 50 % of max. light intensity	3,35	inch
Depth of illumination L1 + L2	51,18	inch

2.5 Emissions

A full explanation on compliance with EMC guidelines can be found in the appendix.

2.6 Model plate

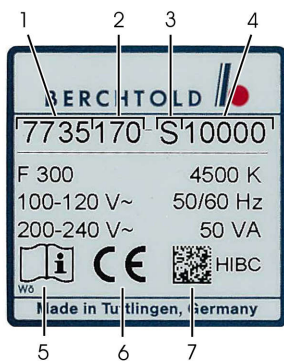

Fig. 1: Model plate

The model plate of the surgical light is located:

Mobile: on the cover (power supply)

Wall: on lamination (power supply)

Ceiling: on spring arm

It contains the following information:

- 1 Version number
- 2 Variant
- 3 Year of manufacture (A = 1993, B = 1994,...)
- 4 Sequential number
- 5 Attention, consult accompanying documents
- 6 CE certificate
- 7 Health Industry Bar Code

3 Design and function

3.1 Overview

3.1.1 CHROMOPHARE® F 300 Ceiling, double arm

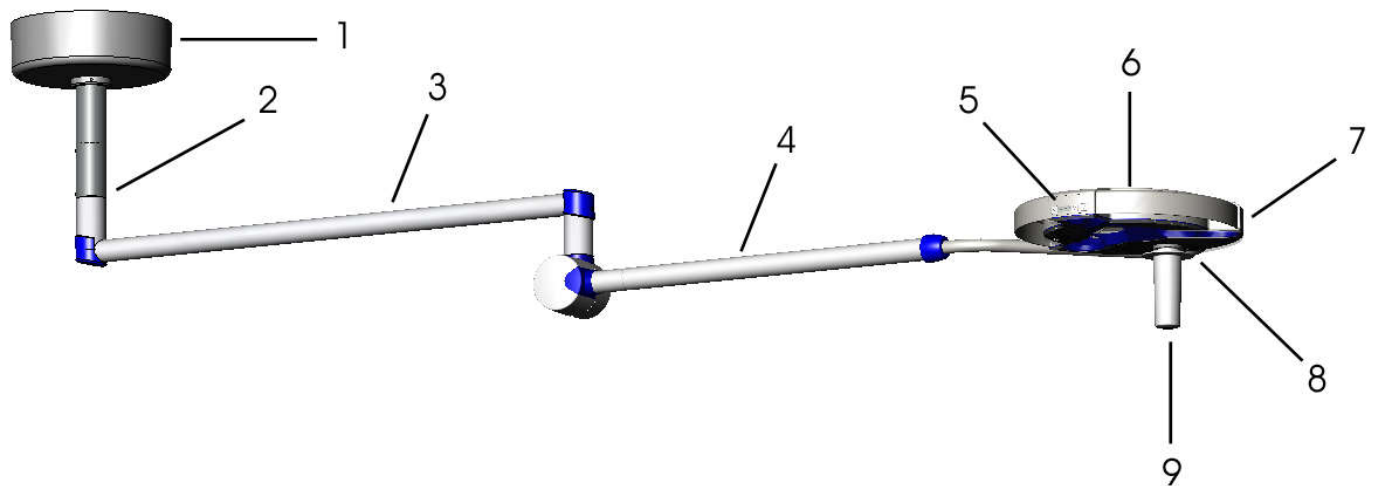

Fig. 2: Components of CHROMOPHARE® F 300 Ceiling, double arm

1	Soffit	6	Light head cover casing
2	Ceiling tube Ø 1,77 inch	7	Rail
3	Horizontal arm	8	Underglass
4	Spring arm	9	Handle
5	Control unit		

Design and function

3.1.2 CHROMOPHARE® F 300 Ceiling, single arm

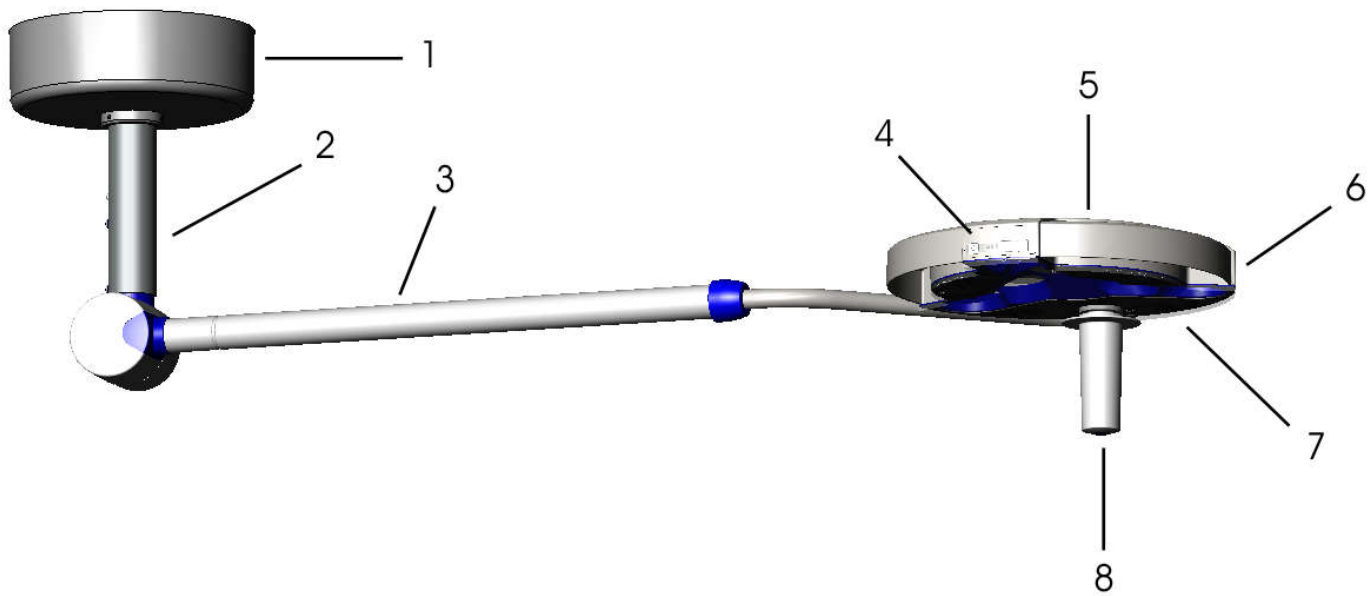

Fig. 3: Components of CHROMOPHARE® F 300 Ceiling, single arm

1	Soffit	5	Light head cover casing
2	Ceiling tube Ø 1.77 inch	6	Rail
3	Spring arm	7	Underglass
4	Control unit	8	Handle

3.1.3 CHROMOPHARE® F 300 Wall, double arm

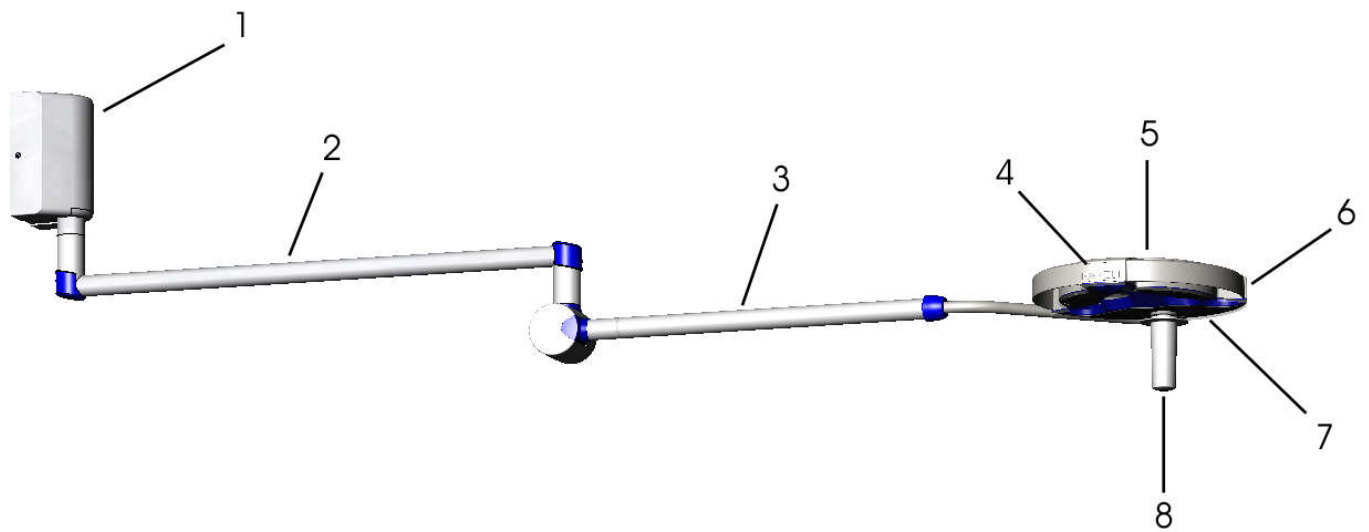

Fig. 4: Components of CHROMOPHARE® F 300 Wall, double arm

1	Wall bracket with power supply	5	Light head cover casing
2	Horizontal arm	6	Rail
3	Spring arm	7	Underglass
4	Control unit	8	Handle

Design and function

3.1.4 CHROMOPHARE® F 300 Wall, single arm

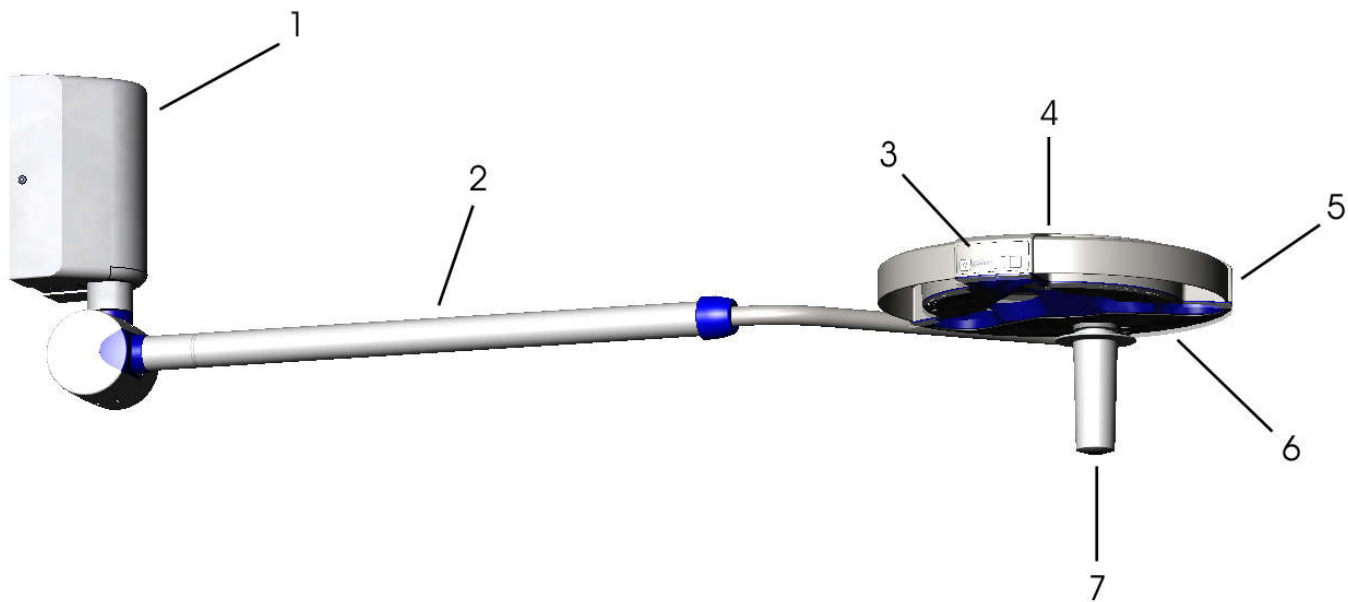

Fig. 5: Components of CHROMOPHARE® F 300 Wall, single arm

1	Wall bracket with power supply	5	Rail
2	Spring arm	6	Underglass
3	Control unit	7	Handle
4	Light head cover casing		

3.1.5 CHROMOPHARE® F 300 Mobile

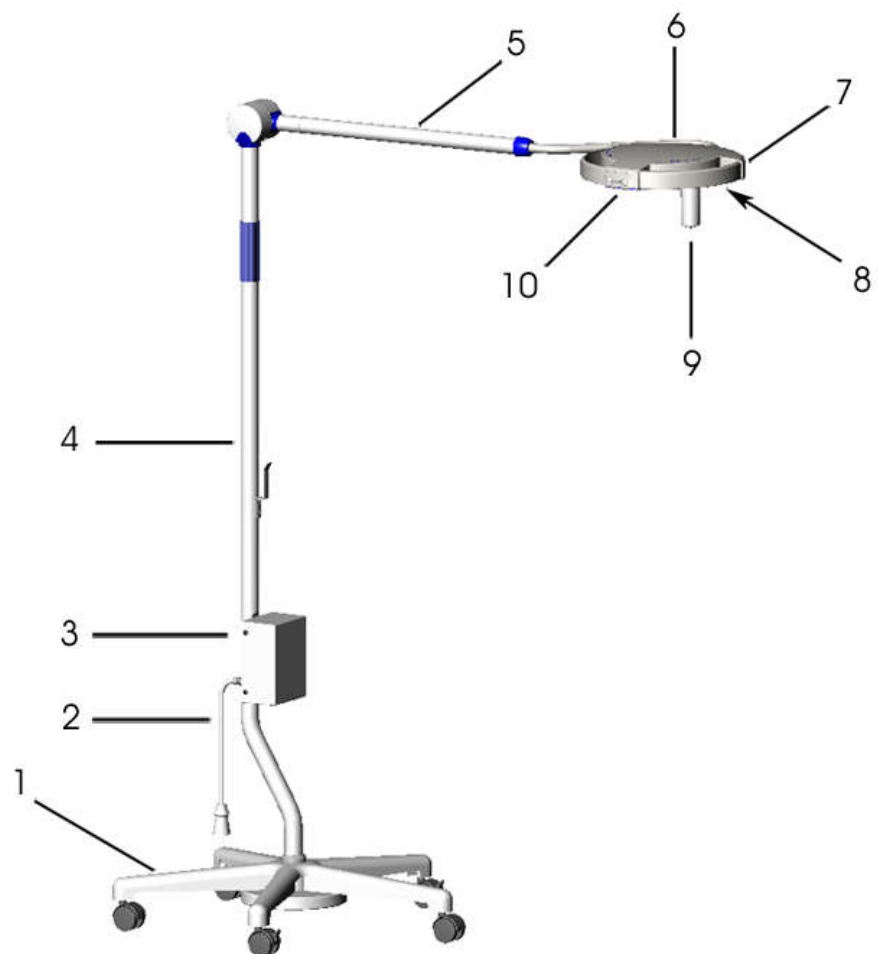

Fig. 6: Components of CHROMOPHARE® F 300 Mobile

1	Stand base	6	Light head cover casing
2	Power cable	7	Rail

Design and function

3	Housing with main supply fuse holder	8	Underglass
4	Tubular stand	9	Handle
5	Spring arm	10	Control unit

3.2 Short description

Suspension

The CHROMOPHARE® F 300 Ceiling examination light consists of

- a ceiling tube,
- a horizontal arm (where applicable) and
- a light head with spring arm

The light head is mounted on a bracket and can be turned, swivelled and tilted in any direction. Spatial repositioning of the light head is carried out using the 360° rotating horizontal arm. The height is adjusted using the spring arm.

The CHROMOPHARE® F 300 Wall examination light consists of

- a wall bracket,
- a horizontal arm (where applicable) and
- a light head with spring arm

The light head is mounted on a bracket and can be turned, swivelled and tilted in any direction. Spatial repositioning of the light head is carried out using the rotating horizontal arm. The height is adjusted using the spring arm.

The CHROMOPHARE® F 300 Mobile examination light consists of

- a mobile stand base
- a tubular stand and
- a light head with spring arm

The light head is mounted on a bracket and is rotatable by rotating the base of the stand. The height is adjusted using the spring arm.

Design and function

Light head	The light head is made of an impact-absorbing polymer material. It resists distortion and damage to painted surfaces.
Light properties	LEDs emulate the visible light spectrum, so infrared light and skin-irritating ultraviolet light are not emulated. This ensures cool light within the surgical field and the beam path of the surgical light. The special arrangement of the LED modules enables exceptionally good depth of illumination and low shading.
Control unit	There is a control unit on the light head rail. The membrane keypad is used to control the light features.
Hygiene	The strict hygiene requirements in the area of use are fulfilled by the suspension and by the replaceable sleeve with protective collar and integrated trigger mechanism.

3.3 System Variants

The CHROMOPHARE® F 300 examination light is available in the following variants:

- CHROMOPHARE® F 300 as ceiling light, single or double arm
- CHROMOPHARE® F 300 as wall light, single or double arm
- CHROMOPHARE® F 300 mobile

Design and function

3.4 Hazardous areas



Light exit hazardous area:

- Risk of dazzling due to high light intensity
- Danger of skin irritation in the event of light sensitivity

Hazardous area of complete light head, all moving arms:

- Risk of damage in the event of hard collision.

Fig. 7: Light exit hazard zone

3.5 Scope of delivery

Every CHROMOPHARE® F 300 is shipped with all individual components (e.g., suspension, horizontal arm, light head) preassembled.

In addition, the following accessories are supplied:

Quantity	Name	Item	Comment
1	Manual		as present, for all models
2	Replaceable sleeve with small encroachment protection	CZ 4990904	for all models

These consumables are available for additions and spare-parts procurement (Appendix).

Transport, packaging and storage

4 Transport, packaging and storage



NOTICE

Only the manufacturer's employees or authorized technicians may install and perform the initial start-up of the product.

However, users or maintenance personnel may be required to handle packages during installation and thereafter. The following instructions must be followed when performing such tasks.

4.1 Transport safety instructions

Unauthorized transport



CAUTION

Unauthorized transport can result in damage!

Transport by untrained personnel can result in expensive damage to the equipment.

✓ Therefore:

1. The unloading of packages during delivery and inner-company transport should be performed by trained personnel only.

4.2 Symbols on the packaging



Up

The tips of the arrows indicate the top of the package. They must always point up or contents could be damaged.

Transport, packaging and storage



Fragile

Identifies packages with fragile or sensitive contents. Handle the package with care, do not drop, and keep it from being bumped.

Tab. 1:

4.3 Transport inspection

Check the delivery immediately for completeness and any damage during transport.

For obvious transport damage, do the following:

- Do not accept the delivery, or accept it only conditionally.
- Note the extent of the damage on the shipping documents or on the transporter's delivery note.
- File a complaint.



NOTICE

Report every defect as soon as it is found. Claims for damages may be submitted only within the applicable claim period.

- To limit transport damage as far as possible, the original packaging must be used when returning a product to BERCHTOLD or a BERCHTOLD service centre. Provide the following information: Owner's name and address, serial number (see model plate), a description of the defect.

4.4 Packaging

Packaging notes

Packaging is commensurate with expected transport conditions. Only environmentally safe materials were used for packaging.

Transport, packaging and storage

The packaging is intended to protect individual components from transport damage, corrosion and other damage until installation is complete. Therefore, do not destroy the packaging and remove it only immediately prior to installation.

Working with packaging materials

Dispose of packaging materials in accordance with legal regulations and local ordinances.



CAUTION

Incorrect disposal presents an environment hazard

Packaging is made of valuable raw materials. In many cases, additional uses for the materials are possible, or they can be appropriately recycled for further use.

✓ Therefore:

1. Dispose of packaging in an environmentally safe manner.
2. Follow local disposal ordinances. If necessary, hire a professional disposal service.

4.5 Transport

Transporting pallets with a forklift

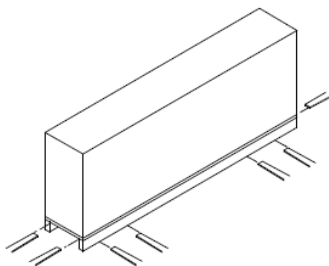

Fig. 8: Transport

Boxes on pallets can be moved using a forklift provided that:

- The construction of the forklift truck must be appropriate to the weight of the units for transport
- The driver must be authorised to drive the forklift truck.

Loading onto the forklift:

1. Drive the forklift truck forward, positioning the forks between or beneath the pallet rails.
2. Drive forward until the forks protrude from the opposite side.
3. If the centre of gravity is off-centre, make sure the pallet cannot tip over.

Transport, packaging and storage

4. Lift the pallet and begin transporting.

Storing packages

Observe the following conditions during transport and storage:

- Do not store outdoors.
- Keep dry and free of dust.
- Do not expose to corrosive media.
- Protect from sunlight.
- Avoid mechanical vibrations.
- Storage temperature: -4 to +158°F.
- Relative humidity: Relative humidity: max. 90%, no condensation.
- When storing for 15 weeks or longer, periodically check the general condition of all components and the packaging.



NOTICE

Certain boxes may be labeled with storage instructions that are more extensive than the requirements cited here. Follow them accordingly.

5 Installation and initial start-up

5.1 Safety

Human Resources

- Installation and initial start-up must only be carried out by specially trained expert staff.



WARNING

Improper installation and initial start-up can be hazardous!

Due to the heavy weight and high torque involved, only appropriately trained and experienced technicians may install and perform the initial start-up of the product.

Faults during installation may result in life-threatening situations or significant damage.

✓ Therefore:

1. Only employees of BERCHTOLD or their authorized representatives may install and perform the initial start-up of the product.
2. Electrical work is to be performed by skilled electricians only.
3. Consult BERCHTOLD even if the lighting is to be relocated.
4. Unauthorized installation and relocation are prohibited.

Personal protective equipment

The following protective equipment must be worn for all tasks related to installation and initial start-up:

- Protective helmet
- Safety boots



Protective helmet

Protects workers from any falling and projectile parts or materials.

Installation and initial start-up



Safety boots

Protect workers from any heavy falling parts and from slipping on slick surfaces.

Basic information



WARNING

Risk of injury with improper installation and initial start-up!

Improper installation and initial start-up can cause severe injury or damage.

✓ Therefore:

1. Before beginning installation, ensure there is adequate space.
2. Keep the installation site clean and organized. Components and tools lying around loose or atop one another are accidents waiting to happen.
3. Install components properly. Comply with the torque specified when tightening screws.

Electrical equipment



DANGER

Risk of electrocution!

Contact with live components can be life-threatening. Active electrical components can make uncontrolled movements and cause severe injuries.

✓ Therefore:

1. Before beginning work, switch off the electrical power and secure it against accidental switch-on.

5.2 Structural strength



NOTICE

Prior to the assembly of the CHROMOPHARE® surgical lights, qualified certification of the fulfilment of the structural requirements must be carried out.



DANGER

Danger from collapsing building parts if installation is not properly carried out!

Improper installation of the light may result in it working loose from the wall/ceiling mount and falling. This can cause life-threatening injuries for the patient and surgical staff.

✓ Therefore:

1. Heed the safety instructions.
2. Make sure that structural requirements are fulfilled.

The weights and moments are transferred to the supporting ceiling/wall via the ceiling/wall mount. Since the actual ceiling/wall loading in-situ depends on a variety of factors, a structural engineer must provide proof of stability for each particular case. When determining the necessary static load capacity of the ceiling/wall, it may be necessary to take additional loads on the ceiling/wall into account, as well as the required safety factor. The transfer of forces to the ceiling/wall must be secured. The load capacity of the ceiling/wall must be confirmed by a structural engineer. Moments and weights must never be exceeded. Adhere to the applicable regional building regulations. The construction design must be technically flawless. The anchorage types described in the next chapter refer to reinforced concrete ceilings/walls of an appropriate and professional standard according to DIN 1045. For other types of ceiling/wall, safe and viable ceiling/wall anchoring must be planned on site

Installation and initial start-up

5.3 Tools

For the installation of the CHROMOPHARE® examination lights, standard assembly tools will generally be required (including a hex key, screwdriver, spanner, hammer). If any special tools are required for installation, these are listed at the beginning of the instructions for that particular work step.

5.4 Bearing lubrication

All bearings are pre-mounted and fully lubricated prior to delivery. The bearing bushings do not need any additional lubrication. If the bearing bushings and connectors should require lubrication during installation, use a high-performance water-free lubricating paste based on a calcium-complex soap.

5.5 Ceiling CHROMOPHARE® F 300 Installation

5.5.1 Anchor plate with reinforcement plate

Basic information

Complete the installation of the anchor plate to the existing ceiling, using a reinforcement plate as described below.



NOTICE

A prerequisite to this is a ceiling thickness of at least 150 mm with a concrete strength class of at least B 25.

Special tool

- Drilling tool (hammer drill, core drill)

Installation steps

1. Measure the exact position of the light according to the plan requirements.
2. Mark four through holes. If needed use a template (Item No.).
3. Drill four boreholes Ø 17 mm using a suitable drilling tool.

Installation and initial start-up



DANGER

Risk of death through ceiling collapse if incorrect drilling weakens the ceiling

Incorrect drilling (e.g., drilling into a reinforcement bar) may jeopardise sufficient load capacity and load distribution in the building. This can lead to the collapse of building parts and cause serious personal injury.

✓ Therefore:

1. In case of incorrect drilling, immediately consult the structural engineer responsible.

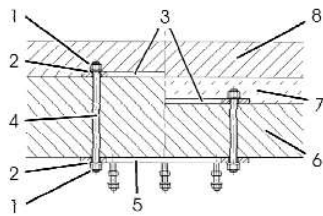

Fig. 9: Overview ceiling cut; left half without and right half with footfall sound insulation

1. Reinforcement plate (item 3) on the bare ceiling (item 6)
2. Insert threaded rods (item 4) together with the hexagonal nuts (item 1) and retaining washers (item 2) through the reinforcement plate and the bore-holes.
3. Position the anchor plate (item 5) on the threaded rods protruding down from the ceiling. Fasten using retaining washers (item 2) and hexagonal nuts (item 1). Then tighten the nuts to 180 Nm.
4. Then, have screed applied (item 8), if necessary with additional footfall sound insulation (item 7).

Installation and initial start-up



NOTICE

Reinforcement plate, threaded rods, washers, and hexagonal nuts are not included in the scope of delivery and must be supplied by the customer. The threaded rods must be of a screw strength class of at least 8.8, pursuant to DIN ISO 898 P1. The reinforcement plate can be purchased from BERCHTOLD (Dimensional drawings of ceiling anchor plates and spacer).

5.5.2 Anchor plate and spacer block with heavy-duty anchors

Basic information

Install the anchor plate on the reinforced concrete ceiling, preferably with a reinforcement plate. If this is not possible, heavy-duty anchors may be used for installation on concrete ceilings under specified conditions to be tested on a case-by-case basis. The following designs are valid for the Federal Republic of Germany. In other countries the relevant national regulations must be observed.

Installation and initial start-up



DANGER

Danger from collapsing building parts if installation is not properly carried out!

Use of inappropriate heavy-duty anchors can result in them working loose from the ceiling or breaking. The entire ceiling anchor can become loose and fall out. This can cause life-threatening injuries for the patient and surgical staff.

✓ Therefore:

1. Only use heavy-duty anchors that have building-inspectorate approval from the Building Research Institute (Berlin) for installation in the tension zone! Precise details regarding the planning and installation of fixtures using heavy-duty anchors, the permissible loads and the technical structural conditions are stated in the general structural engineering conditions. The certifications and specific mounting instructions are provided by the manufacturer of the heavy-duty anchor that is used.



NOTICE

To install the ceiling anchor plate using heavy-duty anchors, you must obtain an individual approval from the appropriate regional construction authorities.

5.5.2.1 Instructions for installing heavy-duty anchors/stud anchors

If installation with heavy-duty anchors is intended, a set of suitable heavy-duty anchors will be included in the delivery.

Installation and initial start-up



NOTICE

Do not use heavy-duty anchors from other manufacturers or with different specifications.

General structural engineering conditions

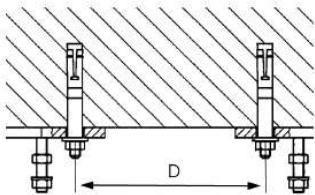

The heavy-duty anchors listed above can be used subject to the following structural requirements:

- Concrete strength class \geq B 25
- Ceiling thickness \geq 5,9 inch
- Edge distance D from the next ceiling opening \geq 5,9 inch

Fig. 10: Edge distance
Heavy-duty anchors used

Ceiling anchor plate	Pitch circle \emptyset	Drilled hole \emptyset	HILTI heavy-duty anchor
CB 5103304	10,62 inch	0,66 inch	HSL-G-TZ M10/20 (Type A)

Spacer	Pitch circle \emptyset	Drilled hole \emptyset	HILTI stud anchor
CB 1100104	10,62 inch	0,43 inch	HST M8/10 (Type B)

Dimensional drawing and dimensions

Type	d0	t	hs	l	Md	WAF	x
A	0,59	3,74	3,26	4,52	50	0,66	0,78
B	0,31	2,55	1,96	2,95	25	0,51	0,39

(All figures in inch, except Md: stated in Nm)

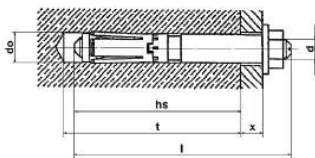

Abbreviation	Explanation	Abbreviation	Explanation
d0	Nominal drill-bit diameter	Md	Tightening torque
t	Minimum bore-hole depth	WAF	Width across flats
hs	Minimum embedding depth	x	Attachment height

Installation and initial start-up

Fig. 11: Dimensional drawing of heavy-duty anchors

Abbreviation	Explanation	Abbreviation	Explanation
l	Dowel length		

Steps for the installation of the heavy-duty anchor

When drilling the holes and setting heavy-duty anchors, always observe the following steps exactly. Note the specifications of the dimensional drawing and dimensions table.

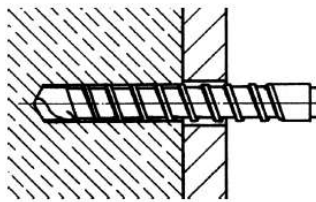

Fig. 12: Drill the hole

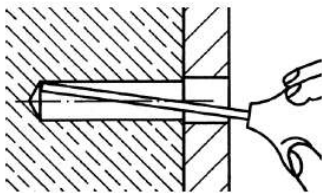

Fig. 13: Remove debris

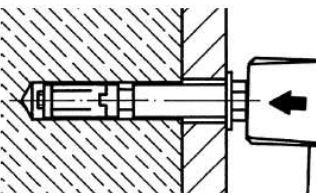

Fig. 14: Drive in the heavy-duty anchor

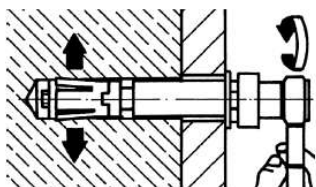

Fig. 15: Expand the heavy-duty anchor



1. Drill the hole

2. Remove drilling dust and cuttings from the hole using bellows.

3. Drive in the heavy-duty anchor with a hammer until flush.

4. Ensure that the minimum embedding depth, h_s , has been observed.

5. Expand the heavy-duty anchor using a torque wrench.

6. Ensure that the tightening torque, M_d , is observed. The heavy-duty anchor can be placed under load immediately.

7. After one hour retighten the heavy-duty anchor, applying the prescribed torque.

Installation and initial start-up

5.5.2.2 Steps for installing the ceiling anchor plate

Special tool

- Drilling tools (masonry drill, core drilling equipment)
- Bellows
- Torque wrench

Installation steps

1. Measure the precise position of the lights in accordance with the plan specifications and identify the position of one hole.
2. Drill the hole with a suitable drill and clean (Instructions for installing heavy-duty anchors/stud anchors).



DANGER

Risk of death through ceiling collapse if incorrect drilling weakens the ceiling

Incorrect drilling (e.g., drilling into a reinforcement bar) may jeopardise sufficient load capacity and load distribution in the building. This can lead to the collapse of building parts and cause serious personal injury.

✓ Therefore:

1. In case of incorrect drilling, immediately consult the structural engineer responsible.

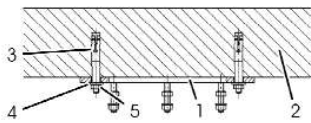

Fig. 16: Cross-sectional view of ceiling

1. Attach ceiling anchor plate (1) to the concrete ceiling (2). Affix the ceiling anchor plate to a heavy-duty anchor (3) using a retaining washer (4) and hexagonal nut (5).
2. Drill the remaining three boreholes. To do so, use the ceiling anchor plate as a drilling template.
3. Apply the remaining three heavy-duty anchors and affix as in step 3.
4. Screw all 4 hexagonal nuts tight with the prescribed tightening torque (Instructions for installing heavy-duty anchors).

Installation and initial start-up



NOTICE

Reinforcement plate, washers, and hexagonal nuts are not included in the scope of delivery and must be supplied by the customer. The reinforcement plate can be purchased from BERCHTOLD (Dimensional drawings of ceiling anchor plates and spacer).

5.6 Installing the spacer block

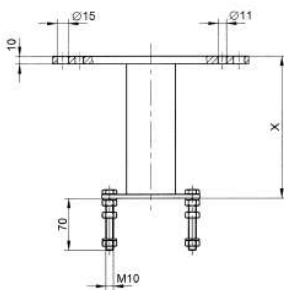

Fig. 17: Spacer block overview

A spacer block can be used to bridge large gaps (concrete ceiling / suspended ceiling). The spacer block can be obtained from BERCHTOLD (order numbers Section 11.2). The installation of the spacer block is carried out in the same way as the Ceiling CHROMOPHARE® F 300 Installation .

5.7 Installing a ceiling tube

Special tool

Installation and initial start-up

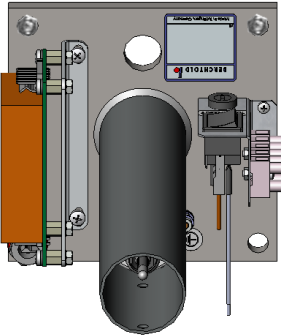

Fig. 18: Ceiling tube F 300

■ Spirit level

1. The ceiling tube of the light is equipped with 4 mounting holes (\varnothing 0,43 inch).
2. Align the ceiling tube vertically in the room using a level and the adjustment screws on the ceiling side.
3. Tighten fastening nuts a little at a time using a tightening torque of 34 Nm, making sure that the alignment of the ceiling tube is maintained.
4. Screw the fastening nuts with washers from step 1 onto the other three threaded bolts and tighten to a torque of 34 Nm.



NOTICE

Suspended ceilings require the use of a special soffit (Item No. CB 5392004). A spacer block between the bare ceiling and the suspended ceiling may also be necessary (order no. CB 1100104). When adapting a light to an existing anchor plate, a flange tube with a large flange plate is used (Item No. CB 5274004), see Section Ceiling CHROMOPHARE® F 300 Installation

5.8 Installing the soffit

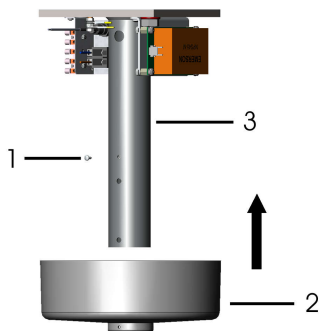
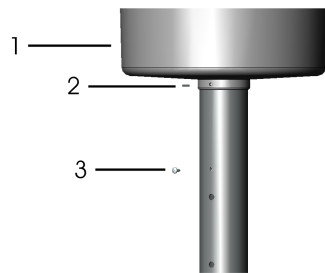

Fig. 19: Installing the soffit

After completion of installation and adjustments, cover the power supply and connecting terminals with the soffit.

1. Remove screw (1).
2. Slide the soffit (2) onto the ceiling tube (3).



1. Secure the soffit (1) with the grub screw (2).
2. Replace the previously removed screw (3).

Fig. 20: Secure soffit

5.9 Installation of horizontal arm (CHROMOPHARE® F 300 Ceiling, Double Arm) and spring arm (CHROMOPHARE® F 300 Ceiling, Single Arm)



CAUTION

Damage due to improper installation!

Plug contacts can be permanently damaged or destroyed if connectors and couplings are incorrectly paired.

✓ Therefore:

1. Make sure the connector/coupling pairs are correct.
2. Align the contacts on the connector and the socket before inserting the spring arm.

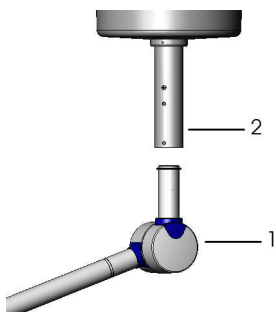

1. Push the horizontal arm/spring arm (1) into the ceiling tube (2).

Fig. 21: Installing the spring arm

Installation and initial start-up

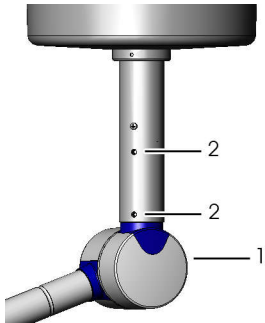

2. Secure the horizontal arm/spring arm (1) with the screws (2).

Fig. 22: Secure the spring arm

5.10 Attaching the spring arm to the horizontal arm ((CHROMOPHARE® F 300 Ceiling, Double Arm))



CAUTION

Damage due to improper installation!

Plug contacts can be permanently damaged or destroyed if connectors and couplings are incorrectly paired.

✓ Therefore:

1. Make sure the connector/coupling pairs are correct.
2. Align the contacts on the connector and the socket before inserting the spring arm.

Special tool

- Expanding pliers for the locking ring

Installation and initial start-up

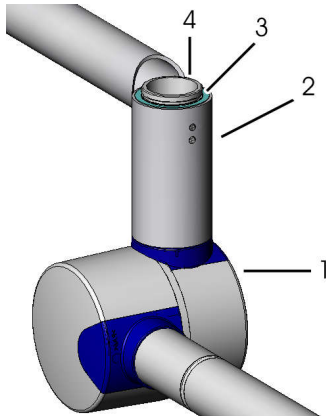

Fig. 23: Push the spring arm into the horizontal arm

1. Push the spring arm (1) into the horizontal arm (2).
2. Place the shim (2) on the shaft (4).



CAUTION

Material damage due to improper installation!

Overstretching can permanently damage the locking ring.

✓ Therefore:

1. Never overstretch the locking ring.
2. Always replace an accidentally overstretched locking ring with a new one.



Fig. 24: Fit the locking ring

1. Fit the locking ring (1) into the groove provided for it using expanding pliers. Check that the locking ring is fully seated in the groove.

Installation and initial start-up

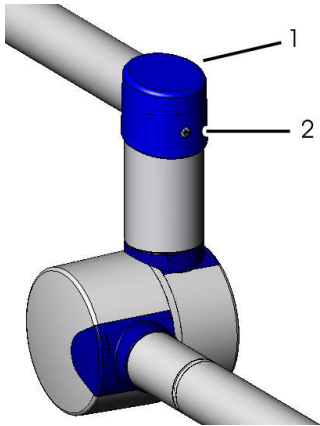

2. Attach the plug-in cap (1) and secure it with a screw (2).

Fig. 25: Attach cap with plug

5.11 Wall CHROMOPHARE® F 300 Installation

5.11.1 Installing the wall bracket



DANGER

Risk of death through wall collapse if incorrect drilling weakens the wall!

Incorrect drilling (e.g., drilling into a reinforcement bar) may jeopardize sufficient load capacity and load distribution in buildings. This can lead to the collapse of building parts and cause serious personal injury.

✓ Therefore:

1. In case of incorrect drilling, immediately consult the structural engineer responsible.

Installation and initial start-up



DANGER

Danger from collapsing building parts if installation is not properly carried out!

Use of inappropriate heavy-duty anchors can result in them working loose from the ceiling or breaking. The entire ceiling anchor can become loose and fall out. This can cause life-threatening injuries for the patient and surgical staff.

✓ Therefore:

1. Only use heavy-duty anchors that have building-inspectorate approval from the Building Research Institute (Berlin) for installation in the tension zone! Precise details regarding the planning and installation of fixtures using heavy-duty anchors, the permissible loads and the technical structural conditions are stated in the general structural engineering conditions. The certifications and specific mounting instructions are provided by the manufacturer of the heavy-duty anchor that is used.

The following designs are valid for the Federal Republic of Germany. In other countries the relevant national regulations must be observed.

Installation and initial start-up

5.11.1.1 Wall mount with heavy-duty anchor or stud anchors

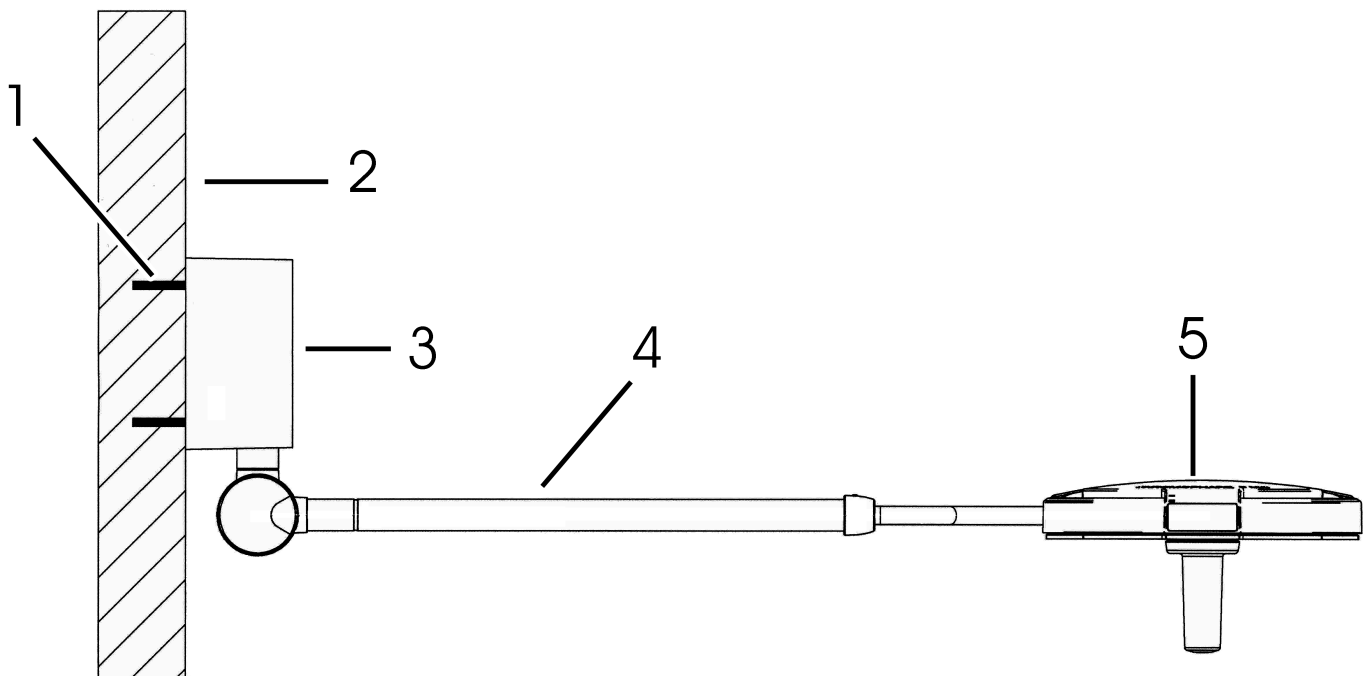

Fig. 26: Components wall mount with heavy-duty anchor or stud anchors

1	Heavy-duty anchor	4	Horizontal arm
2	Wall	5	Light head
3	Wall bracket with power supply		

5.11.1.2 Wall mount with reinforcement plate

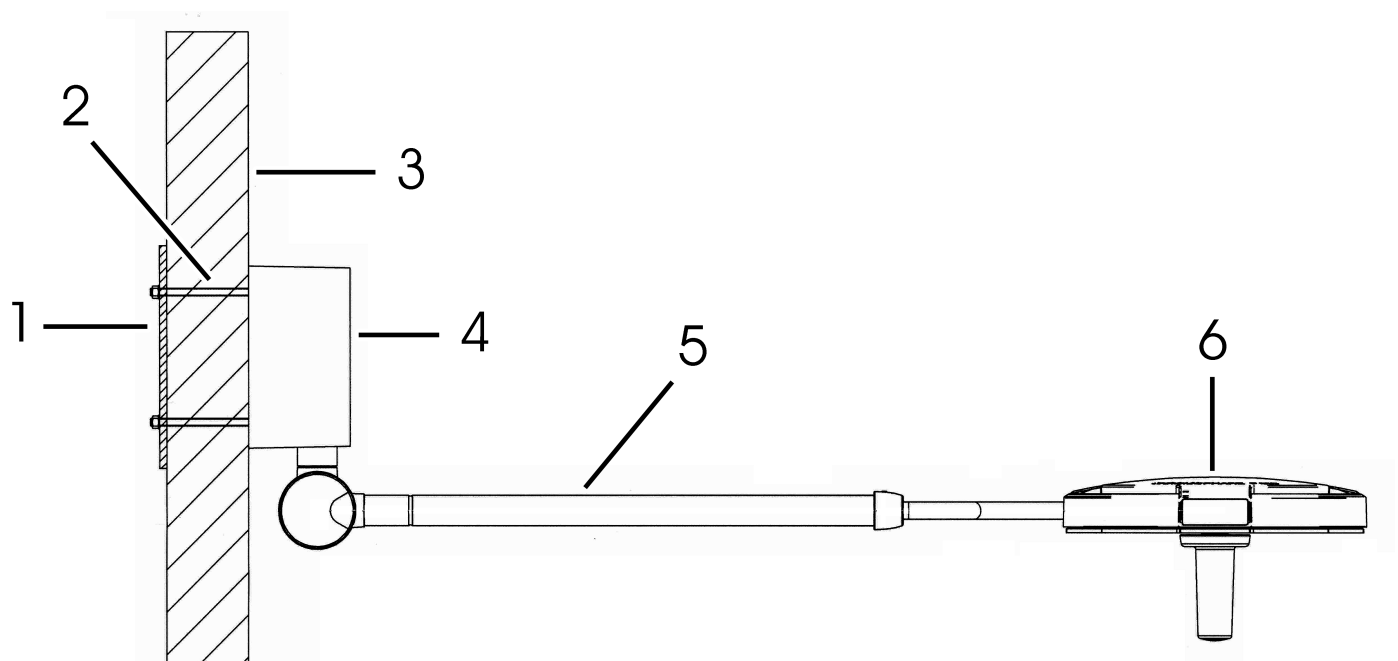

Fig. 27: Wall mount with reinforcement plate components

1	Reinforcement plate	4	Wall bracket with power supply
2	Threaded rods M8	5	Horizontal arm
3	Wall	6	Light head

Installation and initial start-up

5.11.1.3 Instructions for installation of heavy-duty anchors, stud anchors, threaded rods and bolt anchors with mesh sleeves



NOTICE

Installation of the wall bracket with a stud anchor, heavy-duty anchor or injection technology requires "individual approval" from the responsible regional building authority without exception!



CAUTION

Damage due to unsafe installation!

Inadequate installation of the wall mount can result in substantial material damage, since the wall bracket can fall out, thereby damaging the sub-floor and the mounting surface.

✓ Therefore:

1. The strength and stability of the mounting surface must be sufficient in terms of the total weight of the wall mount.
2. Securely install the wall mount using appropriate fixing materials for the nature of the mounting surface.



NOTICE

Do not use heavy-duty anchors from other manufacturers or with different specifications.

The wall bracket for the CHROMOPHARE® F300 wall can be secured with the following fixings:

Concrete wall type

Stud anchors Hilti HST M8/10

Heavy-duty anchors Hilti HST M8/10

Installation and initial start-up

Wall type honeycomb brick, hollow block, plasterboard walls, etc.

Threaded rods M8



NOTICE

A reinforcement plate or interior wall reinforcement is necessary!

Wall type honeycomb brick, hollow block, etc.

Bolt anchors with mesh sleeves



NOTICE

The anchor bolts must be stuck in using the Hilti HAT HY Injection system, for example!

Special tool

- Drilling tool (hammer drill, core drill)
- Bellows
- Torque wrench

General structural engineering conditions

The listed stud anchors can be used under the following structural conditions:

- Concrete strength class \geq B 25 is not valid for the wall!
- Wall thickness \geq 5,9 inch



NOTICE

Stud anchor, reinforcement plate, threaded rods, discs and hexagonal nuts are included in the scope of delivery and must be supplied by the customer. The threaded rods must at least meet the 8.8 bolt grade according to DIN ISO 898 T1.

Dimensional sheet and dimensions

Anchor type	d0	t	Md	hs
Stud anchors	0,31	2,55	25	3,11
Heavy-duty anchor	0,31	2,55	50	3,11

Installation and initial start-up

Threaded rods	0,31	depending on wall thickness	25	-
Bolt anchors with mesh sleeves	0,62	3,54	25	-

(all data in inch, except Md: data in Nm)

Legend:

Abbreviation	Explanation	Abbreviation	Explanation
d0	Drill hole diameter	Md	Tightening torque
t	Minimum borehole depth	hs	Minimum depth

Fixing steps for heavy-duty anchors, stud anchors or threaded rods

When drilling the holes and setting heavy-duty anchors, stud anchors or threaded rods, always observe the following steps exactly.

Observe specifications according to dimensional sheet and dimensional table.

1. Drill borehole

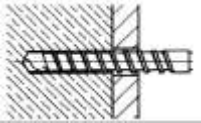

Fig. 28: Drill borehole

2. Remove drilling debris from the borehole using bellows.

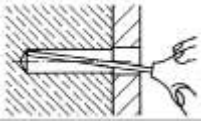

Fig. 29: Remove small parts

3. Install wall bracket with the necessary fixings (Section on wall bracket installation steps).

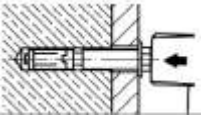

Fig. 30: Driving-in the heavy-duty anchor

4. Hammer in heavy-duty anchor until flush.

5. Make sure that the minimum depth of hs is complied with.

6. Expand heavy-duty anchor using the torque wrench.

7. Make sure that the tightening torque Md is complied with. The heavy-duty anchor can immediately be put under load.

8. After one hour, retighten the heavy-duty anchor to the specified tightening torque.

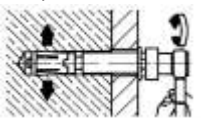

Installation and initial start-up

Fig. 31: Expand heavy-duty anchor

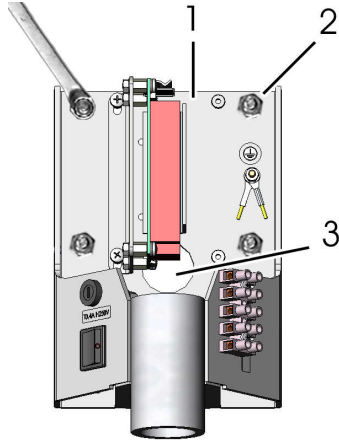

Wall bracket installation steps

The wall bracket is fastened to the wall with 4 plugs, see Section 6.11.

1. Fasten the wall bracket (1) to the wall using four M8 plugs (2) pursuant to Section Wall CHROMOPHARE® F 300 Installation.
2. Pass the power supply cable through the hole (3).

Fig. 32: Install wall bracket

5.12 Installation of horizontal arm (CHROMOPHARE® F 300 Wall, Double Arm) and spring arm (CHROMOPHARE® F 300 Wall, Single Arm)

Special tool

- Expanding pliers for the locking ring

1. Push the horizontal arm/spring arm (1) into the wall bracket (2).

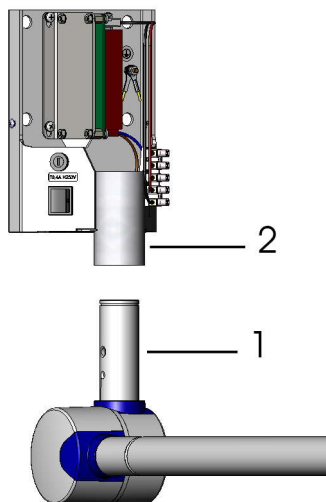

Fig. 33: Push the spring arm into the wall bracket

Installation and initial start-up

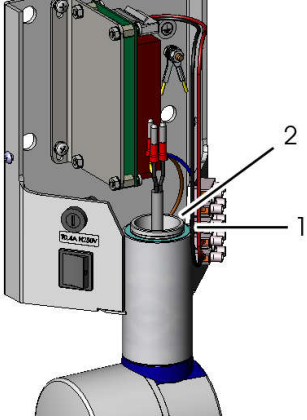

Fig. 34: Shim on the shaft

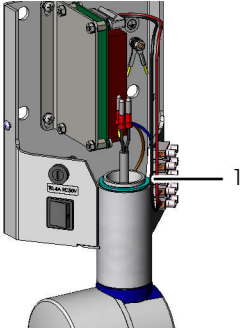

Fig. 35: Fit the locking ring

2. First place the shim (1) on the shaft (2).



CAUTION

Material damage due to improper installation!

Overstretching can permanently damage the locking ring.

✓ Therefore:

1. Never overstretch the locking ring.
2. Always replace an accidentally overstretched locking ring with a new one.

1. Fit the locking ring (1) into the groove provided for it using expanding pliers. Check that the locking ring is fully seated in the groove.

5.13 Installation of Spring Arm to the Horizontal Arm ((CHROMOPHARE® F 300 Wall, Double Arm)

Special tool

- Expanding pliers for the locking ring

Installation and initial start-up



CAUTION

Damage due to improper installation!

Plug contacts can be permanently damaged or destroyed if connectors and couplings are incorrectly paired.

✓ Therefore:

1. Make sure the connector/coupling pairs are correct.
2. Align the contacts on the connector and the socket before inserting the spring arm.

Special tool

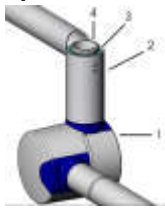

Fig. 36: Push the spring arm into the horizontal arm

1. Push the spring arm (1) into the horizontal arm (2).
2. Place the shim (2) on the shaft (4).



CAUTION

Material damage due to improper installation!

Overstretching can permanently damage the locking ring.

✓ Therefore:

1. Never overstretch the locking ring.
2. Always replace an accidentally overstretched locking ring with a new one.



Fig. 37: Fit the locking ring

1. Fit the locking ring (1) into the groove provided for it using expanding pliers. Check that the locking ring is fully seated in the groove.

Installation and initial start-up



Fig. 38: Attach cap with plug

2. Attach the plug-in cap (1) and secure it with a screw (2).

5.14 Installation of CHROMOPHARE® F 300 Mobile

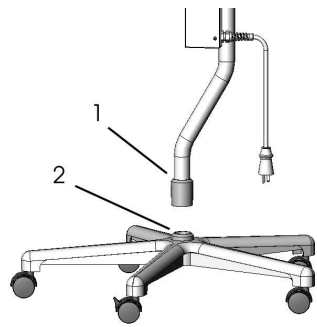

Fig. 39: Tubular stand in the base of the stand

1. Push the tubular stand (1) into the base of the stand (2).

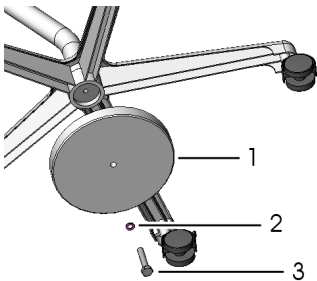

Fig. 40: Secure the tubular stand

2. Secure the tubular stand on the underside of the stand base with the disc (1), retaining washer (2) and screw (3).
3. After plugging in the power cable, the light is ready for use.

5.15 Mechanical adjustments

5.15.1 Diagrams

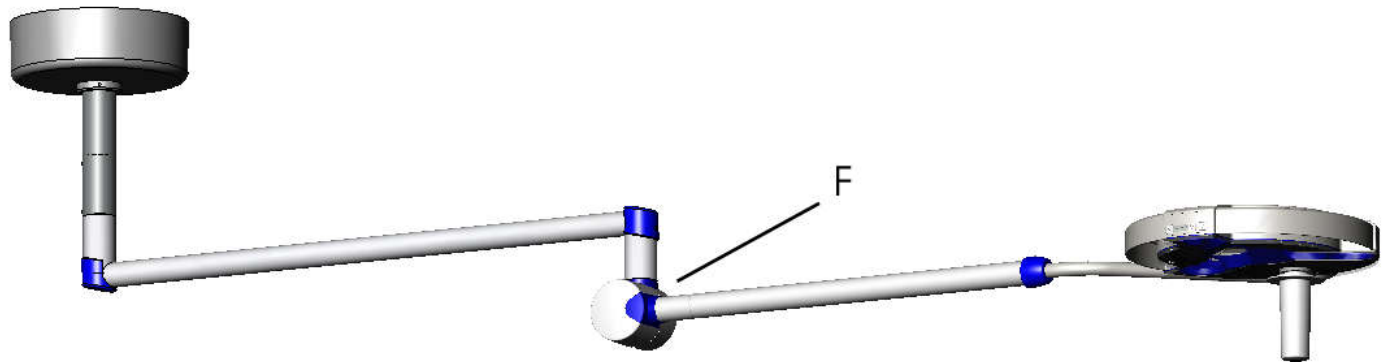

Fig. 41: Spring force setting, double arm

Installation and initial start-up

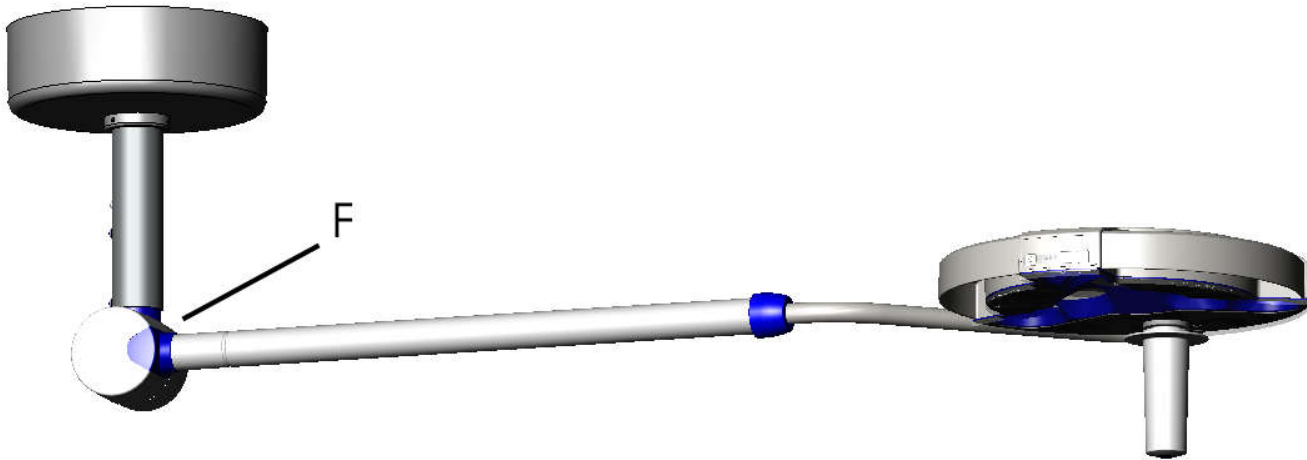
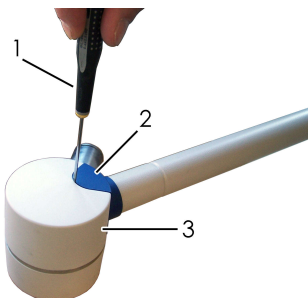

Fig. 42: Spring force setting, single arm

Abbreviation	Adjustment element
F	Spring tension adjustment

5.15.2 Fine-tuning the spring force in the spring arm



1. Carefully insert a thin slotted screwdriver (1) between the blue cover (2) and the spring arm cover (3).

Fig. 43: Loosen the blue cover

Installation and initial start-up

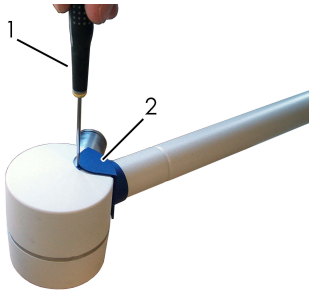

2. Turn the slotted screwdriver (1).
3. Slide the blue cover (2) upward.

Fig. 44: Remove the blue cover

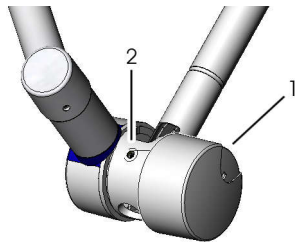

4. Remove the spring arm cover (1) from a side angle.
5. Use the slotted screwdriver to adjust the setting screw (2):
 - Rotating clockwise will increase the spring tension.
 - Rotating counterclockwise reduces the spring tension.
1. Slide cover (1) back into place.

Fig. 45: Adjustment screw F

5.16 Connecting the electricity



NOTICE

Electrical installation must be performed in accordance with European standard IEC 60364-710 as well as the currently valid national standards.

Power switches and fuses must be installed by the customer (fuses).

The supplied fuses and fuse holders must be used.

The cross section of the connection lines between fuses and transformers must be at least 1.5 mm².



NOTICE

Detailed circuit diagrams are available from Technical Support on request (address on inside back cover).

Installation and initial start-up



NOTICE

Pay attention to the fuse values on the fuse holders!



NOTICE

The fuses must be UL and IEC 60127 approved.

5.16.1 CHROMOPHARE® F 300 Ceiling

A.C. main power supply

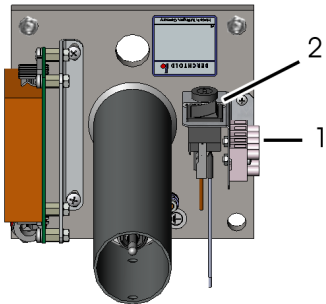

1. Attach mains supply L, N and PE (earth) cables to the to terminal strip (1).
2. To continue the mounting safely, turn main switch (2) to "OFF" position and only switch back to the "ON" position when mounting is complete.

Fig. 46: F 300 connectors

5.16.2 CHROMOPHARE® F 300 Wall

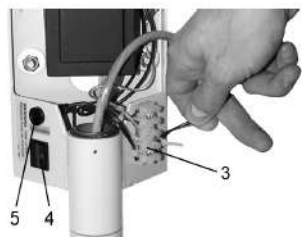

1. Attach the light leads to positions 1 and 2 on the connecting terminals (3).
2. Attach mains supply L, N and PE leads to the to connecting terminals (3).
3. To continue the mounting safely, disconnect the power at the main switch (4).
4. Secure the power supply using the fuse (5). For the fuse rating see the sticker below the fuse.

Fig. 47: Mains connectors

Installation and initial start-up

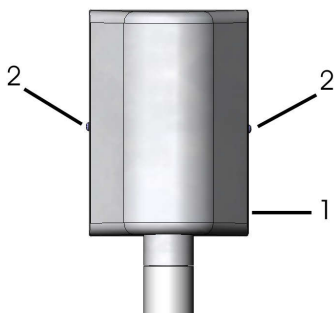

Fig. 48: Covering the wall bracket

5. Cover the wall bracket using the cover (1).
6. Secure the cover on both sides with screws (2).

5.17 Initial start-up

The operator must not commission the light until BERCHTOLD or the supplier engaged by BERCHTOLD

- has subjected the light to a functional test at the place of operation, and has instructed the person responsible for the operation of the light in the handling of the light based on the operating manual.

Appendix

6 Appendix

6.1 Consumables

Item	Item No.
Replacement sleeve with small encroachment protection (1 piece)	CZ 4990904

6.2 Dimensional drawings of ceiling anchor plates and spacer

6.2.1 Anchor Plate CHROMOPHARE® F 300 Ceiling

Item no. anchor plate	CB 5103304
Item No. reinforcement plate	

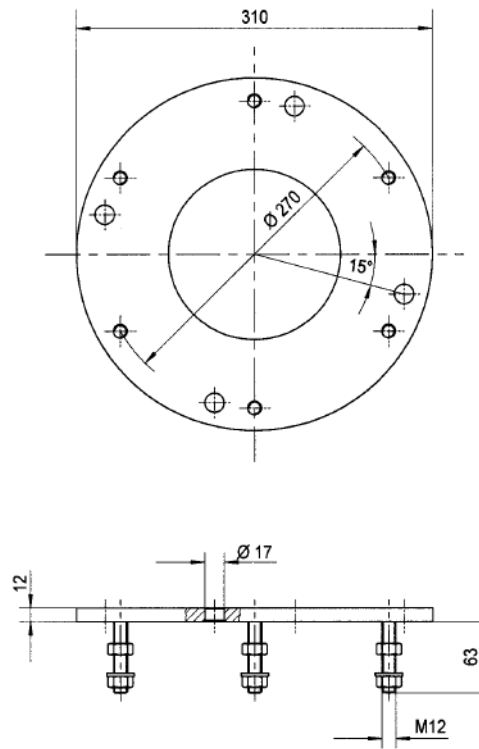

Fig. 49: Dimension sheet for anchor plate CG 5103304

Appendix

6.2.2 Wall Bracket for CHROMOPHARE® F 300 Wall

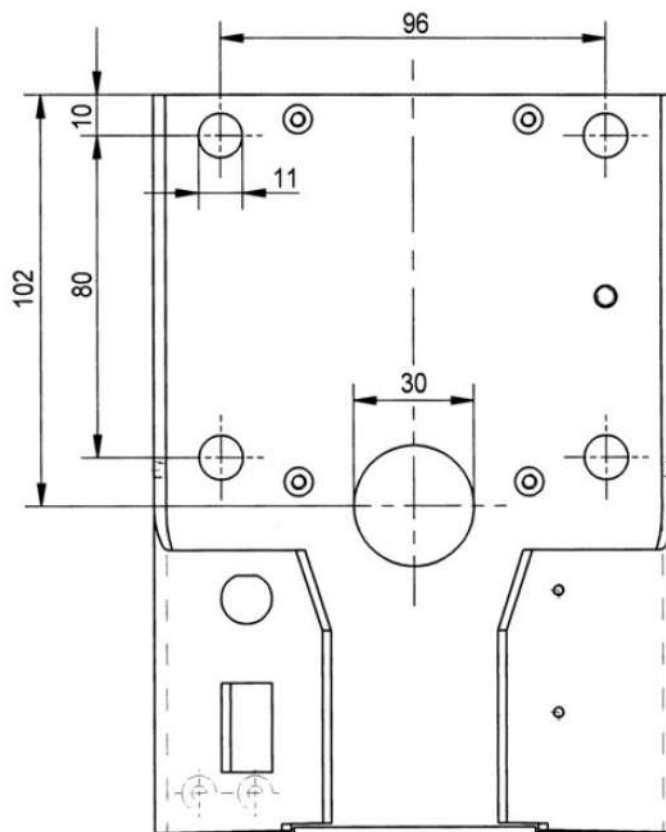

Fig. 50: Measuring sheet wall bracket

6.2.3 Spacer block

Item No. spacer block

CB 1100104 – up to 33,46 inch in length

CB 1100204 – up to 59,05 inch in length

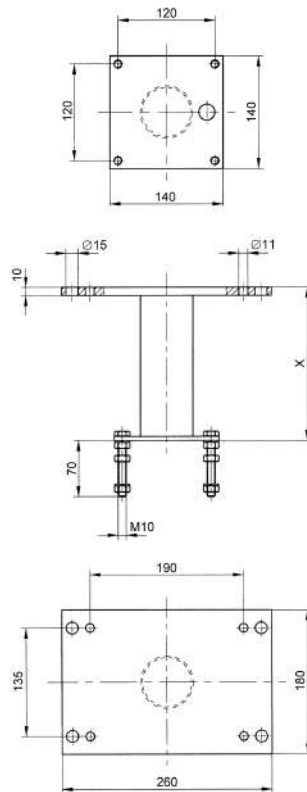

Fig. 51: Measuring sheet spacer block CB 1100104 and CB 1100204

6.3 Fuses, terminal voltages

6.3.1 Fuses

The following fuses must be provided on site (all fuses: inactive):

Appendix

Lights	100 – 240 V L, F1
F 300 ceiling	1.25 A
F 300 wall	
F 300 stand	



NOTICE

The fuses must be UL and IEC 60127 approved.

6.3.2 Terminal voltages

The connector tension listed in the following table must be noted at the ceiling tube of the

CHROMOPHARE® examination light(s):

Lights	AC
F 300 ceiling	100–120 V
F 300 ceiling	220–240 V

6.4 Information on electromagnetic compatibility (EMC)

Electrical medical devices such as this are subject to special EMC precautions and must be installed and put into operation in accordance with the instructions in the operating manual..

CHROMOPHARE® examination lights are intended for operation in the electromagnetic environments specified below. The operator of the lights must ensure that they are only used in such environments.

6.4.1 Guidelines and manufacturer's statement – electromagnetic emissions

Emissions test	Compliance	Electromagnetic environment – guidelines
RF emissions as per CISPR11	Class B	CHROMOPHARE® lights are intended for use in all facilities, including residential areas and those that are directly connected to a public power grid that also supplies buildings used for residential purposes.
Harmonic emissions as per IEC 61000-3-2	Class A	
Voltage fluctuations	Compliant	

6.4.2 Guidelines and manufacturer's statement – electromagnetic interference immunity

Immunity tests	IEC 60601 test level/ compliance level	Electromagnetic environment – guidelines
Electrostatic discharge (ESD) as per IEC 61000-4-2	≥ 6 kV Contact discharge ≥ 8 kV Air discharge	Synthetic floors should be antistatic and the relative humidity at least 30%.
Fast, transient electrical disturbances (bursts) as per IEC 61000-4-4	± 2 kV for mains cables ± 1 kV for input and output cables	The supply voltage quality should correspond to that of a typical commercial or hospital environment.
Surges as per IEC 61000-4-5	± 1 kV Differential-mode voltage ± 2 kV Common-mode voltage	The supply voltage quality should correspond to that of a typical commercial or hospital environment.

Appendix

Immunity tests	IEC 60601 test level/ compliance level	Electromagnetic environment – guidelines
Voltage drops, short inter- ruptions and fluctuations in the supply voltage as per IEC 61000-4-11 (UT: AC mains voltage prior to usage of the test level)	< 5 % UT t=10 ms (> 95 % drop)	The supply voltage quality should correspond to that of a typical commercial or hos- pital environment. In order to guarantee inter- ruption-free operation of the CHROMOPHARE® lights, the lights must also be connected to an emergency power sup- ply in accordance with DIN VDE 0100-710.
	40 % UT t=100 ms (60 % drop)	
	70% UT t=500 ms (30 % drop)	
	< 5 % UT t=5000 ms (> 95 % drop)	
Radiated RF fields per IEC 61000-4-3	3 V/m, 80 MHz to 2.5 GHz	For image distortion in lights with a built-in camera system, move the source of the elec- tric fields further away from the lights or install shielding.

A

A.C. main power supply	56
------------------------	----

C

Connected loads	12
Connector tensionn	62

D

Design	15
--------	----

E

Electrical current	9
Electromagnetic compatibility	62
EMC	62
EMC risks	9
Emissions	14
Environmental Protection	10

F

Fuses	61
-------	----

H

Hazardous areas	22
Hazards	8
Heavy-duty anchor	32

I

Initial start-up	57
Intended use	7

L

Lubricants	10
------------	----

M

Model plate	14
-------------	----

O

Operating conditions	13
Operator	5

P

Packaging	23, 24
Performance values	13
Personnel Requirements	6
Protective equipment	8
Installation	27
Protective goggles	8
Protective helmet	27

Q

Qualified electricians	6
------------------------	---

R

Reliability	8
-------------	---

S

Safety	5
Safety boots	27
Scope of delivery	22
Short description	20
Specialists	6
Staff	
Initial start-up	27
Installation	27
Storage	23, 26
Structural Analysis	29

Symbols

on the packaging	24
System variants	21

T

Technical data	11
Tools	30
Transport	23, 25
Forklift	25
Transport inspection	24

For over 90 years, BERCHTOLD has been a world leader in the design and manufacture of quality medical equipment. With our focus on improving patient outcomes, we deliver best in class products, experienced planning and project management and service with a personal touch. We measure our success by the quality of our customer and employee relationships.

Our products and services ...

- CHROMOPHARE® surgical and examination lights
- ChromoVision® video and camera systems
- ChromoView® monitor arms
- TELETOM® equipment management systems
- OPERON® surgical tables including a full range of accessories
- SUPERSUITE® custom surgical environments
- ByDesign™ surgical room design software
- Design, consulting, project management and customer support
- Factory trained service and installation support
- IntegraMount™ construction mounting solution

We invite your inquiry and the opportunity to assist in the planning, design and installation of your next clinical environment.



BERCHTOLD Corporation

1950 Hanahan Road
Charleston, SC 29406

Phone: 843-569-6100

Phone: 800-243-5135

Fax: 843-569-6133

Reprints, even of excerpts, prohibited.

We reserve the right to make changes in technology and design.