

VORTEX

A State-of-the-Art Human Waste Disposal Unit

A WORLD LEADER IN HOSPITAL HUMAN WASTE MANAGEMENT

The Vortex macerator is a unique and efficient system designed to deliver safe, clean and germ-free disposal of human waste.

The Vortex macerator delivers a superior solution to the human waste challenge in hospitals. Using only cold water and a simple mechanical action, in a non-dry maceration cycle, the Vortex disposes of Vernacare's molded pulp utensils in a safe and efficient manner.

The Vortex offers many superior benefits:

- Ease of use with "hands free opening" reducing cross contamination
- "One-Button" operation with an easy to read LCD indicator panel
- Innovative, sleek design ensures that surfaces are easy to wipe down and maintenance is quick and easy
- Automatic Cleaner/Deodorizer Dispenser automatically dispenses while running and is easy to refill
- Accessible front and side panels allows for easy maintenance
- Energy efficient with a less than 2 minute cycle that uses only cold water, saving both time and energy

Vortex Product Information Details

Item Number:	V40-300	V40-310
Electrical Requirements:	220 volts	110 volts
Cycle Time:	2 minutes	
Water Requirements:	Cold water only	

For more product specification information, visit www.vernacare.com

Vernacare products are biodegradable and made from 100% recycled post-consumer newsprint.



VORTEX

A State-of-the-Art Human Waste Disposal Unit



Vortex Product Dimensions

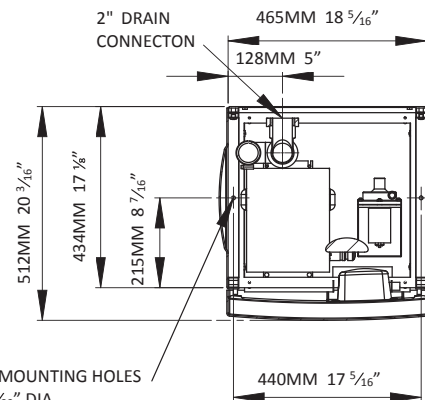
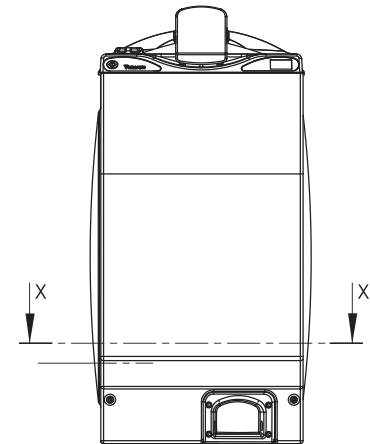
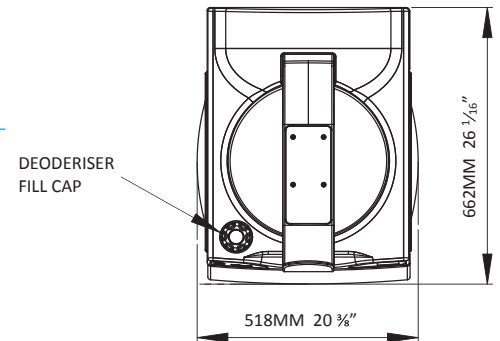
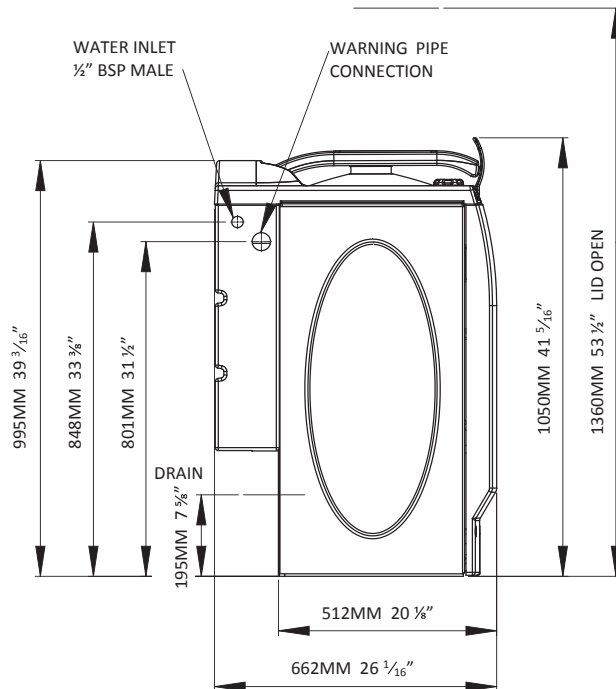

Installation Notes

1. Drain outlet terminates at a fitting suitable for a 2" dia. pipe stub.
2. Cold water supply: 1/2" flex braided line required, attaches to 1/2" BSP threaded float valve.
3. Electrical Supply: Connect to a 15 amp circuit.

Warranty: 1 Year, Parts Only.

For more product specification information, visit www.vernacare.com

CONTACT YOUR VERNACARE REPRESENTATIVE FOR MORE INFORMATION.

Vernacare Head Office
150 Norfinch Drive, Unit 4
Toronto, Ontario
Canada M3N 1X6

Toll Free: 1-800-268-2422
Toll Free Fax: 1-877-311-2811
Telephone: 416-661-5552
Fax: 416-661-5559

Email: marketing@vernacare.com
Website: www.vernacare.com

ENVIRONMENTAL PRINTING – IT'S MORE THAN RECYCLED PAPER.™

