

# **C** **MPACT**

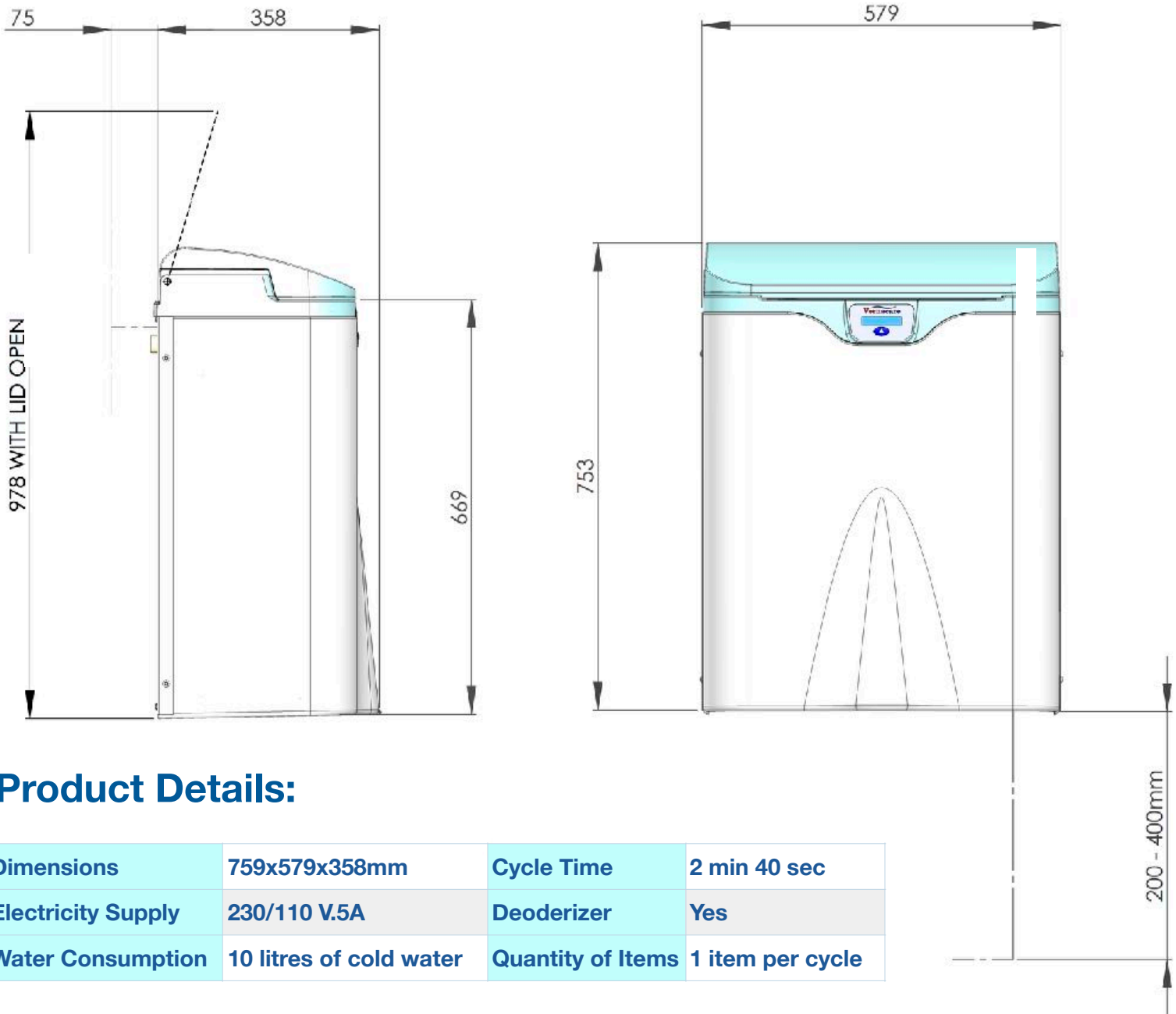

## **Technical Drawings & Installation Requirements (Metric)**

## Front of Unit



## Product Details:

Dimensions	759x579x358mm	Cycle Time	2 min 40 sec
Electricity Supply	230/110 V.5A	Deoderizer	Yes
Water Consumption	10 litres of cold water	Quantity of Items	1 item per cycle

## Back of Unit

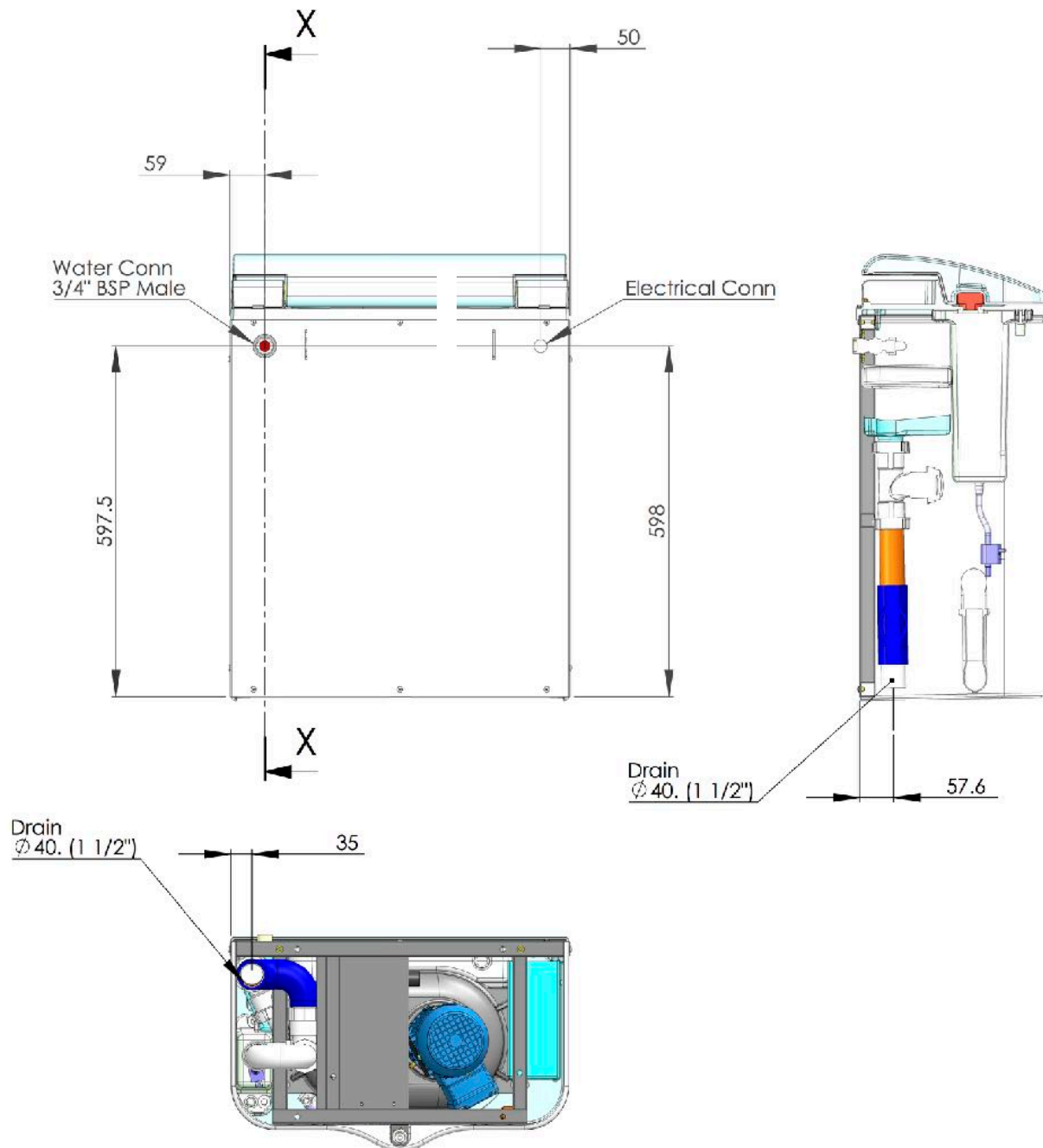

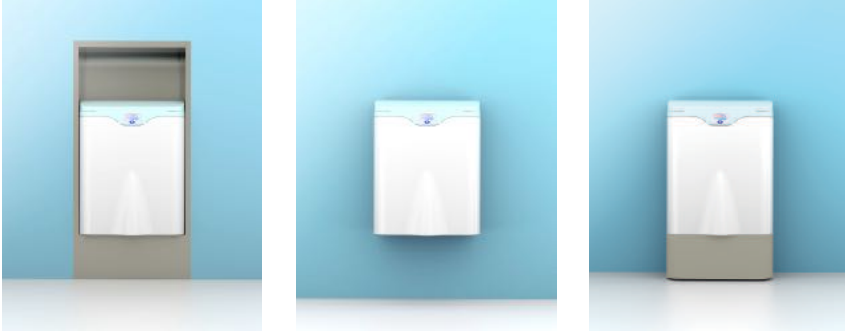

### Detail of Macerator Inset Assembly

Ref	Part Description
1	Frame Detail
2	Lower Front Panel
3	LH Side Panel
4	RH Side Panel
5	Back Cover Panel
6	Back Rubber Mounting Strip
7	Front Rubber Mounting Strip

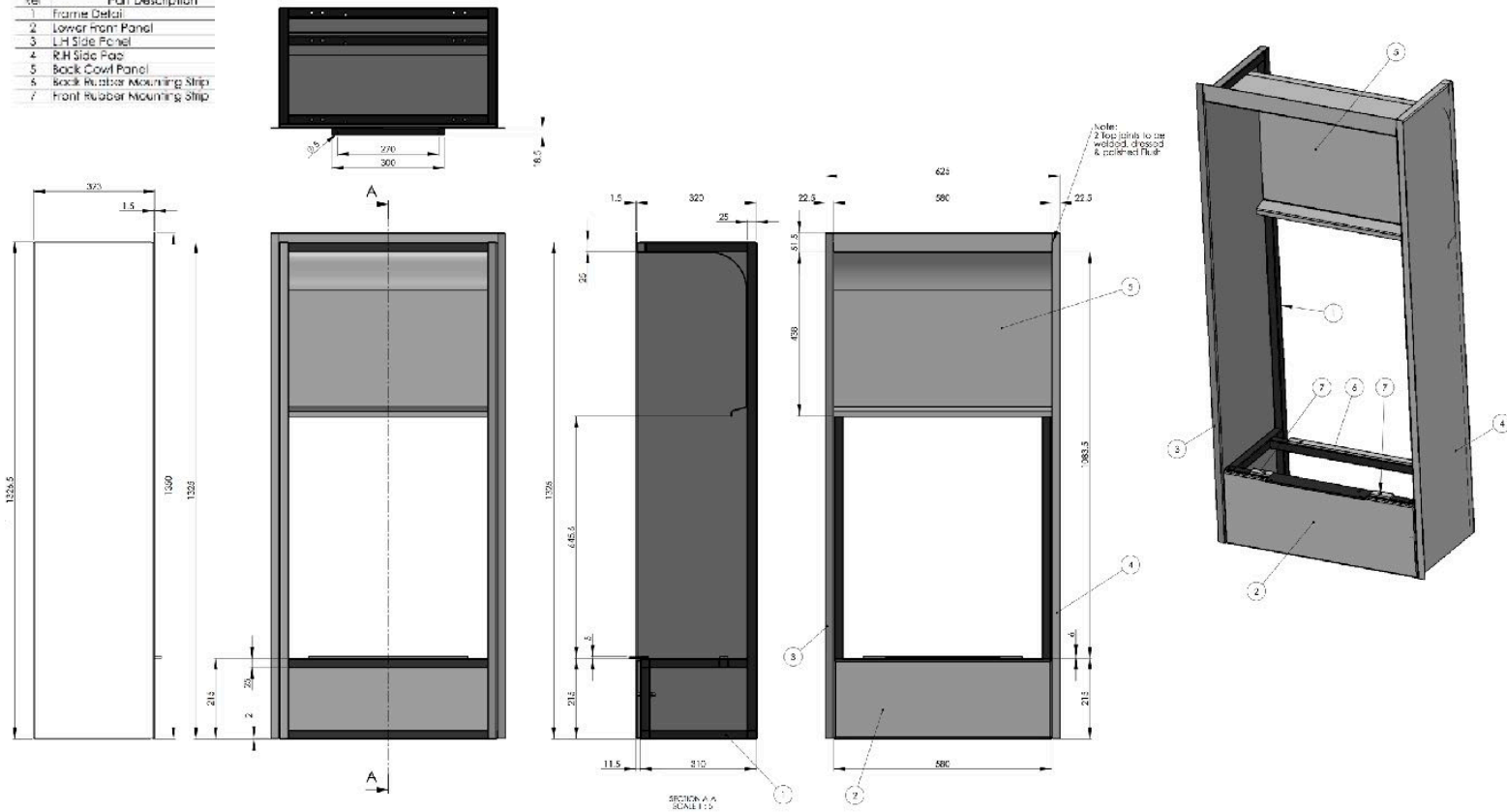

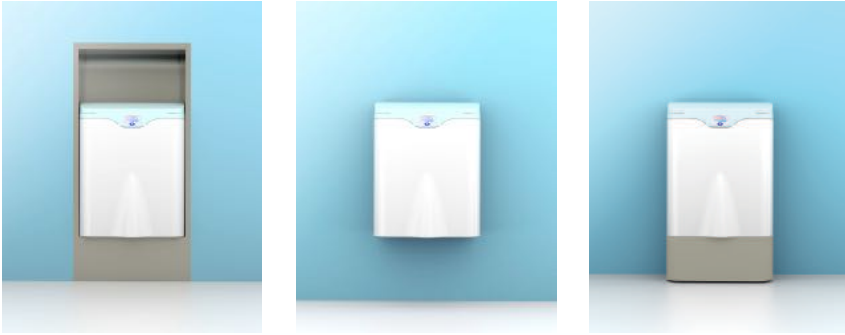

## Detail of Wall Bracket Stand Assembly

