

Protector® Laboratory Fume Hoods

HIGH PERFORMANCE, ENERGY SAVINGS



Protecting your
laboratory environment

LABCONCO®



Protector® XStream® Laboratory Hoods

The most energy efficient Labconco fume hood ever

The patented* Protector XStream Laboratory Hood was engineered to be the best containing fume hood. Testing shows the Protector XStream easily meets containment per SEFA-1† low velocity hood standards when subjected to the ASHRAE 110‡ test protocol with results of less than 0.05 ppm leak rate when tested at 4.0 lpm at OSHA-recognized 60 fpm face velocity.

During independent testing**, the Protector XStream Hood was challenged well beyond the SEFA-1† standards. With a face velocity of 40 fpm and sash fully open, the Protector XStream was subjected to 50 fpm cross drafts, NIH‡ protocol, and tracer gas measurements in the chest of the mannequin. In all scenarios, the Protector XStream allowed **0.00 ppm** average

level of tracer gas outside the fume hood. Although your safety officer or industrial hygienist will determine the actual face velocity setting for your laboratory, **the ability of the Protector Hood to contain under these adverse conditions sets a new standard of safety.**

Safety is foremost, but energy savings is equally impressive. Although face velocity is a factor, it's the **volumetric rate (CFM)** that determines the energy consumption of a fume hood. Operating a 6' Protector XStream Hood at 60 fpm face velocity, with the sash in its fully open position, requires only **690 CFM**. Regardless of your desired operating face velocity, the Protector XStream yields the **lowest required CFM**.

Energy savings translates to dollar savings. The Protector XStream Hood provides an excellent economic payback when compared to traditional by-pass hoods operated at 80 or 100 fpm. For example, a 6' Protector XStream Hood with sash fully open when operated at 60 fpm face velocity consumes a mere 690 CFM as previously mentioned. Compared to a traditional by-pass hood operated at 100 fpm (1250 CFM), the Protector XStream Hood offers significant savings, which adds up to annual dollar savings per year of \$3920.††

For even greater savings, the Protector XStream may be factory-prepared to accommodate a variable air volume system without the need for by-pass modifications.

Using the concepts of fluid dynamics, Labconco engineers designed the Protector XStream Laboratory Hood to produce **horizontal airflow, which reduces the tendencies for turbulence.** The innovative and aerodynamic designs of the sash

handle, air foil, upper dilution air supply and rear downflow baffle work in concert to produce horizontal airflow patterns that significantly reduce concentrations of chemical contaminants throughout the work area, particularly near the oper-

ator's breathing zone and at the work surface. Depending on sash position, tendencies for air turbulence, vortexing and **"the roll"** frequently observed during traditional fume hood smoke tests are virtually eliminated.

Traditional By-Pass Hood Design

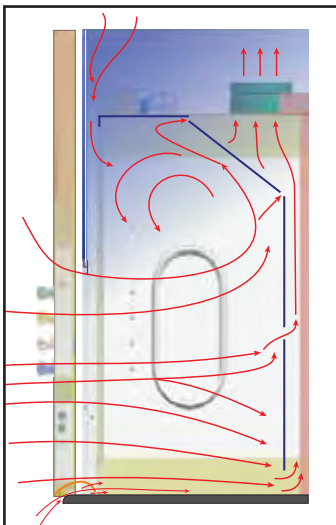

Smoke tests on traditional hoods show the tendency for contaminants generated in the interior to roll forward producing high concentrations of contaminants behind the sash in close proximity to the user's breathing zone.

Protector XStream Hood Design

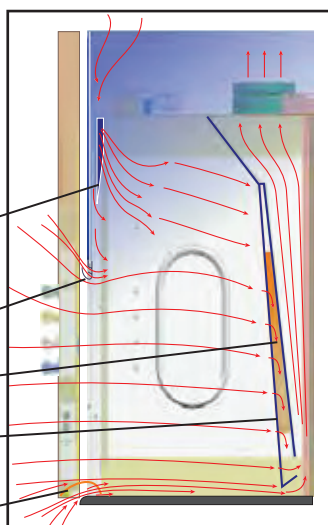

In contrast, smoke tests on Protector XStream Hoods show contaminants removed in a single pass and a remarkable lack of turbulence. Horizontal laminar air flowing toward the baffle forces contaminants to the rear interior, away from the user. The upper dilution air supply sweeps the upper interior to eliminate stagnant pockets of air and to prevent contaminants from concentrating behind the sash.

*U.S. Patent No. 6,461,233

**Independent testing by AccuTec Services, Inc., Lee's Summit, MO, National Environmental Balancing Bureau (NEBB)-Certified, Professional Engineer

†See back cover for a list of regulations, standards and registered trademarks.

††See page 5 for energy savings details.



Protector® XStream® Laboratory Hoods



Requires Ductwork and Blower

Upper Dilution Air Supply

The sash interior is constantly bathed with room air from the dilution supply above the work area to eliminate chemical fumes along the sash plane, near the critical breathing zone. A small percentage (5-10%) of the required air volume is introduced through the dilution air supply to ensure maximum containment.

No additional blowers are required.

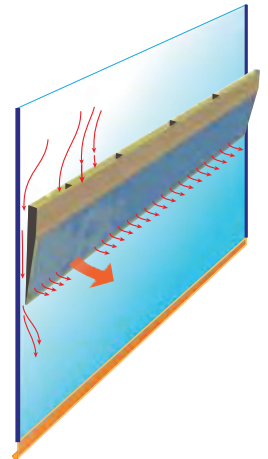

Rear Downflow Dual Baffle System

The slots in the primary baffle direct inflow air in non-turbulent streams from the hood face into the baffle in a single pass. The secondary baffle, located between the primary baffle and the back wall, counteracts the upward air streams that create roll in traditional hoods by forcing the air movement downward before exhausting.

No moving components are used.

The best containing Labconco fume hood ever

Clean-Sweep™ Sash Handle

The sash handle includes Clean-Sweep slots to bleed air into the hood chamber and direct chemical fume concentrations away from the user's breathing zone.

The slim-line radiused sash handle sweeps airflow into the hood with minimal turbulence.

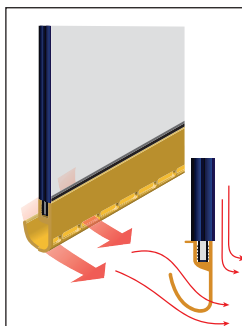

Opti-Zone™ Baffle

The Opti-Zone Baffle decreases the typical face velocity variations found with other baffles. The unique slot pattern and sizes increase velocities in the middle and at the work surface of the hood where it is needed while slowing velocities at the corners. This uniformity lowers the required average face velocity necessary for containment.

Tapered slots decrease resistance to air entering the baffle.

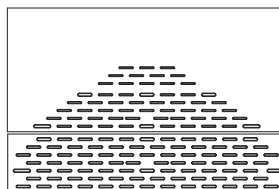

Eco-Foil™ Air Foil

The Eco-Foil reduces energy consumption by 7-10% compared to flat air foils while its aerodynamic curve allows air to sweep the work surface for maximum containment. Clean-Sweep openings pull inflow air from under the air foil forcing air into non-turbulent air streams. The curve is comfortable for arms resting on it while encouraging users to keep fume-generating items well within the hood's interior.

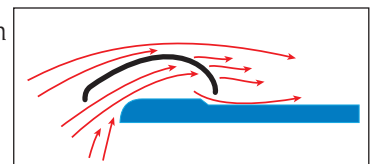



Protector® XStream® Laboratory Hoods

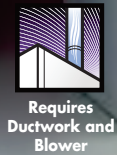

Requires
Ductwork and
Blower



5' Protector XStream Laboratory Hood 110510002 is shown with SpillStopper Work Surface 9503500, Protector Standard Storage Cabinet 9900200 and Protector Acid Storage Cabinet 9901200.

All models feature:

- By-pass airflow design with variable air volume compatibility.
- ☑ Eco-Foil Air Foil with aerodynamic Clean-Sweep™ airflow openings.*
- ☑ Cord-Keeper™ Slots on left and right side of air foil.
- ☑ Upper Dilution Air Supply.*
 - Glacier white powder-coated steel exterior.
- ☑ Rear Downflow Dual Baffle System.*
 - Chemical-resistant, fiberglass-reinforced, composite panel liner and baffles with flame spread index less than 25 per ASTM E84**. Baffles are removable for cleaning.
- ☑ Opti-Zone™ Baffle with tapered slots.
 - Tempered safety glass vertical-rising sash.
- ☑ Powder-coated sash handle with aerodynamic Clean-Sweep™ openings.*

*U.S. Patent No. 6,461,233

**See back cover for a list of regulations, standards and registered trademarks.

 Heights of switches, electrical receptacle and service fixtures meet requirements of Americans with Disabilities Act (ADA).

- 37.5" (95.3 cm) high sightline from the work surface to the header panel.
- ☑ Removable front and side panels, and front and interior service access panels for access to plumbing and electrical wiring.
- Pre-wired T8 fluorescent lighting with vapor-proof design and ADA-compliant light and blower switches.
- Sash stop located at 18" (45.7 cm) sash opening position.
- Powder-coated stainless steel, 12.81" (32.5 cm) ID exhaust connection(s).

All models conform to the following regulations and standards:**

- CFR 29, Part 1910
- SEFA 1-2010
- NFPA 45-2011
- ASTM E84-09C
- ASHRAE 110-1995
- ANSI Z9.5-2011
- UL 61010-1
- CAN/CSA C22.2 No. 61010-1
- UL 1805
- CE Conformity Marking (230 volt models)
- SEFA 8-2010, Cabinet Surface Finish Tests

Fixtured models feature:

- Two pre-plumbed service fixtures with forged brass valves, lower right side with brass tubing for gas and lower left side with copper tubing for cold water. Components for converting either or both fixtures to air and vacuum are provided. Inlet tubing is not provided.
- One pre-wired GFCI electrical duplex receptacle on lower right side and, on 8' models only, one additional pre-wired GFCI electrical duplex receptacle on the lower left side.

Required accessories not included:

- Remote Blower.
- Ductwork.
- Work Surface. See page 15.
- Base Cabinet or Stand.

Optional accessories for on-site installation include:

- Service Fixture Kits.
- Electrical Duplex Kits.
- Guardian Airflow Monitor Kits.
- Ceiling Enclosure and Rear Finish Panel Kits.
- Distillation Grid Kits.
- Sash Stop Kits.

Contact Labconco for ordering information on accessories.

 Exclusive Feature



Ordering Information, Airflow Data & Energy Savings

PROTECTOR® XSTREAM® LABORATORY HOODS

Use this key to configure the **nine digit catalog number** to order your Protector XStream Laboratory Hood. For example, a **110410002** is a 4' Protector XStream Laboratory Hood, with 100-115 volt, 50/60 Hz electrical requirements, two service fixtures and one GFCI electrical duplex receptacle.



STEP 1. Select the **width** of your fume hood. This number is the fourth digit of your catalog number. Shipping weight is also noted. Add 10 lbs. (5 kg) for Fixed Models.

- 4** = 4' (122 cm) **6** = 6' (183 cm)
- 440 lbs. (200 kg) 600 lbs. (272 kg)
- 5** = 5' (152 cm) **8** = 8' (244 cm)
- 525 lbs. (238 kg) 770 lbs. (349 kg)

STEP 2. Select the **Electrical Requirements, Service Fixtures** and **GFCI Electrical Duplex Receptacle** combination you desire. These two numbers comprise the eighth and ninth digits of your catalog number.

Electrical Requirements	No Service Fixtures	Two Service Fixtures	Two Service Fixtures & GFCI Duplex*
100-115 volts, 50/60 Hz, 10 amps	00	—	02
208-230 volts, 50/60 Hz, 5 amps	20	21	—

Total Exhaust CFM and Static Pressure @ 28" Sash Opening (100% Open)

Face Velocity (fpm)	Airflow Volumetric Rate (CFM) @ Static Pressure (inches of water)							
	4' Hood		5' Hood		6' Hood		8' Hood	
Sash @ Full Open (28")	CFM	s.p.	CFM	s.p.	CFM	s.p.	CFM	s.p.
100	705	0.26	930	0.32	1150	0.41	1600	0.29
80	565	0.17	745	0.20	920	0.26	1280	0.19
60	425	0.09	560	0.12	690	0.15	960	0.10

Total Exhaust CFM and Static Pressure @ 18" Sash Opening (62.5% Open)

Face Velocity (fpm)	Airflow Volumetric Rate (CFM) @ Static Pressure (inches of water)							
	4' Hood		5' Hood		6' Hood		8' Hood	
Sash @ 62.5% Open (18")	CFM	s.p.	CFM	s.p.	CFM	s.p.	CFM	s.p.
100	440	0.10	580	0.12	720	0.16	1000	0.11
80	350	0.06	465	0.08	575	0.10	800	0.07
60	265	0.04	350	0.05	430	0.06	600	0.04

The Protector XStream Laboratory Hood shows significant savings over its lifetime when compared to a typical fume hood. The CFM usage and related energy costs associated with exhausting tempered air from the laboratory to the outside are provided below. Maximum savings are achieved using a Protector XStream Laboratory Hood

operating at 60 fpm with a variable air volume system. Protector XStream Laboratory Hoods are compatible for use with variable air volume (VAV) systems. Please Contact Labconco for ordering information on factory preparing Protector XStream Laboratory Hoods to a specific VAV controller cutout.

Energy Savings Dollars Compared to a Typical Fume Hood

	CFM	Dollars/Year	Dollars/Lifetime [†]	Lifetime Dollar Savings Compared to Typical Hood
6' Typical Hood @ 100 fpm, full open sash (28"), constant volume	1250	\$8,750	\$131,250	0
6' XStream at 100 fpm, full open sash (28"), constant volume	1150	\$8,050	\$120,750	\$10,500
6' XStream at 60 fpm, full open sash (28"), constant volume	690	\$4,830	\$72,450	\$58,800
6' XStream at 60 fpm, 62.5% open sash (18"), constant volume	430	\$3,010	\$45,150	\$86,100
6' XStream at 60 fpm, variable air volume ^{††}	N/A	\$1,883	\$28,245	\$103,005

*Hoods with GFCI electrical duplex are rated at 20 amps. 8' hoods have two GFCI electrical duplex receptacles, one mounted on each side, rated at 20 amps each.

[†]Based on average annual dollars per CFM of \$7.00, fume hood operating 24 hours a day and 5 days per week (6240 hours per year). Average annual dollar per CFM range from \$5.00 to \$12.00 depending on geographic location. Lifetime calculations are based on 15 years.

^{††}Based on 8 hours per day with 18" sash opening and 60 fpm face velocity, and remaining time with sash closed. Closed sash air volume is based on ANSI Z9.5 minimum of 150 Air Changes per hour (ACH), and \$0.0000187/ft³ air.



Protector® Premier® Laboratory Hoods

Protector® Premier® Laboratory Hoods incorporate a sleek interior with a molded one-piece fiberglass liner, the signature feature of Labconco's leading line of fume hoods since 1961. The one-piece liner of specially-formulated, fiberglass-reinforced polyester offers corrosion and fire resistance and easy clean up. Without seams, the interior has fewer points of deterioration for longer life.

Like the Protector XStream Hoods, Protector Premier Hoods incorporate many containment-enhancing features including

Clean-Sweep™ technology and the Eco-Foil™ air foil. Testing confirms the Protector Premier Hood meets the SEFA-1* standard of a low velocity, high performance hood and may be operated as low as 60 fpm. These hoods are offered for use with a remotely-located blower or with a built-in blower — the only high performance hood with built-in blower available anywhere.

Features and benefits unique to Protector® Premier® Laboratory Hoods are described below. Additional features are detailed on page 8-11.



Requires
Ductwork and
Blower

One-piece molded fiberglass liner offers superior corrosion and chemical resistance, durability and light reflectivity. Its seamless and smooth, radiused corners make cleaning easy and results in less deterioration for longer life. On models for use with remote blowers, as shown above, the exhaust connections are also seamless, molded fiberglass.



Requires
Ductwork

Models with built-in blower are available. Built-in blower is belt-driven with molded thermoplastic housing and coated aluminum impeller that is non-sparking and corrosion-resistant. The blower is available with standard or explosion-proof motor.

*See back cover for a list of regulations, standards and registered trademarks.



Protector® Premier® Laboratory Hoods

FOR USE WITH REMOTE BLOWER



Requires Ductwork and Blower



4' Protector Premier Laboratory Hood 100400002 is shown with SpillStopper Work Surface 9500400 and Protector Standard Storage Cabinet 9900000.

All models feature:

- By-pass airflow design.
- Eco-Foil™ Air Foil with aerodynamic Clean-Sweep™ airflow openings.*
- Cord-Keeper™ Slots on left and right side of air foil.
- Glacier white powder-coated steel exterior.
- One-piece molded fiberglass liner and pre-set baffle(s) with flame spread less than 25 per ASTM E-84.**
- Tempered safety glass vertical-rising sash with powder-coated sash handle.
- 37.5" (95.3 cm) high sightline from the work surface to header panel.
- Removable front and side panels, and front service access panels for access to plumbing and electrical wiring.
- Pre-wired T8 fluorescent lighting with vapor-proof design and ADA-compliant light and blower switches.
- Molded fiberglass 12.81" ID exhaust connection(s).

All models conform to the following regulations and standards**:

- CFR 29, Part 1910
- NFPA 45-2011
- ASHRAE 110-1995
- UL 61010-1
- UL 1805
- SEFA 1-2010
- ASTM E84-09C
- ANSI Z9.5-2011
- CAN/CSA C22.2 No. 61010-1
- CE Conformity Marking (230 volt models)
- SEFA 8-2010, Cabinet Surface Finish Tests

Fixture models feature:

- Two pre-plumbed service fixtures with forged brass valves, lower right side with brass tubing for gas and lower left side with copper tubing for cold water. Components for converting either or both fixtures to air and vacuum are provided. Inlet tubing is not provided.
- One pre-wired GFCI electrical duplex receptacle on lower right side and, on 8' and larger models only, one additional pre-wired GFCI electrical duplex receptacle on the lower left side.

Required accessories not included:

- Remote Blower.
- Ductwork.
- Work Surface. See page 15.
- Base Cabinet or Stand.

Optional accessories for on-site installation include:

- Service Fixture Kits.
- Electrical Duplex Kits.
- Guardian Airflow Monitor Kits.
- Distillation Grid Kits.
- Sash Stop Kits.
- Ceiling Enclosure and Rear Finish Panel Kits.

Total Exhaust CFM and Static Pressure @ 28" Sash Opening (100% Open)

Face Velocity (fpm)	Airflow Volumetric Rate (CFM) @ Static Pressure (inches of water)							
	4' Hood		5' Hood		6' Hood		8' Hood	
Sash @ Full Open (28")	CFM	s.p.	CFM	s.p.	CFM	s.p.	CFM	s.p.
100	725	0.22	955	0.31	1180	0.41	1640	0.28
80	580	0.14	765	0.20	945	0.26	1310	0.18
60	435	0.08	575	0.11	710	0.15	985	0.10

Total Exhaust CFM and Static Pressure @ 18" Sash Opening (62.5% Open)

Face Velocity (fpm)	Airflow Volumetric Rate (CFM) @ Static Pressure (inches of water)							
	4' Hood		5' Hood		6' Hood		8' Hood	
Sash @ 62.5% Open (18")	CFM	s.p.	CFM	s.p.	CFM	s.p.	CFM	s.p.
100	450	0.09	595	0.12	735	0.16	1025	0.11
80	365	0.06	480	0.08	590	0.10	820	0.07
60	270	0.03	360	0.04	440	0.06	615	0.04

Contact Labconco for ordering information on accessories.

*U.S. Patent No. 6,461,233

**See back cover for a list of regulations, standards and registered trademarks.

♿ Heights of switches, electrical receptacle and service fixtures meet requirements of ADA.

Exclusive Feature



Ordering Information & Dimensional Data

PROTECTOR® PREMIER® LABORATORY HOODS FOR USE WITH REMOTE BLOWER

Use this key to configure the **nine digit catalog number** to order your Protector Premier Laboratory Hood. For example, a **100400002** is a 4' Protector Premier Laboratory Hood, with 100-115 volt, 50/60 Hz electrical requirements, two service fixtures and one GFCI electrical duplex receptacle.



STEP 1. Select the **width** of your fume hood. This number is the fourth digit of your catalog number. Shipping weight is also noted. Add 10 lbs. (5 kg) for Fixtured Models.

- 4** = 4' (122 cm) **6** = 6' (183 cm)
- 325 lbs. (147 kg) 485 lbs. (220 kg)
- 5** = 5' (152 cm) **8** = 8' (244 cm)
- 410 lbs. (186 kg) 650 lbs. (295 kg)

STEP 2. Select the **Electrical Requirements, Service Fixtures** and **GFCI Electrical Duplex Receptacle** combination you desire. These two numbers comprise the eighth and ninth digits of your catalog number.

Electrical Requirements	No Service Fixtures	Two Service Fixtures	Two Service Fixtures & GFCI Duplex*
100-115 volts, 50/60 Hz, 10 amps	00	—	02
208-230 volts, 50/60 Hz, 5 amps	20	21	—

*Hoods with GFCI electrical duplex are rated at 20 amps. 8' hoods have two GFCI electrical duplex receptacles, one mounted on each side, rated at 20 amps each.

TOP
8' Hoods

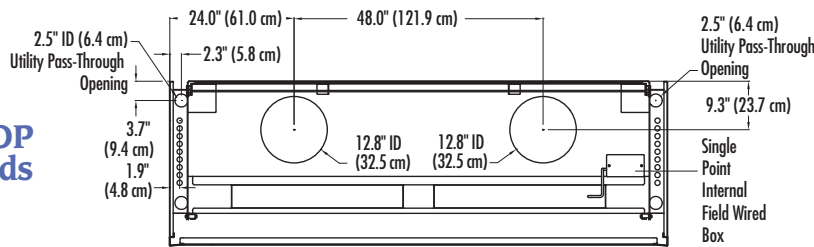

TOP
4', 5' & 6' Hoods

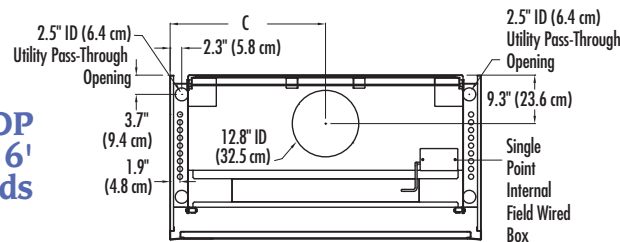

	A	B	C
4' Hood	48.0" (121.9 cm)	38.1" (96.8 cm)	24.0" (61.0 cm)
5' Hood	60.0" (152.4 cm)	50.1" (127.3 cm)	30.0" (76.2 cm)
6' Hood	72.0" (182.9 cm)	62.1" (157.7 cm)	36.0" (91.4 cm)
8' Hood	96.0" (243.8 cm)	86.1" (218.7 cm)	—

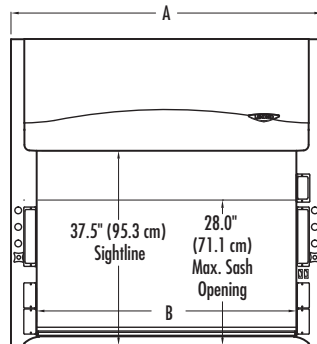

FRONT

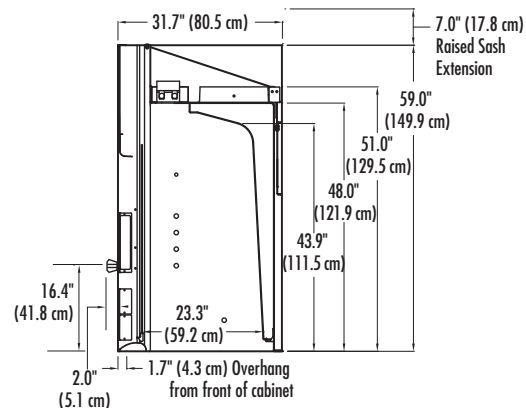

SIDE

Contact Labconco at 800-821-5525 or 816-333-8811 or visit www.labconco.com for BIM Revit® and detailed AutoCAD® drawings. See back cover for trademark information.



Protector® Premier® Laboratory Hoods

WITH BUILT-IN BLOWER



5' Protector Premier Laboratory Hood 100500042 is shown with SpillStopper Work Surface 9500500, Protector Standard Storage Cabinet 9900200 and Protector Acid Storage Cabinet 9901200.

All models feature:

- By-pass airflow design.
- Built-in belt-driven, corrosion-resistant exhaust blower with adjustable sheave, molded thermoplastic housing and non-sparking, coated aluminum impeller.
- ☑ Eco-Foil™ Air Foil with aerodynamic Clean-Sweep™ airflow openings.*
- ☑ Cord-Keeper™ Slots on left and right side of air foil.
 - Glacier white powder-coated steel exterior.
- ☑ One-piece molded fiberglass liner and pre-set baffle(s) with flame spread less than 25 per ASTM E-84.**
 - Tempered safety glass vertical-rising sash with powder-coated aluminum sash handle.
 - 37.5" (95.3 cm) high sightline from the work surface and header panel.
- ☑ Removable front and side panels, and front service access panels for access to plumbing and electrical wiring.
 - 10.8" ID exhaust connection (4' models); 12.8" ID exhaust connection (5' and 6' models).

All models conform to the following regulations and standards**:

- CFR 29, Part 1910
- NFPA 45-2011
- ASHRAE 110-1995
- UL 61010-1
- UL 1805
- SEFA 1-2010
- ASTM E84-09C
- ANSI Z9.5-2011
- CAN/CSA C22.2 No. 61010.1
- CE Conformity Marking (230 volt models)
- SEFA 8-2010, Cabinet Surface Finish Tests

Standard models feature:

- Pre-wired T8 fluorescent lighting with vapor-proof design, and ADA-compliant light and blower switches.

Explosion-proof models feature:

- Explosion-proof blower and incandescent light fixture (bulb not included).
- Furnished without switches, electrical receptacles and wiring.

Fixtured models feature:

- Two pre-plumbed service fixtures with forged brass valves, lower right side with brass tubing for gas and lower left side with copper tubing for cold water. Components for converting either or both fixtures to air and vacuum are provided. Inlet tubing is not provided.
- One pre-wired GFCI electrical duplex receptacle on lower right side.

Required Accessories not included:

- Ductwork.
- Work Surface. See page 15.
- Base Cabinet or Stand.

Optional accessories for on-site installation include:

- Service Fixture Kits.
- Electrical Duplex Kits.
- Guardian Airflow Monitor Kits.
- Distillation Grid Kits.
- Sash Stop Kits.
- Ceiling Enclosure and Rear Finish Panel Kits.

Built-in Blower Maximum External Static Pressure @ 100 fpm and with Sash Full Open (28")

Hood Width	CFM	S.P.	Nominal Ductwork Diameter	Equivalent Resistance†
4 Feet	725	0.17"	10"	75
5 Feet	955	0.12"	12"	75
6 Feet	1180	0.17"	12"	70

Contact Labconco for ordering information on accessories.

*U.S. Patent No. 6,461,233

**See back cover for a list of regulations, standards and registered trademarks.

†Equivalent resistance in feet of straight duct.

☑ Heights of switches, electrical receptacle and service fixtures meet requirements of ADA.

☑ Exclusive Feature



Ordering Information & Dimensional Data

PROTECTOR® PREMIER® LABORATORY HOODS WITH BUILT-IN BLOWER

Use this key to configure the **nine digit catalog number** to order your Protector Premier Laboratory Hood. For example, a **10060042** is a 6' Protector Premier Laboratory Hood with built-in blower, with 100-115 volt, 60 Hz electrical requirements, two service fixtures and one GFCI electrical duplex receptacle.



STEP 1. Select the **width** of your fume hood. This number is the fourth digit of your catalog number. Shipping weight is also noted. Add 10 lbs. (5 kg) for Fixtured Models. Add 10 lbs. (5 kg) for Explosion-Proof Models.

- 4** = 4' (122 cm) **6** = 6' (183 cm)
- 365 lbs. (166 kg) 525 lbs. (238 kg)
- 5** = 5' (152 cm)
- 450 lbs. (204 kg)

STEP 2. Select the **Electrical Requirements, Service Fixtures** and **GFCI Electrical Duplex Receptacle** combination you desire. These two numbers comprise the eighth and ninth digits of your catalog number.

Electrical Requirements	No Service Fixtures	Two Service Fixtures	Two Service Fixtures & GFCI Duplex*
100-115 volts, 60 Hz, 10 amps	40	—	42
208-230 volts, 50 Hz, 5 amps	50	51	—
208-230 volts, 60 Hz, 5 amps	60	61	—
100-115 volts, 60 Hz, 10 amps, explosion-proof blower	70	71	—

*Hoods with GFCI electrical duplex are rate at 20 amps. Centerline

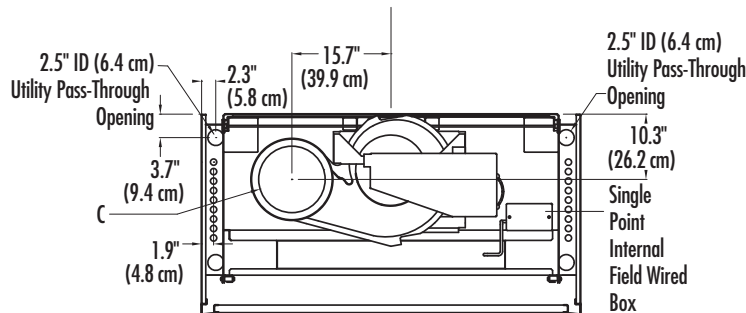

TOP

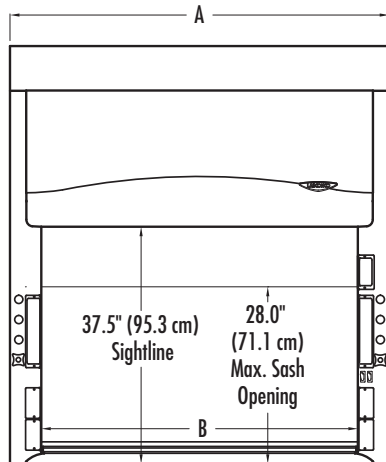

FRONT

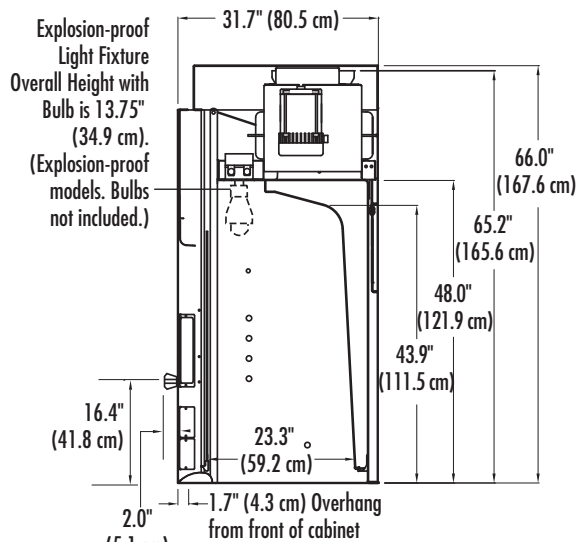

SIDE

	A	B	C
4' Hood	48.0" (121.9 cm)	38.1" (96.8 cm)	10.8" ID (27.5 cm)
5' Hood	60.0" (152.4 cm)	50.1" (127.3 cm)	12.8" ID (32.5 cm)
6' Hood	72.0" (182.9 cm)	62.1" (157.7 cm)	12.8" ID (32.5 cm)

Contact Labconco at 800-821-5525 or 816-333-8811 or visit www.labconco.com for detailed AutoCAD® drawings. See back cover for trademark information.



Protector® XL™ Laboratory Hoods

Protector XL Benchtop Laboratory Hoods have chemical-resistant panel liners that offer superior design flexibility. They are supplied in widths from 3 to 16 feet and three depths to meet a variety of installation and application requirements.

Like the Protector XStream Hoods, Protector XL Benchtop

Hoods incorporate many containment-enhancing features including Clean-Sweep™ technology and Eco-Foil™ air foil. Testing confirms the Protector XL Hood meets the SEFA-1* standard of a low velocity, high performance hood and may be operated as low as 60 fpm.



The Opti-Zone™ Baffle's unique slot pattern and sizes increase velocities in the middle and at the work surface of the hood where it is needed while slowing velocities at the corners. The overall effect is to lower the required average face velocity necessary for containment. Tapered slots decrease resistance to air entering the baffle.

**See back cover for a list of regulations, standards and registered trademarks.*



Protector[®] XL[™] Laboratory Hoods



Requires
Ductwork and
Blower



8' Protector XL Laboratory Hood 111800002 is shown with SpillStopper Work Surface 9500800, Protector Standard Storage Cabinet 9900000 and Protector Solvent Storage Cabinet 9902000.

All models feature:

- By-pass airflow design.
- ☑ Eco-Foil Air Foil with aerodynamic Clean-Sweep[™] airflow openings.*
- ☑ Cord-Keeper[™] Slots on left and right side of air foil.
 - Glacier white powder-coated steel exterior.
 - Chemical-resistant, fiberglass-reinforced, composite panel liner and baffle.
- ☑ Opti-Zone[™] Baffle* with flame spread index less than 25 per ASTM E84**. Baffle is removable for cleaning.
 - Tempered safety glass vertical-rising sash with powder-coated sash handle.
 - 37.5" (95.3 cm) high sightline from the work surface and header panel.
- ☑ Removable front and side panels, and front and interior service access panels for access to plumbing and electrical wiring.
 - Pre-wired T8 fluorescent lighting with vapor-proof design and ADA-compliant light and blower switches.
 - Powder-coated stainless steel, 12.81" (32.5 cm) ID exhaust connection(s).

All models conform to the following regulations and standards**:

- CFR 29, Part 1910
- SEFA 1-2010
- NFPA 45-2011
- ASTM E84-09C
- ASHRAE 110-1995
- ANSI Z9.5-2011



Exclusive Feature

- UL 61010-1
- CAN/CSA C22.2 No. 61010.1
- UL 1805
- SEFA 8-2010, Cabinet Surface Finish Tests

Fixtured models feature:

- Two pre-plumbed service fixtures with forged brass valves, lower right side with brass tubing for gas and lower left side with copper tubing for cold water. Components for converting either or both fixtures to air and vacuum are provided. Inlet tubing is not provided.
- One pre-wired GFCI electrical duplex receptacle on lower right side and, on 8' and larger models only, one additional pre-wired GFCI electrical duplex receptacle on the lower left side.

Required accessories not included:

- Remote Blower.
- Ductwork.
- Work Surface. See page 15.
- Base Cabinet or Stand.

Optional accessories for on-site installation include:

- Service Fixture Kits.
- Electrical Duplex Kits.
- Distillation Grid Kits.
- Sash Stop Kits.
- Guardian Airflow Monitor Kits.
- Ceiling Enclosure and Rear Finish Panel Kits.

Total Exhaust CFM and Static Pressure @ 28" Sash Opening (100% Open)

Face Velocity (fpm)	Airflow Volumetric Rate (CFM) @ Static Pressure (inches of water)											
	Sash @ Full Open (28")	3' Hood		4' Hood		5' Hood		6' Hood		7' Hood		8' Hood
	CFM	s.p.	CFM	s.p.	CFM	s.p.	CFM	s.p.	CFM	s.p.	CFM	s.p.
100	495	0.13	725	0.27	955	0.34	1180	0.46	1410	0.23	1640	0.31
80	395	0.08	580	0.17	765	0.22	945	0.29	1125	0.15	1310	0.20
60	295	0.05	435	0.10	575	0.12	710	0.17	845	0.08	985	0.11

Total Exhaust CFM and Static Pressure @ 18" Sash Opening (62.5% Open)

Face Velocity (fpm)	Airflow Volumetric Rate (CFM) @ Static Pressure (inches of water)											
	Sash @ 62.5% Open (18")	3' Hood		4' Hood		5' Hood		6' Hood		7' Hood		8' Hood
	CFM	s.p.	CFM	s.p.	CFM	s.p.	CFM	s.p.	CFM	s.p.	CFM	s.p.
100	310	0.05	450	0.11	595	0.13	735	0.18	880	0.09	1025	0.12
80	250	0.03	365	0.07	480	0.09	590	0.11	705	0.06	820	0.08
60	185	0.02	270	0.04	360	0.05	440	0.07	525	0.03	615	0.04

Contact Labconco for ordering information on accessories.

*U.S. Patent No. 6,461,233

**See back cover for a list of regulations, standards and registered trademarks.



Heights of switches, electrical receptacle and service fixtures meet requirements of ADA.



Ordering Information & Dimensional Data

PROTECTOR® XL™ LABORATORY HOODS

Use this key to configure the **nine digit catalog number** to order your Protector XL Laboratory Hood. For example, a **111800002** is an 8' Protector XL Laboratory Hood, with 31.7" depth, 100-115 volt, 50/60 Hz electrical requirements, two service fixtures and two GFCI electrical duplex receptacles.



STEP 1. Select the **width** of your fume hood. This number is the fourth digit of your catalog number. Shipping weight is also noted for 31.7" deep models. Add 10 lbs. (5 kg) for Fixtured Models.

3 = 3' (91 cm) 350 lbs. (159 kg)	5 = 5' (152 cm) 450 lbs. (204 kg)	7 = 7' (213 cm) 600 lbs. (272 kg)
4 = 4' (122 cm) 375 lbs. (170 kg)	6 = 6' (183 cm) 525 lbs. (238 kg)	8 = 8' (244 cm) 675 lbs. (306 kg)

STEP 2. Select the **exterior depth** of your fume hood. This number is the fifth digit of your catalog number. To the shipping weight noted above, add 40 lbs. (18 kg) for 37.7" deep models and 85 lbs. (39 kg) for 43.7" deep models.

0 = 31.7" (81 cm)	2 = 43.7" (111 cm)
1 = 37.7" (96 cm)	

STEP 3. Select the **Electrical Requirements, Service Fixtures and GFCI Electrical Duplex Receptacle** combination you desire. These two numbers comprise the eighth and ninth digits of your catalog number.

Electrical Requirements	No Service Fixtures	Two Service Fixtures	Two Service Fixtures & GFCI Duplex*
100-115 volts, 50/60 Hz, 10 amps	00	—	02
208-230 volts, 50/60 Hz, 5 amps	20	21	—

Contact Labconco for ordering information on Protector XL Laboratory Hoods wider than 8'.

*Hoods with GFCI electrical duplex are rated at 20 amps. 8' hoods have two GFCI electrical duplex receptacles, one mounted on each side, 20 amps each.

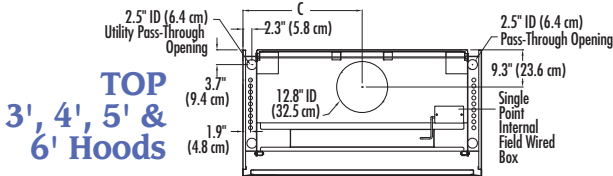
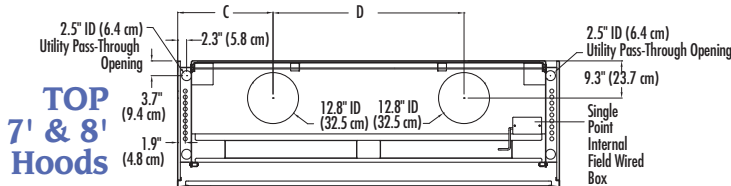

	A	B	C	D
3' Hood	36.0" (91.4 cm)	26.1" (66.3 cm)	18.0" (45.7 cm)	—
4' Hood	48.0" (121.9 cm)	38.1" (96.8 cm)	24.0" (61.0 cm)	—
5' Hood	60.0" (152.4 cm)	50.1" (127.3 cm)	30.0" (76.2 cm)	—
6' Hood	72.0" (182.9 cm)	62.1" (157.7 cm)	36.0" (91.4 cm)	—
7' Hood	84.0" (213.4 cm)	74.1" (188.2 cm)	21.0" (53.3 cm)	42.0" (106.7 cm)
8' Hood	96.0" (243.8 cm)	86.1" (218.7 cm)	24.0" (61.0 cm)	48.0" (121.9 cm)

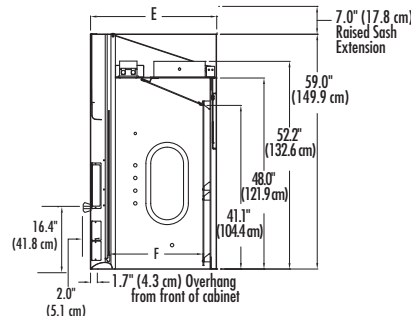
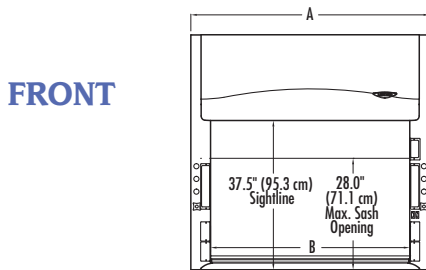

SIDE

E	F
31.7" (80.5 cm)	23.6" (59.9 cm)
37.7" (95.8 cm)	29.6" (75.2 cm)
43.7" (111.0 cm)	35.6" (90.4 cm)

Contact Labconco at 800-821-5525 or 816-333-8811 or visit www.labconco.com for BIM Revit® and detailed AutoCAD® drawings. See back cover for trademark information.



Ordering Information & Dimensional Data

SPILLSTOPPER™ WORK SURFACES

Use this key to configure the **seven digit catalog number** to order your SpillStopper Dished Solid Epoxy Work Surface. For example, a **9503610** is a 6' SpillStopper Work Surface, with a left rear cupsink cutout for use with a Protector XStream Hood.

9 5 0

STEP 1. Select the **model and exterior depth** of your fume hood. This number is the fourth digit of your catalog number.

Model & Depth	
0	Premier, XL with 31.7" depth
1	XL with 37.7" depth
2	XL with 43.7" depth
3	XStream, 37.7" depth

STEP 2. Select the **nominal width** of your fume hood. This number is the fifth digit of your catalog number.

3 = 3'	6 = 6'
4 = 4'	7 = 7'
5 = 5'	8 = 8'

STEP 3. Select a **left cupsink cutout** option (cupsink is sold separately). See dimensional drawing. This number is the sixth digit of your catalog number.

Left Cupsink Cutout	
0	None
1	Rear
2	Side**

STEP 4. Select a **right cupsink cutout** option (cupsink is sold separately). See dimensional drawing. This number is the seventh digit of your catalog number.

Right Cupsink Cutout	
0	None
1	Rear
2	Side**

*Protector XL Laboratory Hoods only.

**Not compatible with Protector Solvent Storage Cabinets.

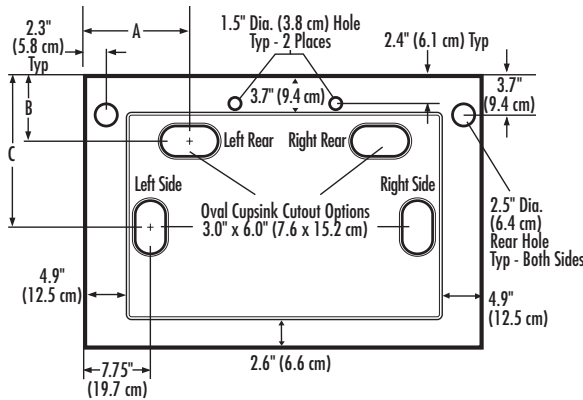

TOP

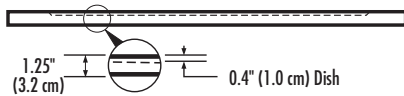

FRONT



SIDE



4005200 Oval Polypropylene Cupsink
Mounts in work surface with cupsink cutout, 3.0" x 6.0" (7.6 x 15.2 cm). 1.5" National Pipe Straight Mechanical (NPSM) thread. Shipping weight 4 lbs. (2 kg)

Hood Model/Depth	Work Surface Depth	A	B	C
Premier & XL, 31.7" deep	30.0" (76.2 cm)	9.5" (24.1 cm)	4.6" (11.7 cm)	18.8" (47.8 cm)
XL, 37.7" deep	36.0" (91.4 cm)	12.5" (31.8 cm)	7.3" (18.5 cm)	18.8" (37.8 cm)
XL, 43.7" deep	42.0" (106.7 cm)	12.5" (31.8 cm)	7.3" (18.5 cm)	14.9" (37.8 cm)
XStream, 37.7" deep	36.0" (91.4 cm)	12.5" (31.8 cm)	10.3" (26.2 cm)	18.8" (47.8 cm)

Nominal Width	Hood Model	Hood Exterior Depth	Hood & Work Surface Width	Work Surface Shipping Wt. lbs./kg
3'	XL	31.7"	36.0" (91.4 cm)	85/39
3'	XL	37.7"	36.0" (91.4 cm)	90/41
3'	XL	43.7"	36.0" (91.4 cm)	105/48
4'	Premier, XL	31.7"	48.0" (121.9 cm)	110/50
4'	XL, XStream	37.7"	48.0" (121.9 cm)	120/54
4'	XL	43.7"	48.0" (121.9 cm)	140/64
5'	Premier, XL	31.7"	60.0" (152.4 cm)	150/68
5'	XL, XStream	37.7"	60.0" (152.4 cm)	160/73
5'	XL	43.7"	60.0" (152.4 cm)	180/82
6'	Premier, XL	31.7"	72.0" (182.9 cm)	205/93
6'	XL, XStream	37.7"	72.0" (182.9 cm)	220/100
6'	XL	43.7"	72.0" (182.9 cm)	250/113
7'	XL	31.7"	84.0" (213.4 cm)	210/95
7'	XL	37.7"	84.0" (213.4 cm)	230/104
7'	XL	43.7"	84.0" (213.4 cm)	270/122
8'	Premier, XL	31.7"	96.0" (243.8 cm)	240/109
8'	XL, XStream	37.7"	96.0" (243.8 cm)	250/113
8'	XL	43.7"	96.0" (243.8 cm)	290/132



Standards & Registered Trademarks

Standards

Key aspects of standards and codes as they relate to laboratory ventilation are summarized below.

ASHRAE 110-1995 Method of Testing Performance of Laboratory Fume Hoods (ANSI Approved)

Evaluates fume hood's containment characteristics.

- Three part test: Smoke generation, face velocity profile, tracer gas release @ 4 liters per minute.
- Rated As Manufactured (AM), As Installed (AI) and As Used (AU).

American Society of Heating, Refrigerating and Air-Conditioning Engineers

1791 Tullie Circle NE
Atlanta, GA 30329
(404) 636-8400
www.ashrae.org

ANSI Z9.5-2011 Standard—Laboratory Ventilation

Covers entire laboratory ventilation system.

- Vertical stack discharge @ 2000-3000 fpm.
- New and remodeled hoods shall have a monitoring device.
- Ductless hoods should only be used with non-hazardous materials.

American Industrial Hygiene Association

2700 Prosperity Avenue, Suite 250
Fairfax, VA 22031
(703) 849-8888
www.aiha.org

Federal Register 29 CFR Part 1910

Occupational exposure to hazardous chemicals in laboratories

National Research Council Recommendations Concerning Chemical Hygiene in Laboratories (Non-mandatory) from "Prudent Practices."

- Fume hoods should have a continuous monitoring device.
- Face velocities should be between 60-100 linear feet per minute (lfpm).
- Average 2.5 linear feet of hood space per person.

Occupational Safety & Health Administration U.S. Department of Labor

200 Constitution Avenue, NW
Washington, DC 20210
(800) 321-6742
www.osha.gov

ASTM E84-09C Standard Test Method for Surface Burning Characteristics of Building Materials

Determines the relative burning behavior of the material by observing the flame spread along the specimen.

- Measures the flame spread and smoke development.
- Material is exposed to flaming fire for 10 minutes and the results measured and recorded.
- Results are compared to the indexes of mineral fiber cement board (flame spread and smoke development of zero) and red oak flooring (smoke development of 100).

ASTM International

100 Barr Harbor Drive
P.O. Box C700
West Conshohocken, PA 19428-2959
(610) 832-9585
www.astm.org

NFPA 45: Standard on Fire Protection for Laboratories Using Chemicals, 2011 edition

- Laboratory hoods should not be relied on for explosion protection.
- Fume hood exhaust air should not be recirculated.
- Services should be external to the hood.
- Materials of construction should have flame spread of 25 or less.

National Fire Protection Association

1 Batterymarch Park
Quincy, MA 02169-7471
(800) 344-3555 or (617) 770-3000
www.nfpa.org

NIH - Section 15991 Onsite Testing for Constant Volume Hoods - June 2006

- Follows ASHRAE test methods except for the following:
 1. 6 L tracer gas release rate instead of 4 L.
 2. Hood is loaded with boxes and cans.
 3. Rapid walk-by test.

National Institutes of Health

9000 Rockville Pike
Bethesda, MD 20892
(301) 496-4000
www.nih.gov

SEFA 1-2010 Laboratory Fume Hoods Recommended Practices

- High performance fume hood definition: hood with sash fully open and operating at 60 fpm contains at 4.0 AM 0.05
- Covers design, installation, testing, maintenance and safe use of laboratory fume hoods

SEFA 8-2010 Recommended Practices For Metal Laboratory Grade Furniture, Casework, Shelving and Tables, 8.0 Cabinet Surface Finish Tests

Defines test methods for evaluating the finish of laboratory furniture.

- Laboratory grade paint finishes shall withstand chemical exposure, hot water, and impact from a one-pound ball dropped from 12".
- Paint coating shall sufficiently adhere to the substrate.
- Paint shall be resistant to scratches.

Scientific Equipment & Furniture Association

1205 Franklin Avenue, Suite 320
Garden City, NY 11530
(516) 294-5424
www.sefalabs.com

UL 61010-1 Electrical Equipment for Laboratory Use

Specifies the general safety requirements for electrical equipment.

- Based on International Electrotechnical Commission (IEC) Publication 61010-1 with differences noted for U.S. use.
- Tests for protection against electrical shock, mechanical hazards, spread of fire, radiation, liberated gases, explosion and implosion.
- Tests for resistance to shock, vibration, impact, heat, moisture and liquids.

Underwriters Laboratories Inc.

333 Pfingsten Road
Northbrook, IL 60062-2096
(847) 272-8800
www.ul.com

CAN/CSA Standard C22.2 No. 1010.1 Safety Requirements for Electrical Equipment for Measurement, Control and Laboratory Use

Specifies general safety requirements for electrical equipment.

- Design and methods of construction should provide adequate protection to the operator and the surrounding area against shock or burn, mechanical hazards, excessive temperature, spread of fire from the equipment, gas liberation, explosion or implosion.

Canadian Standards Association

5060 Spectrum Way, Suite 100
Mississauga, Ontario
L4W 5N6, CANADA
(800) 463-6727 or (416) 747-4044
www.csa.ca

ETL listing

ETL Testing Laboratories is a Nationally Recognized Testing Laboratory (NRTL). The ETL mark signifies that a product conforms to the following:

- UL Standard 61010-1 in the U.S.
- CAN/CSA Standard C22.2 No. 61010.1 in Canada.
- Products that bear the ETL mark are subjected to a comprehensive safety program that includes testing, listing, labeling and quarterly follow-up inspections.

Intertek Group

www.intertek.com

CE Marking

Indicates an electrical apparatus conformity to all safety and other directives/specifications presently required by the Council of European Communities.

- Electrical safety.
- Electromagnetic emissions testing — interference signals being output by the product.
- Electromagnetic immunity testing — the product does not respond to outside electromagnetic interference signals.

European Union

www.europa.eu

Registered Trademarks

AutoCAD® is a registered trademark of Autodesk.

ANSI® is a registered trademark of American National Standards Institute.

Revit® is a registered trademark of Autodesk.

SEFA® is a registered trademark of Scientific Equipment and Furniture Association.

UL® is a registered trademark of UL, LLC.



Protecting your laboratory environment

LABCONCO®

Labconco Corporation

8811 Prospect Avenue, Kansas City, MO 64132-2696
800-821-5525 or 816-333-8811
FAX 816-363-0130, www.labconco.com

