



Product Equipment Specifications

67-2031 Rev-AR



About Omnicell

Omnicell, Inc. (NASDAQ: OMCL) is a leading provider of systems and software solutions targeting patient safety and operational efficiency in healthcare facilities. Since 1992, Omnicell has worked with numerous healthcare facilities to enhance patient safety and allow clinicians to spend more time with their patients.

Omnicell's medication-use product line includes solutions for the central pharmacy, nursing unit, operating room, and patient bedside. Solutions range from large central pharmacy "smart inventory" carousels to small handheld devices. From the point at which a medication arrives at the receiving dock to the time it is administered, Omnicell systems store it, package it, bar code it, order it, issue it, and provide information and controls on its use and reorder.

Our supply product lines provide a healthcare institution with fast, effective control of costs, capture of charges for payor reimbursement, and timely reorder of supplies. Products range from high-security closed-cabinet systems and software to open-shelf and combination solutions in the nursing unit, cath lab, and operating room.

Omnicell's mission is to provide the best customer experience in healthcare, helping hospitals reduce medication errors, operate more efficiently, and decrease costs. For more information, visit www.omnicell.com.

This guide and accompanying software and/or hardware described in it are protected under copyright laws and may not be copied, wholly or in part, without the express written consent of Omnicell, Inc. The same proprietary and copyright notices must be attached to any permitted copies as were attached to the original documents.

590 E. Middlefield Road
Mountain View, CA 94043
(650) 251-6100
www.omnicell.com

Omnicell and the Omnicell design mark, OmniBuyer, OmniCenter, OmniRx, OmniSupplier, Pandora, PandoraVIA, SafetyMed, SafetyStock, and Sure-Med are registered trademarks. Anesthesia TT, Anesthesia Workstation, Anywhere RN, Executive Advisor, FlexBin, Medication Surveillance, OmniDispenser, OmniLinkRx, OmniScanner, OmniTrack, Omni TT, Open Touch, OptiFlex, OptiFlex MobileTrack, Point-to-Point Medication Safety, ProServ1, SecureVault, See & Touch, SinglePointe, TempCheck, Touch & Go, vSuite, and WorkflowRx are trademarks of Omnicell, Inc. in the United States and internationally. All other trademarks and trade names are the property of their respective owners.

© 2008-2015 Omnicell, Inc. All rights reserved.

This guide is CONFIDENTIAL and designed only for Omnicell personnel and/or designated representatives.

Contents

Overview	5
Omnicell Hardware Architecture.....	5
Omnicell Hardware Requirements	5
OmniCenter/Color Touch.....	6
OmniCenter/Color Touch Electrical Requirements.....	6
OmniCenter/Color Touch General Electrical Requirements	6
OmniCenter/Color Touch UPS Protection.....	8
OmniCenter/Color Touch External UPS Protection.....	9
OmniCenter/Color Touch Radiated Emission Level Testing.....	10
OmniCenter/Color Touch Communication Requirements	10
OmniCenter/Color Touch Network Requirements.....	10
OmniCenter/Color Touch Remote Access.....	11
OCRA.....	11
OmniCenter Backup	12
OmniCenter Archives	12
Color Touch Cabinet Web Access.....	12
Color Touch G4 Platform Wireless Specifications	12
Color Touch Environment.....	14
Color Touch Transport/Storage Conditions.....	14
Color Touch Temperature Requirements	14
Color Touch Heat Dissipation.....	14
Color Touch Safety/Quality Certifications.....	15
Color Touch AUX/E-Box Specifications	16
Color Touch Auxiliary Box Specifications.....	16
Color Touch G4 E-Box Specifications	16
Savvy Mobile Medication Workstation Specifications	18
Savvy External Battery Charger Specifications.....	20
Omnicell Server Specifications.....	22
Omnicell Server Configuration.....	22
SinglePointe customers with 100+ devices and MO Routing Set to Patient Route.....	23
OmniCenter/Server Minimum Upgrade Requirements.....	23
Dell™ PowerEdge T320 Base Server - Tower Unit.....	24
Dell™ PowerEdge R320 Base Server - Rack Unit.....	25
Dell™ PowerEdge E630 Base + Server	26
Omnicell Virtual Server Specifications	28
OmniCenter Virtual Server Specifications.....	28
Key Differences Between Base and Base + Virtual Appliances	29
Windows 2012 Virtual Machine Configuration	30
Windows 2008 Virtual Machine Configuration	35
OmniCenter Software Requirements	43
Medication Label Printer Specifications.....	43
Medication Label Printer Hardware and Software Requirements.....	43

About the Medication Label Printer Labels..... 44

SATO and HP Laserjet Printer Part Numbers 44

SATO CL408NX Printer Specifications 44

Codonics Safe Label System (SLS) 500i Specifications..... 45

Omicell Cabinet Space Requirements 47

Omicell Cabinet Module Specifications..... 71

FlexLock 2.0 81

Refrigeration Options..... 82

Omicell Pharmacy Drawer Module Specifications..... 88

 High Security FlexBin Single-dose Drawer Specifications..... 89

 High Security Locking Bin Drawer Specifications 90

 Low Security Lighted Matrix and Matrix Drawer Specifications 92

Omicell Cabinet Drawings..... 96

WorkflowRx 102

WorkflowRx Hardware Specifications 102

WorkflowRx Electrical Requirements..... 103

 Carousel Computer Electrical Requirements 104

 Packager Electrical Requirements..... 107

WorkflowRx Communication Requirements 110

WorkflowRx Environment 111

 WorkflowRx Heat Dissipation 111

 WorkflowRx Seismic Restraints 112

WorkflowRx Safety/Quality Certifications 112

WorkflowRx Carousel and Packager Specifications..... 113

 WorkflowRx Large Carousel Dimensions 114

 WorkflowRx Special 20-Carrier Carousel Dimensions 117

 WorkflowRx Small Footprint Carousel Dimensions 120

 JV Medi Packager Specifications..... 122

 Yuyama Packager Specifications..... 124

Carousel Peripherals and Options..... 127

Packager Options..... 128

OmniLinkRx 129

Hardware Specifications..... 129

 OmniLinkRxServers 129

 OmniLinkRx Disk Sizing Tool 131

 OmniLinkRx Workstation Requirements 132

 OmniLinkRx Faxes 133

OmniLinkRx Software Requirements..... 134

OptiFlex 135

OptiFlex Electrical Requirements 135

OptiFlex Communication Requirements..... 135

 OptiFlex Network Requirements 136

 OptiFlex Remote Access 136

OptiFlex Environment Specifications..... 136

OptiFlex Cabinet Transport/Storage Conditions.....	136
OptiFlex Heat Dissipation.....	137
OptiFlex Safety/Quality Certifications.....	137
OptiFlex 11+ Computer Equipment Minimum Specifications.....	137
OptiFlex Server Configuration/Database.....	137
OptiFlex Platform Matrix.....	137
OptiFlex Inventory Control Module Computers.....	138
OptiFlex Point of Use Computers.....	138
Optiflex 12.0 Servers.....	140
OptiFlex Client Hardware/Software.....	141
OptiFlex Cabinet Specifications.....	141
Supply Modules.....	141
OptiFlex Scanner Mount.....	142
SecureVault.....	143
SecureVault Server Configuration.....	143
Anywhere RN.....	147
Anywhere RN System Requirements.....	147
Anywhere RN OmniCenter/Server Minimum Requirement.....	147
Anywhere RN Color Touch Cabinet Minimum Requirements.....	147
Anywhere RN Remote Workstation Network Requirements.....	148
Anywhere RN Interfaces.....	148
Anywhere RN Remote Workstation Requirements.....	148
Anywhere RN Mobile Cart Requirements.....	149
Anywhere RN Security Notes.....	149
Anywhere RN Network Notes.....	149
CSM.....	150
CSM Parts List.....	150
CSM Electrical Requirements.....	152
CSM Communication Requirements.....	152
CSM Network Requirements.....	152
CSM Remote Access.....	153
CSM Environment Specifications.....	153
CSM Transport/Storage Conditions.....	153
CSM Heat Dissipation.....	153
CSM Safety/Quality Certifications.....	153
CSM Hardware Specifications.....	154
CSM Cabinet Specifications.....	154
CSM Supply Modules and Peripherals.....	155
PandoraVIA Hardware Specifications.....	158
Appendix A: Read Height.....	160
Appendix B: Seismic Specifications.....	161

Appendix C: Cybernet iOne H19 Workstation Specifications 176

Overview

This product specifications document covers all Omnicell hardware products. This document can be used by marketing for quoting to customers in proposals. It can also be referenced by project managers and field engineers for implementation and installation purposes.

Most of the Omnicell hardware products are presented in the OmniCenter/Color Touch section. Unique hardware for other products (WorkflowRx, OmniLinkRx, Omnicell Supply Specialty, SecureVault) is covered in subsequent chapters. Refer to the OmniCenter/Color Touch section regarding common hardware.



Older technologies (G3, SureMed, Blue Screen, medium security drawers) that may still be supported but are no longer sold, are not included in this document.

Omnicell Hardware Architecture

Omnicell solutions are designed for use in the materials management department, nursing units, pharmacy, and specialty areas.

- Omnicell cabinets provide the convenience and security of a closed system, while also supporting management of external supplies.
- Omnicell pharmacy drawer modules can be installed along with supply zones, to create mixed-use cabinets. This unique option gives clinicians the convenience of a single point of access to both supplies and medications.
- Omnicell carousels and packagers serve in the pharmacy department. Carousels store incoming medications from vendors. Packagers prepare dose packets for delivery to cabinets.
- Mobile carts provide convenience and flexibility for storage and access of supplies and medications. They can be used for bedside applications.

Omnicell Hardware Requirements

Several site requirements must be met in order for Omnicell hardware to be installed. These requirement types are listed in each product section if applicable, including:

- Electrical
- Communication
- Environment
- Safety certification
- Hardware parameters

OmniCenter/Color Touch

This section covers the cabinet types that run OmniCenter and Color Touch software. Optional cabinet modules and pharmacy drawer modules are included.

The cabinet types include:

- One-, two-, three-cell cabinets
- Half-cell cabinet
- Mobile supply cart
- OmniRx
- OmniTT, Anesthesia TT
- Anesthesia Workstation
- Savvy Mobile Medication Workstation



Auxiliary cabinets are available for one-cell, two-cell, three-cell, half-cell, OmniRx, and OmniTT products. Auxiliary cabinets are connected to the main cabinet and do not have their own user interface.

OmniCenter/Color Touch Electrical Requirements

In addition to general requirements, this topic covers UPS and radiated emission level testing requirements.

OmniCenter/Color Touch General Electrical Requirements

Omnicell requires the facility to provide electrical service according to Omnicell equipment specifications. The facility is responsible for all electrical and cabling costs.

- One 115V AC outlet for each cabinet control unit and auxiliary unit in North America. For all other countries, consult the local electrical authority.
- All units must be within six feet of an electrical outlet.

Product	Operating Voltage (VAC)	Frequency	Operating Current	Power Consumption	G3 Fuse	G4 Fuse	Phase
One-, two- three- cell cabinets	85 - 264 AR (auxiliary) 90 - 250 AR (Color Touch) G4 one- two-cell Medical grade	50-60 Hz	2 A at 115 V - 230 V	150 W (Aux) 200 W (Color Touch)	4 A	6.3 A	Single

Product	Operating Voltage (VAC)	Frequency	Operating Current	Power Consumption	G3 Fuse	G4 Fuse	Phase
Half-cell, OmniRx, Omni TT	90 - 260 AR (Color Touch) 90 - 260 AR (auxiliary) Medical grade	50-60 Hz	1.25 A at 115 V 0.75 A at 230 V	200 W	4 A	6.3 A	Single
Mobile supply cart	90 - 260 AR Medical grade	50-60 Hz	1.25 A at 115 V 0.75 A at 230 V	200 W	4 A	4 A	Single
Anesthesia Workstation, Anesthesia TT	90 - 260 AR Medical grade	50-60 Hz	1.25 A at 115 V 0.75 A at 230 V	200 W	4 A	6.3 A	Single
Smart Mobile Cart	120VAC / 60Hz (Rio)	50-60 Hz			5 A	5 A	Single
Savvy Mobile Medication Workstation	90 - 260 AR Medical grade	50-60 Hz	2.5 A at 115 VAC 1.6 A at 230 VAC	200 W	n/a	4 A	Single
OmniCenter Server - Dell™ PowerEdge R320 Base Server	100-240 AR	50-60 Hz	10 A-5 A	1000 W			Single
FlexLock with TempCheck	FlexLock is powered by the cabinet, and no separate power is required						Single



Power and data connections are made to frames at the back right of the computer. The 1-, 2-, and 3-cell computers are 51-55" (129.54 - 139.7 cm) from the floor. Half-cell, OmniRx, and Anesthesia Workstation computers are 44-50" (111.76 - 127 cm) from the floor. The OmniRx TT computer in its frame is 15" (38.1 cm) from the surface the TT sits on. Omnicell power cords are 15 feet (4.57 m) in length.

The hospital should have its own emergency power source. Omnicell recommends that emergency power be provided to each unit with connections to red plugs.

Cabinets come with internal uninterruptible power supply (UPS) units. See the "[OmniCenter/Color Touch UPS Protection](#)" section. Omnicell can also provide external UPS units. See "[OmniCenter/Color Touch External UPS Protection](#)".

OmniCenter/Color Touch UPS Protection

To prevent power problems from damaging the computer, cabinets have a built-in UPS with surge-suppression circuitry. The UPS can provide the computer with up to 20 minutes of power when voltage levels become erratic or fail.

The facility is responsible for testing and changing the battery in UPS units.



The battery in the UPS unit must be connected during installation because Omnicell is required to disconnect battery cables prior to shipping. When connecting an OmniCenter server to an external UPS, do not plug the printer or computer monitor into the UPS unit.

This table describes the UPS parameters for the G4 platform.

Table 1: G4 Platform Internal UPS Specifications

Parameter	Specification
Voltage range	90-250VAC
Frequency	50-60Hz
Average current	1 A
Peak current	6A
Fuse	6.3A/250V Time-lag
Surge ratings	EN61000-4-5 Level 3
Battery recharge rate	6 hours

Parameter	Specification
Battery back-up time (typical): half load/full load	40 minutes/20 minutes
Full time EMI/RF filtering	Yes

OmniCenter/Color Touch External UPS Protection

If customers want to have added runtime in case of a power failure, Omnicell can recommend an external UPS for usage with one- two- three-cell cabinets, half-cell, OmniRx, OmniTT, Anesthesia Workstation, and Anesthesia TT.

The amount of additional time given by the UPS will vary depending on the Omnisupplier for which the UPS is being used. The facility is responsible for testing and changing the battery in UPS units.

This table describes the external UPS parameters.

Table 2: External UPS Specifications

Parameter	Specification
Voltage range	91-145 VAC
Frequency	60 Hz
Peak current	10.1A @ 100V 9.3A/110V 8.6A/120V
Power protection	Circuit breaker
Battery recharge rate	4-8 hours
Battery back-up time (typical):	Approximately two hours with Anesthesia Workstation (Varies depending on OmniSupplier model and installed options.)
Energy rating	1800 joules

OmniCenter/Color Touch Radiated Emission Level Testing

Omnicell tests its products for EMI, RFI and susceptibility, and conducted emissions. Cabinets meet Class B radiated emission levels, except for Savvy which is a Class A product.

Individual test reports showing test performed and results are in Agile under 62-92xx.

Products are compliant with the following tests:

- VCCI V-3(2010-04)
- FCC §15.307 Conducted Emissions
- FCC §15.305 Radiated Emissions
- Electrostatic Discharge (EN 61000-4-2)
- Electrical Fast Transients (EN 61000-4-4)
- Radiated RF Immunity (EN 61000-4-3)
- Conducted RF Immunity (EN 61000-4-6)
- Power Frequency Magnetic Fields (EN 61000-4-8)
- Surges EN (61000-4-5)
- EN 60601-1-2 36.202, Immunity
- Voltage Dips And Interruptions (EN 61000-4-11)
- CISPR 11 §5.1 Conducted Emissions
- CISPR 11 §5.2 Radiated Emissions
- CISPR 11 Standard, Class B or Class A limits
- ESD (EN 61000-4-2) Air Discharge = +/-8KV, Contact Discharge = +/-6KV

OmniCenter/Color Touch Communication Requirements

Communication considerations include network, remote access, OmniCenter Remote Access (OCRA), backup, archives, cabinet web access, and wireless specifications.

OmniCenter/Color Touch Network Requirements

The Omnicell equipment resides on the hospital's network infrastructure, which is responsible for the performance and security of the system.



The equipment should be set up behind the facility's firewall. If possible, the equipment should be in an isolated local area network segment or LANS.

However, Omnicell applications do have their own security features. They also support network connections between the cabinets and OmniCenter.

To ensure that the Omnicell system can interface properly with the facility network, the facility must provide:

- LAN or WAN with 100 Mbps or higher is preferred. 10 Mbps is the minimum requirement.
 - 802.11 a/b/g WLAN infrastructure and configuration for units requiring this option (Anesthesia Workstation, OmniSuppliers, and OmniRx units)
 - Category 5 or higher cabling from the switch to the jack for applicable units
-

- One network port for each cabinet and at least one for every OmniCenter or Interface Server (NIC bridging or teaming are options on current server lines).
- One static IP address, subnet mask, and gateway address for each cabinet and at least one for each server.
- DNS or WINS server addresses for name resolution (optional).

OmniCenter/Color Touch Remote Access

This topic covers communication protocols, options, and requirements for remote access.

Communication Protocols

OmniceLL primarily operates over TCP/IP and uses Health Level 7 (HL7) v.2.5 interface standards. Socket, FTP and MSMQ protocols are also used.

Options

- vSuite solution is preferred.
- Virtual private network (VPN) solutions are used only if vSuite is not supported
- T1 for service internet connection is recommended
- Telephone line with direct inward dial (DID) is seldom used

Requirements

- Web access on Port 443
- Port 80 for access to cabinets and OmniCenter web, prefer hardwired
- 128 encryption SSL (only for vDirector if used)
- One line per cabinet (if phone used)
- One to four lines per OmniCenter for remote diagnostics (if phone used)

OCRA

OmniCenter Remote Access (OCRA) allows remote access to the OmniCenter system application from any customer-provided computer system (using Windows 95 or higher). The computer system must support Microsoft® Terminal Services (client) software.

OCRA manages individual sessions that may be running at any one time. OCRA can access the OmniCenter Console application through Microsoft Terminal Services (TS) and Terminal Services Client (TSC). Terminal Services is a Windows server-based technology that enables an application to be run on the server, but controlled from a client computer.

The following items are required to operate OCRA:

- OCRA software
- OCRA license
- Omnicell Option Key
- Microsoft Terminal Services Server Client Access License(s)
- Microsoft Windows Server Client Access License(s)

The Omnicell Option Key is encoded with the allowable number of user sessions. Facilities may assign OCRA access to the number of users specified in the purchased OCRA configuration. For example, if the facility purchases rights to 10 User OCRA (Silver), sessions, then 10 individual users can access the OCRA. Omnicell

provides setup and configuration instructions, and the software CD. Once OCRA is enabled at the OmniCenter, users can then install the software on the applicable PCs.

The OCRA user account is set up during the manufacturing process.



Omicell obtains the Microsoft Terminal Services Client Access License and Microsoft Windows Server Client Access License, then installs the software for all network PC conversions. For more information, see the *OCRA Technical Guide* (P/N 67-3013).

With the exception of an optional hand-held mobile computer or bar code printer, the customer is responsible for the installation and hardware support of this feature.

OmniCenter Backup

The customer is responsible for burning archive data to a CD (tower) and moving data to the network attached storage (NAS).

Refer to *Omicell Implementation Guide* (#67-3004) for OmniBackup Checklist and *Omicell System Software Administration Guide* for the latest procedures.

OmniCenter Archives

The customer is responsible for rotating tapes (tower) and picking up data off the backup table.

Color Touch Cabinet Web Access

Cabinet web access is an optional feature. The cabinet computer can have an embedded version of Windows XP.

OmniExplorer is an optional web extension of OmniCenter, Port 80, and MSMQ. Web access uses a controlled embedded browser.

Color Touch G4 Platform Wireless Specifications

Wireless communication between the cabinets and the OmniCenter is accomplished using Intel's Centrino Advanced N-620 for Desktop adapter.

Omicell also still supports the Asus PCE-N15 adapter. The following table lists the wireless specifications.

Table 3: G4 Platform Wireless Specifications

Specification	Centrino Advanced-N 6205 for Desktop	PCE-N15
Connector Type	RP-SMA	RP-SMA

Specification	Centrino Advanced-N 6205 for Desktop	PCE-N15
Certificates	UL, C-UL, CB (IEC 60950-1), FIPS, FISMA	CE, FCC, C-Tick, IC
Authentication	WPA & WPA2, 802.1X (EAP-TLS, TTLS, PEAP, LEAP, EAP-FAST), EAP-SIM, EAP-AKA	WPA & WPA2
Authentication Protocols	PAP, CHAP, TLS, GTC, MS-CHAP, MS-CHAPv2	None
Encryption	64-bit, 128-bit WEP, AES-CCMP, TKIP	64-bit WEP, 128-bit WEP, AES-CCMP, TKIP
Antenna (Form)	PIFA (enclosed in plastic)	External Dipole (2)
Dimensions H x W x D; Weight	50.85 x 69.53 x 6.37 mm; 40.68g	120.5 x 21.6 x 22 mm; 62.6g
Operating Humidity	50% to 90% non-condensing	5 to 95% non-condensing
Operating Temperature	0 to 80°C	0 to 45°C
Operating System Compatibility	Windows 7 (32-bit), Vista, XP, 8, Linux	Windows 7 (32-bit), Vista, XP, Linux
Manufacturer	Intel	Asus
Operating Frequency	2.4 GHz, 5 GHz	2.4 GHz
Network Compliant Standards	IEEE 802.11 a/b/g/n	IEEE 802.11 b/g/n
Data Transfer Rate	Up to 300 Mbps	Up to 300 Mbps

Specification	Centrino Advanced-N 6205 for Desktop	PCE-N15
Interface Type	PCIe	PCIe
Status Indicators	On/Off	Link, Tx/Rx

Color Touch Environment

These general environment requirements must be met. Additional information is provided in separate topics.

- Adequate ventilation: 4" (10.16 cm) clearance around each Omnicell cabinet (from the wall and other cabinets)
- Adequate air flow
- A floor plan showing the location of where each cabinet is placed

Color Touch Transport/Storage Conditions

The maximum cabinet humidity exposure should not exceed 80% (without condensation). It is the customer's responsibility to maintain room temperature at or below 71°F (22° C).

See the recommended cabinet temperature ranges by item type in the table below. Document areas in the cabinet that are +6°F of the ambient temperature and note not to store sensitive medication in those areas.

Cabinet	Degrees Celsius	Degrees Fahrenheit
Medications	20-25°	68-77°
General Supplies (with brief deviations)	15-30°	59-86°

Color Touch Temperature Requirements

The operating temperature for most Omnicell cabinets is 5 to 35° C. The storage temperature is from -40 to +85° C.

Color Touch Heat Dissipation

This table contains useful information for determining a site's heating and ventilation setup so that room temperatures can be maintained with the cabinets installed.

Table 4: G4 HVAC Table Heat Dissipation Advisories

Cabinet	Heat Dissipation
1-, 2-, and 3-cell	200-600 BTU/hr
Half-cell, OmniRx, OmniTT, Anesthesia TT	200-400 BTU/hr
Anesthesia Workstation	200-400 BTU/hr
Supply Mobile Cart	304-443 BTU/hr

Color Touch Safety/Quality Certifications

Omicell cabinets are certified according to the Canadian Standards Association (CSA) and Conformity European (CE) mark standards. They are exempt from Food & Drug Administration (FDA) certifications.

- Omnicell cabinets meet fire protection standards with their CSA and CE certification.
- Omnicell is ISO 9001:2000 compliant.
- The Anesthesia Workstation (AWS) and Supply Mobile Cart (55CTMC) are CSA and CE certified medical electrical equipment/systems, with a medical grade power supply.
- The G4 products are CSA and CE certified medical electrical equipment/systems, with a medical grade power supply.

Color Touch Seismic Specification

See the California Building Code documents OPA 0331 (1-, 2-, and 3-cell cabinets and OmniRx) in "[Appendix B: Seismic Specifications](#)". It contains seismic specifications details. These documents were prepared by Degenkolb Engineers.



The state of California is in the process of approving the seismic specification for the packager.

Go to the following link for the OSHPD pre-approval list:

<http://www.oshpd.ca.gov/FDD/Pre-Approval/OPAIndex.pdf>

Color Touch AUX/E-Box Specifications

Color Touch Auxiliary Box Specifications

Cabinets with an auxiliary (aux) box are connected with 25-foot cables to a main cabinet with a CT PC box for communication to the OmniCenter. An aux box does not have direct interface capability.

Table 5: Aux Box Specifications

Item	Omnicell Configuration (Dell part #)
Base System	Provides power and communication line to OmniSupplier Aux
Output Voltage	12V and 5V
Max Amps	5A for 12V; 10A for 12V
Input Voltage	85-264 VAC
Operating Temperature	5°C to 35 °C
Storage Temperature	-40 °C to 85 °C
Dimensions (H x W x D)	6.56" x 22.5" x 21.3" / 16.66cm x 57.15cm x 54.1cm
Feature	Setting options to connect to external PC or main cabinet.

Color Touch G4 E-Box Specifications

The G4 CT Console, Rx, and AWS allow direct interface with a cabinet via a touch screen, keyboard, and monitor. They also communicate with the OmniCenter.

Table 6: G4 Color Touch E-Box Specifications

Item	Omnicell Configuration
Processor	Intel® I3-540 CPU at 3.06GHz
Memory	2GB, DDR3-1333, PC3-10600, CL9, 240PIN, SODIMM

Item	Omnicell Configuration
Hard Drive	500 GB, SATA 7200RPM, WD5000AAKX Enterprise
Operating System	Microsoft Windows 7 Embedded (32-bit)
Display	12.1" LCD with LED backlight for CT console; 15.0" LCD with LED backlight for Rx and AWS
Video Controller	Integrated Graphics GMA HD
Ethernet	One (1) RJ45 10/100/1000 Ethernet port (LAN1, Intel 82578DM) and one (1) RJ45 10/100/1000 Ethernet port (LAN2, Intel 82574L)
Keyboard	Keyboard, USB, QWERTY
Mouse	None
Floppy Disk Drive	None
CD-ROM or DVD-ROM Drive	None
Sound	Single speaker
Printer	Thermal receipt roll printer and optional label printer
UPS	Built-in (approximately 20 minutes back-up)
PC box Weights	G4 PC Console: 80 lb (36.29 kg)
	E-Box: 40 lb (18.14 kg)
	OmniRx: 80 lb (36.29 kg)
	AWS: 90 lb (40.82 kg)

Item	Omnicell Configuration
Notes:	Omnicell proprietary interfaces for cabinet-internal communication
	Auxiliary proprietary communication ports for external cabinet communications
	Proprietary peripheral ports for external return bin, FlexLock and other devices
	Part Number for printer paper (1-, 2-, and 3-cell cabinets) 95-6015 (paper, thermal, 92 mm roll, 88 mm wide)

Savvy Mobile Medication Workstation Specifications

The Savvy Mobile Medication Workstation is used to access all hospital software applications while providing safe and secure transport of medications in patient-specific drawers.

Table 7: Savvy Mobile Medication Workstation Specifications

Savvy Mobile Medication Workstation Specifications	
Processor	Intel SP9300 CPU; 2.26 GHz C2D, 6M L2 cache; ultra low power
Memory	4 GB, 800 MHz DDR2 SO-DIMM
Data Storage	80 GB SSD
Operating System	Windows 7 (32-bit)
Display	TFT active matrix with touch screen - 17" diagonal, 1280 x 1024 maximum resolution, optional privacy glass
Video Controller	Integrated SXGA 1280 x 1024 32-bit color, 1 external DVI port
Ethernet	1 external 10/100 Mbps Ethernet port
Keyboard	USB, QWERTY, optional sealed keyboard

Savvy Mobile Medication Workstation Specifications	
Mouse	USB, optional sealed mouse
Floppy Disk Drive	None
CD-ROM or DVD-ROM Drive	None
Sound	
Printer	None
Wireless	Intel Centrino Advanced - N6205, 802.11 a/b/g/n; WiFi wireless adapter
USB Ports	2 external USB ports
Power System	
Input Voltage	90-264VAC @ 3.5 A maximum at 115VAC, 1.6A maximum at 230VAC
Output Voltage	120VAC @ 60 Watts maximum
Charger	4 amps maximum
Battery type	Lithium-Ion, hot swappable, up to 18 hrs runtime (1 or 2 batteries, depending on configuration)
Short-Circuit Protection	AC 4 A Fuse, 12 VDC 7 A Fuse, Motor 10 A Fuse, Inverter 5 A Resettable Fuse
Status Indicator	On-screen display; LED indicators at base; LED indicators on each battery case
General	
Base Dimensions	16" W x 16" (40.64 cm x 40.64 cm)

Savvy Mobile Medication Workstation Specifications

Work Surface Area	17" x 12" (43.18 cm x 30.48 cm)
Work Surface Height	36" - 46" (91.44 cm - 116.84 cm)
Device Height	Adjustable between 55" (139.7 cm) and 65" (165.1 cm) (including monitor)
Construction	Cast aluminum and plastic injection
Finish	Powder coat
Wheels	4 swivel (2 locking) casters 5" (12.7 cm) diameter, polyurethane tread
Approvals	CE/CSA, UL a60601-1, FCC
Drawers	Up to 12 locking drawers with Guiding Lights technology, 3" (7.62 cm) and 6" (15.24 cm) deep drawer options

Savvy External Battery Charger Specifications

The Savvy External Battery Charger is an optional feature that enables charging the Savvy batteries externally from the cart.

This table shows the specifications for the Savvy External Battery Charger.

Table 8: Savvy External Battery Charger Specifications

Model Number:	MMM-HDW-001
Approvals	TUV, IEC60601-1, FCC
Number of battery slots	2 independent
Recharge Time	5-6 hours from fully depleted condition
Input Voltage	100-240VAC @ 3.0 A maximum at 115 VAC, 1.5 A maximum at 230 VAC

Input Frequency	50Hz/60Hz
Input Current	3.0A max at 115VAC
Inrush Current	60A max at 100-240VAC, 25°C
Standby Power Consumption	Less than 1W
Efficiency	Greater than 80% at 100-240VAC input and output full load
Rated Output	16.4VDC ~ 16.6VDC
Charge current	3800 mA ~ 4200 mA
LED Indication	OFF: No charging; Blinking orange: Battery is charging; Green: Battery is fully charged; Red: problem with battery
Leakage Current	Less than 0.1 mA for Class II
Mechanical Dimensions	16.75" W (42.55 cm) x 11 " H (27.94 cm) x 7.75" D (19.69 cm) with two batteries installed
Operating Temperature	0 °C ~ 40 °C
Relative Humidity	10% ~ 90%
Storage Temperature	-20 °C ~ 70 °C (non-condensing)
Vibration and Shock	MIL-STD-810D
Weight	9 lb without batteries

Omnicell Server Specifications

Omnicell delivers the latest models of available hardware. CPU speed, memory size, hard drive size, and other features are improved frequently.

Omnicell Server Configuration

This table describes the Omnicell server configuration for version 20.0.

The following information applies to the Omnicell server models listed in the table below.

- Microsoft® Windows® 2012 R2 Server and SQL database 2012 Standard Edition
- Multi-site option is supported up to the maximum number of sites and total number of devices connected on a single database.
- Multiple-installation option is supported for up to ten (10) CPCs.

Server Type	Omnicell Model	OS/Database	Maximum Cabinets/Devices Supported
Base + Physical	Dell PowerEdge T630	Win R2 2012 (64-bit), SQL2012 Standard Edition	1,000*
Base + Virtual	Virtual Appliance	Win R2 2012 (64-bit), SQL2012 Standard Edition	600*
Base Physical	Dell PowerEdge R320/T320	Win R2 2012 (64-bit), SQL2012 Standard Edition	100
Base Virtual	Virtual Appliance	Win R2 2012 (64-bit), SQL2012 Standard Edition	100
Base (Win2008)** Physical	Dell PowerEdge R320/T320	Win2008 (32-bit), SQL2008 Workgroup Edition	100
Base (Win2008)*** Virtual	Virtual Appliance	Win2008 (32-bit), SQL2008 Workgroup Edition	100



*For sites using Med Order Routing > Patient Route, on-demand med order broadcasting must also be enabled and cabinets must be running 19.5 or higher software.

**Base Windows 2008 server ships with Omnicell 18.5. Software upgrade is required at time of installation.

***Base Windows 2008 virtual server ships with Omnicell 18.0. Software upgrade is required at time of installation.

On-demand Med Order Broadcasting

A new option enables on-demand requests of the med order list in real time when a nurse selects a patient who is not in the cabinet's area. This change was made to allow greater performance and support for more devices on the server. The option only applies when the med order routing is set to patient route; it does not apply when med order routing is set to patient area.

SinglePointe customers with 100+ devices and MO Routing Set to Patient Route

For servers to support the maximum number of devices, Omnicell recommends creating an additional communication queue to receive patient and med order information from the Pharmacy Information System (PIS). Queues help to streamline message processing, accelerate transaction information synchronization, and improve information exchange between OmniCenter and devices.

- Recommended ways to divide queues:
 - By site if customer has more than one site.
 - By even/odd patient ID (PID) (e.g., data for even patient to first queue; odd patient to second queue).
- Creating queues must be performed by an Omnicell interface analyst or field engineer.
- Creating queues can be performed before or after upgrading to 19.0 or higher. Omnicell recommends doing this before the upgrade.

OmniCenter/Server Minimum Upgrade Requirements

Certain minimum requirements apply for upgrade of OmniCenter servers.

- OmniCenter software version must be equal to or greater than the Color Touch cabinets, Open Supply Omnis, Central Pharmacy Manager, and Controlled Substance Manager client software versions.
- OmniCenter must be upgraded before cabinets/clients.
- Server purchase required when minimum server software and hardware requirements are not met. Omnicell will assist in the upgrade of customer data as part of the new server installation. Minimum supported versions for upgrade to Omnicell 20.0 and later are:
 - Microsoft Windows Server 2008 or 2012
 - Omnicell 16.3 or later
- Backward compatibility: CT = 16.1 and higher, Savvy = 18.0 Win 7 only. Savvy WinXP is not supported on 19.0 and later.

For purposes of calculating number of devices, device is defined as follows:

- One cabinet = one Color Touch cabinet configured in any mode (pharmacy, supply, pharmacy/supply, Anesthesia Workstation, etc.)
- One Controlled Substance Manager (CSM) = one cabinet.
- One Central Pharmacy Manager (CPM) = one cabinet.
- Four Savvy Mobile Medication Workstations = one cabinet. For example, 80 Savvy units = 20 cabinets.

OmniCenter can be installed with the following options:

- Single server install: single server per hospital site
- Multi-site install: one database for multiple sites. The number of sites is limited to the number of Omnicell cabinets or devices connected.
- Multi-install: one server with separate databases for up to 10 sites (Windows 2012 servers) or 5 sites (Windows 2008 servers).

Dell™ PowerEdge T320 Base Server - Tower Unit

This is the tower version of the server recommended for customers with 100 or fewer cabinets.

The following table contains its specifications.

Table 9: Dell PowerEdge T320 Base Server Configuration

Item	Omnicell Configuration (Dell part #)
Operating System	Windows R2 Server 2012, Standard Embedded R2 (64-bit) or Windows Server 2008 Standard (32 Bit)
Form Factor	Tower - 5U Rackable
Base Unit	PowerEdge T320, Intel Xeon E-24XX v2 Processors (210-ACDX)
Processor	1 x Intel Xeon E5-2407 v2 - 2.40GHz, 10M Cache, 6.4GT/s QPI, Turbo, 4C, 80W, Max. Mem. 1333 MHz (338-BEBO)
Memory - 16GB	1 x 16GB RDIMM, 1600 MT/s, Low Volt, Dual Rank, x4 Data Width (319-1812)
Network Card	On-Board Broadcom 5720 Dual Port 1 GB LOM (430-4715)
Hard Drive	2 x 146GB 15K RPM SAS 6Gbps 2.5 in Hot-plug Hard Drive (342-0427)
	6 x 300 GB 10K RPM SAS 6Gbps 2.5 in Hot-plug Hard Drive (342-0429)
Hard Drive Controller	PERC H710 Adapter RAID Controller, 512MB NV Cache, Full Height (342-4048)

Item	Omnicell Configuration (Dell part #)
RAID Controller Configuration	RAID 1 + RAID 10 for H710/H310 (2 + 6 HDDs in pairs) (331-6980)
DVD-ROM Drive	DVD+/- RW, SATA, Internal (318-2215)
Power Supplies	Dual, Hot-plug, Redundant Power Supply (1+1), 495W (331-4603) Power Distribution Board for Hot Plug Power Supplies (331-7658)
Power Cord	2 x NEMA 5 -15P to C13, 15 amp, wall plug, 10 feet / 3 meter (310-8509)
Remote Management	iDRAC7 Express (331-3481)
Dimensions	22.77" (57.84 cm) W x 18.56" (47.13 cm) H x 12.12" (30.79 cm) D (includes caster or foot)
Weight	65 lb (29.55 kg)

Dell™ PowerEdge R320 Base Server - Rack Unit

This is the rack version of the server recommended for customers with 100 or fewer cabinets.

The following table contains its specifications.

Table 10: Dell PowerEdge R320 Base Server Configuration

Item	Omnicell Configuration (Dell part #)
Operating System	Windows Server R2 2012, Standard Embedded R2 (64-bit) or Windows Server 2008 Standard (32 Bit)
Form Factor	1U Rack
Base Unit	PowerEdge R320, Intel Xeon E-24XX v2 Processors (210-ACCX)
Processor	1 x Intel Xeon E5-2407 v2 - 2.40 GHz, 10 M Cache, 6.4GT/s QPI, Turbo, 4C, 80W, Max. Mem.: 1333MHz (338-BDZR)

Item	Omicell Configuration (Dell part #)
Memory - 16GB	1 x 16GB RDIMM, 1600 MT/s, Low Volt, Dual Rank, x4 Data Width (319-1812)
Network Card	On-Board LOM 1 GBE (Dual Port for Racks and Towers, Quad Port for Blades) (430-4715)
Hard Drive	2 x 146 GB 15K RPM SAS 6 Gbps 2.5 in. Hot-plug Hard Drive (342-0427) 6 x 300 GB 10K RPM SAS 6 Gbps 2.5 in. Hot-plug Hard Drive (342-0429)
Hard Drive Controller	PERC H710 Integrated RAID Controller, 512MB NV Cache, Full Height (342-3529)
RAID Controller Configuration	RAID 1 + RAID 10 for H710/H310 (2 + 6 HDDs in pairs) (331-6980)
DVD-ROM Drive	DVD+/- RW, SATA, INTERNAL (318-2215)
Power Supplies	Dual, Hot-plug, Redundant Power Supply (1+1), 495W (331-4603) Power Distribution Board for Hot Plug Power Supplies (331-7658)
Power Cord	2 x NEMA 5 -15P to C13, 15 amp, wall plug, 10 feet / 3 meter (310-8509)
Remote Management	iDRAC7 Express (331-3481)
Dimensions	22.77" (57.84 cm) W x 8.58" (21.8 cm) H x 18.56" (47.13 cm) D
Weight	65 lb (29.55 kg)

Dell™ PowerEdge E630 Base + Server

This is the high-capacity server, recommended for existing customers with more than 100 cabinets or new customers projected to have more than 100 cabinets.

The following table contains its specifications.

Table 11: Dell PowerEdge E630 Base + Server Configuration

Item	Omicell Configuration (Dell part #)
Operating System	Windows R2 Server 2012, Standard Embedded R2 (64-bit)
Form Factor	Tower 5U Rackable
Base Unit	Dell PowerEdge T630 Server (210-ACWJ)
Processor #1	Intel Xeon E5-2637 v3 - 3.5 GHz, 15 M Cache, 9.60 GT/s QPI, Turbo, HT, 4C/8T (135 W) Max Mem 2133 MHz (338-BFFP)
Processor #2	Intel Xeon E5-2637 v3 - 3.5 GHz, 15 M Cache, 9.60 GT/s QPI, Turbo, HT, 4C/8T (135 W) Max Mem 2133 MHz, 2nd Processor (374-BBGW for two)
Memory	32 GB RAM - 2 x 16 GB RDIMM, 2133 MT/s, Dual Rank, x4 Data Width (370-ABUG); 2133 MT/s RDIMMS (370-ABUF)
Network Card	Embedded NIC - Intel Dual-port 1GbE LOM
Hard Drive	6 x 1.2 TB 10 K RPM SAS 6 Gbps 2.5 in. Hot-plug Hard Drive, 13 G (400-AEFO)
	10 x 300 GB 15 K RPM SAS 6 Gbps 2.5 in. Hot-plug Hard Drive, 13 G (400-AEEH)
Hard Drive Controller	PERC H730 RAID Controller, 1 GB NV Cache (405-AADT)
Power Supplies	Single, Hot-plug Power Supply (1+0), 495 W (450-ADWP)
Power Cord	NEMA 5-15P to C13 Wall Plug, 125 Volt, 15 AMP, 10 Feet (3m), Power Cord, North America (450-AALV)
Remote Management	iDRAC8 Express, integrated Dell Remote Access Controller, Express (385-BBHN)
W x H x D	19" x 5U x 29.6" (48.26 cm x 5U x 75.18 cm)

Item	Omnicell Configuration (Dell part #)
Weight	82.83 lb (37.57 kg)

Omnicell Virtual Server Specifications

Virtualization allows the IT administrator to run one or more virtual machines on top of one physical server. Omnicell supports dedicated or hypervisor virtualization using VMware's vSphere [5.x].

This approach eliminates the need for a host or secondary operating system to be installed on the server hosting the virtual machines. It reduces the amount of overhead required to run the virtualization software. For more information about virtualization, see the *Omnicell Virtualization Technical Guide* (67-3074).

OmniCenter Virtual Server Specifications

OmniCenter Virtual Appliance ships as an all-in-one VM with Windows Server 2012R2, SQL Server 2012R2, and the OmniCenter application pre-installed.

VMware supports Windows Server 2012 Guest Operating System only on ESXi 5.0 Update 2 and above. [Link to VMware Knowledge Base.](#)

ESX Version	Supported?
ESXi 4.x and below	No
ESXi 5.0	No
ESXi 5.0 Update 2 and above	Yes
ESXi 5.1 and above	Yes
ESXi 6.0	No

Number of Devices

Server Type	Make/Model	OS/Database	Max # of Devices Supported	Multi-Site Support	Multi-Installation Support
Base + Virtual	Virtual Appliance	Win 2012 R2 (64-Bit) SQL 2012	600*	Yes	Yes - Max 5 CPC
Base Virtual	Virtual Appliance	Win 2012 R2 (64-Bit) SQL 2012	100	Yes	Yes - Max 5 CPCs
Base (Win2008)** Virtual	Virtual Appliance	Win2008 (32-bit), SQL2008	100	Yes	Yes - Max 5 CPCs



*600 cabinets are supported for Patient Routing on OmniCenter v. 19.5 and later and Color Touch v. 19.5 and later. For versions below 19.5, 225 cabinets are supported for Patient Route. Med order routing is set at OmniCenter > Administration > Medication Order Setup > Med Orders > Med Order Routing.

**Base Windows 2008 Virtual server ships with Omnicell 18.0. Upgrade to 18.5 occurs at time of installation.

For purposes of calculating number of devices, device is defined as follows:

- One cabinet = one ColorTouch cabinet configured in any mode (pharmacy, supply, pharmacy/supply, NarcVault, Anesthesia, and so on).
- One Controlled Substance Management (CSM) = one cabinet
- One Central Pharmacy (CP) = one cabinet
- Four Savvy Mobile Medication Workstations = one cabinet. For example, 80 Savvy units = 20 cabinets.

Key Differences Between Base and Base + Virtual Appliances

This table lists key differences between the Base and Base + virtual appliances.

	Base VA	Base + VA
vCPU	4	8

	Base VA	Base + VA
SQL 2012 R2 License	Licensed for 4 Cores	Licensed for 8 Cores
vRAM	16 GB	32 GB
Virtual Disks (thin provisioning OK)	C: 50 GB, D: 500 GB, E: 32 GB	C: 50 GB, D: 500 GB, E: 500 GB, F: 50 GB

Windows 2012 Virtual Machine Configuration

This topic describes the individual configurations for the Base and Base + virtual machines and the configurations that are common to both.

Base Virtual Appliance - OmniCenter, OptiFlex, WorkflowRx, OmniLinkRx

- OmniCenter Product software version 18.5 or greater
- OptiFlex 11.x or greater
- WorkflowRx 7.x or greater
- OmniLinkRx 6.0 or greater
- Operating system: Windows Server 2012R2

OmniCenter Base Virtual Appliance Configuration - up to 100 Cabinets		
Processor	4 vCPU	1 Socket x 4 Cores
Memory	16 GB RAM	With provision to increase memory to VM if needed
NIC	1 NIC	With adapter type set to VMXNET3
Disk Space C:	50 GB	For OS and MSMQ
Disk Space D:	500 GB	For app and SQL - with an option to extend up to 1024 MB (1 TB) to support 7 years historical data. Customer should ensure that sufficient space exists for expansion up to 1 TB on LUN where OmniCenter Virtual Appliance is being deployed.
Disk Space E:	32 GB	For Windows Pagefile. Customers who use SAN replication mechanism can deploy this VMDK file on storage which is not replicated.

OmniCenter Base Virtual Appliance - Omnicell Interface Services (OIS) v. 6.x or greater

Processor	4 vCPU	1 Socket x 4 Cores
Memory	8 GB RAM	With provision to increase memory to VM if needed
NIC	1 NIC	With adapter type set to VMXNET3
Disk Space C:	50 GB	For OS, application, and MSMQ
Disk Space D:	250 GB	For app and SQL - with an option to extend up to 1024 MB (1 TB) to support 7 years historical data. Customer should ensure that sufficient space exists for expansion up to 1 TB on LUN where OmniCenter Virtual Appliance is being deployed.
Disk Space E:	16 GB	For Windows Pagefile. Customers who use SAN replication mechanism can deploy this VMDK file on storage which is not replicated.

Base + Virtual Appliance

This configuration supports up to 600 cabinets. OmniCenter product software version must be 18.5 or greater.

OmniCenter Base +Virtual Appliance Configuration - up to 600 Cabinets

Processor	8 vCPU	1 Socket x 8 Cores
Memory	32 GB RAM	With provision to increase memory to VM if needed
NIC	1 NIC	With adapter type set to VMXNET3
Disk Space C:	50 GB	For OS and MSMQ

OmniCenter Base +Virtual Appliance Configuration - up to 600 Cabinets

Disk Space D:	500 GB	For app and SQL Production Databases - with an option to extend up to 2048 GB (2 TB). Customer should ensure that sufficient space exists for expansion up to 2 TB on LUN where OmniCenter Virtual Appliance is being deployed.
Disk Space E:	500 GB	For SQL Historic/Archive Database and SQL Full and Transaction Log Backups with an option to extend up to 1024GB (1 TB) to support 7 years historical data.
Disk Space F:	50 GB	For Windows Pagefile. Customers who use SAN replication mechanism can deploy this VMDK file on storage which is not replicated.

Minimum Requirements for Deploying Windows 2012 R2 Virtual Appliance

These requirements are common to both Base and Base+ deployments)

OmniCenter Windows 2012 R2 Virtual Appliance Minimum Requirements

ESXi Version	ESXi 5.0 Update 2 and above	VMware supports Windows Server 2012 only on ESXi 5.0U2 and above. Link to VMware Knowledge Base.
ESXi Host - Processor	Intel Xeon E5 (SandyBridge, IvyBridge series and higher); Intel Xeon 5600/3600 (Westmere) series or higher	Intel Xeon E5-2440 (SandyBridge family) or Intel Xeon IvyBridge family is highly recommended.
Virtual Machine - Processor Resource Requirements	(Base) 1-100 cabinets/devices, 10 GHz (4 vCPU x 2.5 GHz) (Base +) 1-100 cabinets/devices, 20 GHz (8 vCPU x 2.5 GHz)	OmniCenter VM on Windows 2012 R2 is extremely processor intensive. For Base + deployment, Omnicell recommends deploying OmniCenter Virtual Appliance in a VM cluster which has high-powered processors, or on a dedicated ESXi host with no other processor-intensive workload on that host/cluster.

OmniCenter Windows 2012 R2 Virtual Appliance Minimum Requirements

	(Base +) 300-600 cabinets/devices, 30 GHz (8 vCPU x 3.7 GHz)	
ESXi Host - Power Management	Ensure BIOS setting for power is configured for "maximum performance"	
Virtual Machine - Hardware Version	Ensure VM is upgraded to latest Virtual Machine Hardware Version. ESXi 5 VM Hardware version is 8. ESXi 5.1 VM Hardware Version is 9, ESXi 5.5 VM Hardware Version is 10. ESXi 6.0 uses VM Hardware Version 11.	To support backward compatibility (for those customers still on ESXi 5U1), OmniCenter 18.5 Virtual Appliance ships with VM hardware version 8. If customer has later ESXi version they should upgrade VM after deployment by right-clicking on VM and selecting "Upgrade Virtual Hardware" drivers.
Virtual Machine - Anti-Virus	Ensure anti-virus exclusions are in place per Omnicell recommendation	Anti-virus exclusions recommended by Omnicell should be adhered to prevent severe performance degradation.
Storage - IOPS requirements	5,000 IOPS (Input/Output Operations per second) @ 5 ms or less latency	Typical workload of OmniCenter can generate up to average IOPS approximately 3,000 with occasional spikes up to 15,000.

OmniCenter Windows 2012 R2 Virtual Appliance Minimum Requirements

Storage - Average Disk Response Time within Windows	Average Disk response time within Windows should be 25 ms or less	Occasional spikes are acceptable.
Storage - Disk latency measurement	After initial deployment of appliance in customer environment but before production use, Omnicell may measure disk response time and IOPS, and document for future reference.	Should any performance issue occur post production deployment due to changes in customer virtual infrastructure, Omnicell will refer to this value to customer IT before troubleshooting any performance issues.
Storage - Disk provisioning	Thin or Thick	Thick disk provisioning recommended.
Storage - LUN recommendation	OmniCenter VM is very IO intensive (MSMQ, SQL) and is sensitive to storage/disk latency. Optimal performance is seen when VM is deployed on a LUN with dedicated set of drives.	Omnicell recommends deploying OmniCenter 18.5 Virtual Appliance on a dedicated LUN/DataStore made up on dedicated set of at least 16 or more 10K/15K RPM spindles (disks) regardless of SAN cache size. SAN made up of 7.2K RPM disks is not recommended and should not be used to avoid severe performance degradation and possible unscheduled downtime.

OmniCenter Windows 2012 R2 Virtual Appliance Minimum Requirements		
VMware - Support	Customer should have current production support agreement with VMware.	OmniceLL will help triage any performance issue escalation with VMware, but customer should first open ticket with VMware Technical Support.
Customer - IT Support	24/7 IT Support available at customer facility.	Troubleshooting virtual infrastructure issues can be a complex and time-consuming effort. Due to the mission-critical nature of the OmniCenter application, customer should have appropriate resources (VMware Admin, Storage Admin, Windows Admin, Anti-Virus Admin) available for troubleshooting any performance issues with deployed OmniCenter Virtual Machine.
OmniceLL - vSuite	OmniceLL vSuite proactive monitoring and remote access.	
OmniceLL - Virtualization Minimum Requirement policy	Customer agrees to comply with Virtualization minimum requirement policy.	Refer to Page 2 of the document http://www.omnicell.com/sitecore/~/_media/Files/PDFs/SVPolicy.pdf

Windows 2008 Virtual Machine Configuration

This topic describes the individual configurations for the Base and Base + virtual machines and the configurations that are common to both.

Windows 2008 Base Virtual Appliance - OmniCenter, OptiFlex, WorkflowRx, OmniLinkRx

- OmniCenter Product software version 17.1 or greater
- OptiFlex 11.x or greater
- WorkflowRx 7.x or greater
- OmniLinkRx 5.6 or greater
- OmniceLL Interface Services (OIS) v. 5.x or greater
- Operating system: Windows Server 2012R2

OmniCenter Base Virtual Appliance Configuration - up to 100 Cabinets

Processor	4 vCPU or 6 vCPU	1 Socket x 4 Cores or 1 Socket x 6 Cores. See "Virtual Machine - Number of sockets and cores" below.
Memory	4 GB RAM	
NIC	1 NIC	
Disk Space C:	50 GB	For OS and MSMQ.
Disk Space D:	250 GB	For app and SQL - with an option to extend up to 1024 MB (1 TB) to support 7 years historical data. Customer should ensure that sufficient space exists for expansion up to 1 TB on LUN where OmniCenter Virtual Appliance is being deployed.
Disk Space E:	32 GB	Pagefile.

OmniCenter Base Virtual Appliance Deployment Requirements

ESXi Host - Processor	Intel Xeon 5600/3600 Series or higher	ESXi Host should have Intel Xeon 5600/3600 Series (Westmere-EP) or higher. Intel Xeon E5-2440 (SandyBridge family) or higher is highly recommended.
ESXi Host - Power Management	Ensure BIOS setting for power is configured for "Maximum Performance"	With provision to increase memory to VM if needed

OmniCenter Base Virtual Appliance Deployment Requirements

ESXi Host - Hyper threading and SQL licensing	<p>To comply with Microsoft SQL Server 2008 Licensing, physical processor should have one of the following:</p> <ul style="list-style-type: none"> • Four or more cores with hyper threading off • Four or more threads with hyper threading on 	Refer to Microsoft SQL Server 2008 Licensing Guide
Virtual Machine - Number of sockets and cores	4 vCPU (1 Socket, 4 Cores) or 6 vCPU (1 Socket, 6 Cores)	Match host processor physical cores for best performance. For example, if ESXi host processor has 4 Cores, choose 1 Socket 4 Cores. If host has 6 core processors, choose 1 Socket 6 Cores.
Virtual Machine - Hardware Version	<p>Ensure VM is upgraded to latest VM Version. For example,</p> <ul style="list-style-type: none"> • ESXi4 VM hardware version is 7 • ESXi5 VM hardware version is 8 • ESXi5.1 VM hardware version is 9 	To support backward compatibility, Omnicell ships Virtual Appliance with hardware version 7. If you have a newer ESXi version, after deploying the Virtual Appliance, upgrade VM to the latest supported hardware version. This can be done by right-clicking the powered off VM and choosing "Upgrade Virtual Hardware". For more details refer to the VMware Knowledge Base: : VMware Knowledge Base

OmniCenter Base Virtual Appliance Deployment Requirements

Virtual Machine - Memory	Use Memory Reservation / ESXi 5.1 - Check "Reserve all guest memory (All Locked)"	To ensure OmniCenter VM receives 4 GB RAM allocated to it at all times to avoid memory starvation during ESXi Host memory overcommit situation. For instructions to configure memory reservation, see "Configuring Memory Reservation" on page 1-24.
Virtual Machine - AntiVirus	Ensure Anti-virus exclusions are in place per Omnicell recommendation	Severe performance degradation will occur if anti-virus exclusions are not adhered to.
Storage - IOPS Requirements	5,000 IOPS (Input/Output Operations Per Second) @ 5 ms or less latency	Extensive testing of OmniCenter application shows that with typical workload, average IOPS is approximately 3,000 with occasional spikes up to 15,000.
Storage - Disk Provisioning	Thin or Thick	Omnicell highly recommends using thick disk provisioning.
Storage - Drive RPM	Minimum 15 K RPM drives	
VMware - Support	Customer has current production support agreement with VMware	Omnicell will help triage any performance issue escalation with VMware, but customer should first open ticket with VMware Technical Support.
Customer - IT Support	24x7 IT Support available at customer facility	Due to mission-critical nature of OmniCenter application and complexity inherent to virtual infrastructure, customer should have appropriate resources (VMware Administrator, Storage Administrator, Windows Administrator, Anti-Virus Administrator) available for troubleshooting any performance issues with deployed OmniCenter Virtual Machine.

OmniCenter Base Virtual Appliance Deployment Requirements

Omnicell - vSuite	Omnicell vSuite proactive monitoring and remote access	
Omnicell - Virtualization Minimum Requirement Policy	Customer agrees to comply with Virtualization Minimum Requirement Policy	Refer to page 2 of the document http://www.omnicell.com/sitecore/~ /media/Files/PDFs/SVPolicy.pdf

Windows 2008 Base + Virtual Appliance

- OmniCenter product software version: OmniCenter v17.1 or greater
- Number of cabinets supported: Up to 225
- The main difference between the Base and Base + Virtual Appliances is storage requirements. Dedicated storage must be allocated to meet OmniCenter application performance requirements.

OmniCenter Base +Virtual Appliance Configuration

Processor	4 vCPU or 6 vCPU	1 Socket x 4 Cores or 1 Socket x 6 Cores.
Memory	4 GB RAM	
NIC	1 NIC	
Disk Space C:	50 GB	For OS and MSMQ
Disk Space D:	250 GB	For app and SQL - with an option to extend disk up to 2048 MB (2 TB) to support 7 years historical data. It is customer VMware and Storage Administrator's responsibility to ensure sufficient space exists for expansion up to 2 TB on LUN where OmniCenter Virtual Appliance is being deployed.

OmniCenter Base +Virtual Appliance Configuration

Disk Space E:	12 GB	Pagefile
---------------	-------	----------

Minimum Requirements for Deploying Windows 2008 Virtual Appliance

These requirements are common to both Base and Base+ deployments

OmniCenter Windows 2008 Virtual Appliance Minimum Requirements

ESXi Host - Processor	Intel Xeon 5600/3600 Series or higher	ESXi Host should have Intel Xeon 5600/3600 Series (Westmere-EP) or higher. Intel Xeon E5-2440 (SandyBridge family) or higher is highly recommended.
ESXi Host - Power Management	Ensure BIOS setting for power is configured for "Maximum Performance"	
ESXi Host - Hyper threading and SQL licensing	<p>To comply with Microsoft SQL Server 2008 Licensing, physical processor should have one of the following:</p> <ul style="list-style-type: none"> • Four or more cores with hyper threading off • Four or more threads with hyper threading on 	Refer to Microsoft SQL Server 2008 Licensing Guide. Microsoft SQL Server 2008 Licensing Guide

OmniCenter Windows 2008 Virtual Appliance Minimum Requirements

Virtual Machine - Number of sockets and cores	4 vCPU (1 Socket, 4 Cores) or 6 vCPU (1 Socket, 6 Cores)	Match host processor physical cores for best performance. For example, if ESXi host processor has 4 Cores, choose 1 Socket 4 Cores. If host has 6 core processors, choose 1 Socket 6 Cores.
	(Base +) 300-600 cabinets/devices, 30 GHz (8 vCPU x 3.7 GHz)	
Virtual Machine - Hardware Version	<p>Ensure VM is upgraded to latest VM Version. For example,</p> <ul style="list-style-type: none"> • ESXi4 VM hardware version is 7 • ESXi5 VM hardware version is 8 • ESXi5.1 VM hardware version is 9 	To support backward compatibility, Omnicell ships Virtual Appliance with hardware version 7. If you have a newer ESXi version, after deploying the Virtual Appliance, upgrade VM to the latest supported hardware version. This can be done by right-clicking the powered off VM and choosing "Upgrade Virtual Hardware". For more details refer to the VMware Knowledge Base: VMware Knowledge Base
Virtual Machine - Memory	Use Memory Reservation / ESXi 5.1 - Check "Reserve all guest memory (All Locked)"	To ensure OmniCenter VM receives 4 GB RAM allocated to it all the time - to avoid memory starvation during ESXi Host memory overcommit situation.
Virtual Machine - Anti-Virus	Ensure anti-virus exclusions are in place per Omnicell recommendation	Severe performance degradation will occur if anti-virus exclusions are not adhered to.

OmniCenter Windows 2008 Virtual Appliance Minimum Requirements

Storage - IOPS requirements	5,000 IOPS (Input/Output Operations per second) @ 5 ms or less latency	Extensive testing of OmniCenter application shows that with typical workload, average IOPS is approximately 3,000 with occasional spikes up to 15,000.
Storage - Disk Provisioning	Thin or Thick	OmniceLL highly recommends using thick disk provisioning.
Storage - Drive RPM	Minimum 15 K RPM drives	
Storage - RAID configuration	RAID 5 with 12 Disks dedicated to OmniCenter Base + Virtual Appliance	Create a dedicated storage / datastore with RAID 5 (or RAID50) configuration - minimum 12 disks (spindles) recommended. No other VMs should be deployed on this datastore.
VMware - Support	Customer has current production support agreement with VMware	OmniceLL will help triage any performance issue escalation with VMware, but customer should first open ticket with VMware Technical Support.
Customer - IT Support	24/7 IT Support available at customer facility.	Due to mission-critical nature of OmniCenter application and complexity inherent to virtual infrastructure, customer should have appropriate resources (VMware Administrator, Storage Administrator, Windows Administrator, Anti-Virus Administrator) available for troubleshooting any performance issues with deployed OmniCenter Virtual Machine.
OmniceLL - vSuite	OmniceLL vSuite proactive monitoring and remote access.	

OmniCenter Windows 2008 Virtual Appliance Minimum Requirements

OmniceLL - Virtualization Minimum Requirement policy	Customer agrees to comply with Virtualization minimum requirement policy.	Refer to Page 2 of the document http://www.omnicell.com/sitecore/~/_media/Files/PDFs/SVPolicy.pdf
--	---	--

OmniCenter Software Requirements

Software requirements for OmniCenter and Interface Services are listed in this topic.

OmniCenter requires:

- One of the following two operating systems (OS):
 - Microsoft Windows Server 2012 R2 (version 18.5 or higher)
 - Microsoft Windows Server 2008 with Service Pack 2 (version 15.2 or higher)

Interface Services require:

- One of the following three operating systems:
 - Microsoft Windows Server 2012 R2
 - Microsoft Windows Server 2008 with Service Pack 2
 - Microsoft Windows Server 2003 with Service Pack 2
- IIS 5.0, 6.0, or 7.0

Medication Label Printer Specifications

The Integrated Medication Label Printer allows nurses to print patient-specific labels during medication issue.

Medication Label Printer Hardware and Software Requirements

Following are the hardware and software requirements for the Medication Label Printer.

- OmniCenter and Color Touch cabinets running Omnicell 16.0 software or higher. Medication labels can be printed only after the upgrade to 16.0 software.
- Medication Label Printer (APS CP 290) installed and enabled. For procedures on how to install the printer, see the *Medication Label Printer Installation Guide (67-2111)*.
- Omnicell 16.0 software or higher
- G4 cabinet consoles—OmniRx or One-, Two-, or Three-cell automated medication dispensing cabinets.
- Windows 7 OS or Windows XP OS
- Medication labels purchased from Omnicell. One medication label roll is provided in the kit. Additional label rolls must be purchased separately from Omnicell.
- SafetyStock
 - Confirm Med option

- Include bar code on label option
- 2D scanner if medication bar codes are 2D

About the Medication Label Printer Labels

The use of labels supplied by Omnicell is required. Customer deviations from Omnicell product specifications will void Support Service terms.

- The labels are custom-sized to support a printer cutter which cuts the labels between prints to provide a superior user experience. The label adhesive is also FDA Title 21, 60°F–75°F, Humidity: 30%–60% Relative Humidity.
- Avoid direct or indirect exposure to sun light.
- Each roll contains the manufacturer's beyond-use date. Label quality is not guaranteed when storage conditions are not met or after beyond-use date.

Managing Label Inventory

- Labels are ordered using the Omnicell spare parts process. The labels are ordered in boxes of 6 rolls per box. The orders are processed by sending an email request to orders@omnicell.com.
- When ordering labels, consider label usage and label beyond-use date. Allow up to 2 weeks for order processing. Omnicell recommends that a 30-day label supply be kept on hand.

SATO and HP Laserjet Printer Part Numbers

These specifications are available in Agile

Part Number	Printer
70-0161	SATO CL408NX Printer
70-0156	SATO M84 Pro Thermal Printer
70-0167 (P3005DN manufacturer PN)	HP LaserJet P3005dn
70-0167 (P3015DN manufacturer PN)	HP LaserJet Enterprise P3015dn

SATO CL408NX Printer Specifications

This printer has replaced the SATO M84PRO.

Description	Specifications
Power	Universal auto-ranging power supply: 100-240 VAC, 50/60 Hz Energy Star compliant
Dimensions	10.67" (27.1 cm) W, 17.99" (45.7 cm) D, 12.63" (32.1 cm) H
Weight	33.0 lb (15.1 kg)
Agency Approvals	cMETus, CE marking, FCC, NEMKO GS, ICES-003, NMB-003, KC, CCC, S-mark,
Linear Bar Codes	Code 39, Code 93, Code 128, CODABAR (NW7), EAN8/13, GS1-Databar™, GS1-128(UCC/EAN128), Interleaved 2/5, Industrial 2/5, JAN8/13, Matrix 2/5, MS1, Bookland, Postnet™, UPC-A/E2D
2D Symbologies	PDF417, Micro PDF, Maxi Code, GS1 Data Matrix, QR Code, Micro QR Code and Composite SymbologiesEnvironmentOperating32

Table 12: Printer Consumables

Part Number	Description
70-6029	Label, SATO/ALLEGRO, 2.5" x 1", 6" OD (white)
70-6023	Label, SATO 4" x 1", Perf, Roll (white)
70-6078	Label, SATO 4" x 2", Perf, Roll (white)
OPF-OPT-001	White labels for all other OptiFlex items (case)
OPF-OPT-002	White labels for all other OptiFlex items (roll)

Codonics Safe Label System (SLS) 500i Specifications

The integration of the Omnicell Anesthesia Workstation with the SLS provides a streamlined workflow for anesthesiologists and CRNAs.

Description	Specifications
System	Integrated touch screen computer, 2D bar code scanner, color inkjet printer, audio feedback and network capable (Ethernet standard, Wi-Fi optional)
Power	Universal Input: 100-240 VAC, 50/60 Hz
Dimensions	10.43" (26.5 cm) W, 15.67" (39.8 cm) D, 16.5" (41.9 cm) H
Regulatory	FDA cleared to market per 510(k) K101439, Class II MDD CE, GMP/QSR, ISO13485: 2003 Safety IEC/EN 60601-1 and EMC/EMI (EN 55011(A) and EN 60602-2-3 for Healthcare Facilities
Readable Bar Codes	Code 128, GS1-128, Data Matrix, UPC-A, UPC-E, EAN-13, EAN-8, GS1 DataBar Family, Interleaved 2 of 5, ITF-14, Code 39, Code 32, ISBT 128, QR Code
Writable Bar Codes	Data Matrix, EAN-13/UPC-A

Omnicell Cabinet Space Requirements

Cabinet storage capacity is directly proportionate to the square footage of floor space required for each column. Clearance required for pharmacy drawers is equal to clearance required for supply doors. This topic contains standard cabinet specifications. It includes line item capacity and dimensions.

See "[Omnicell Cabinet Drawings](#)" for graphic presentation of measurements. Specifications for cabinet modules are found in "[Omnicell Cabinet Module Specifications](#)". Drawer Specifications are in "[Omnicell Pharmacy Drawer Module Specifications](#)".



Dimensions may vary slightly in size, due to manufacturing variances. Configurator dimensions may be slightly different to allow for variations.

Width includes screw heads on sides of cabinet. Clearance should be added to facilitate moving the cabinets in and out from the wall. Clearance is also needed for modules mounted on the side of the unit—such as the external return bin (ERB) or SafetyStock scanner. Depth includes the door or drawer handle. Clearances are provided when the door/drawer is open. User access may require additional clearance.

Allow 4" (10.16 cm) clearance around each Omnicell cabinet (from the wall and other cabinets) for adequate ventilation.

Some cabinets are used by Omnicell Supply Specialty and SecureVault. Their part numbers are identified as *OPTlxxx* and *xxxxxSV* respectively.

The images in this topic display sample cabinet configurations. Actual configurations and modules may be customized by the hospital. Cabinet weight will vary depending on the configuration.



Estimated maximum weight for a cabinet shelf is 30 lb (13.61 kg).

Cabinet Width With External Return Bin

If an external return bin (ERB) is attached to a cabinet, extend the width by both the depth of the bin (8.25"/20.96 cm) and an additional 6.6" (16.76 cm) to allow the ERB door to open fully (14.85"/37.72 cm total). This is the minimum space required to allow the bin to open fully. Add additional space as desired for convenient access.

Cabinet	Specifications		Metric
One-cell Color Touch G4	Model #:	SDA-FRM-001, MDA-FRM-001, OPF-FRM-001	
		(medical electrical equipment)	
	Item capacity:	96 to 1744	
		(8 items per shelf, max. 12 shelves or 18 drawers/2 shelves)	
	W x H x D:	26.75" x 77.56" x 24.47"	69.1 x 196.90 x 62.5 cm
	Min. width with ERB	41.60"	121.92 cm
	Clearance:	48" depth to include door swing	105.67 cm
	Screen height:	56"	142.24 cm
	Screen size:	12.1" Color Touch	30.74 cm
	Weight:	500 lb empty; varies by configuration	226.80 kg
	Shelf (W x L)	22.75" x 21-22"	59.79 x 53.34-55.88 cm
	(minimum spacing)	3.25" (between light bars)	8.26 cm

Cabinet	Specifications		Metric
		4.5" (between shelves)	11.43 cm

Cabinet	Specifications		Metric
One-cell auxiliary	Model #:	OX104, OPTIX1, OX104SV	
(Pharmacy modules can be added)	Item capacity:	104 to 1752	
		(8 items per shelf, max. 13 shelves or 18 drawers/3 shelves)	
	W x H x D:	26.75" x 77.56" x 24.47"	69.1 x 196.90 x 62.5cm
	Min. width with ERB	41.6"	105.67 cm
	Clearance:	48" depth to include door swing	121.92 cm
	Screen height:	N/A	
	Weight:	500 lb empty; varies by configuration	226.80 kg
	Shelf (W x L):	22.75" x 21-22"	59.79 x 53.34- 55.88 cm
	(minimum spacing)	3.25" (between light bars)	8.26 cm
		4.5" (between shelves)	11.43 cm

Cabinet	Specifications		Metric
Two-cell Color Touch G4	Model #:	SDA-FRM-002, MDA-FRM-002, OPF-FRM-002	
		(medical electrical equipment)	
	Item capacity:	216 to 3128	
		(8 items per shelf, max. 27 shelves or 32 drawers/7 shelves)	
	W x H x D:	51.5" x 77.56" x 24.47"	131.9 x 196.90 x 62.5 cm
	Min. width with ERB	66.35"	168.53 cm
	Clearance:	48" depth to include door swing	121.92 cm
	Space req.:	17.33 sq. ft. with door open	1.61 sq. m
	Screen height:	56"	142.24 cm
	Screen size:	12.1" Color Touch	30.74 cm
	Weight:	750 lb empty; varies by configuration	340.19 kg
	Shelf (W x L):	22.75" x 21-22"	59.79 x 53.34-55.88 cm

Cabinet	Specifications		Metric
	(minimum spacing)	3.25" (between light bars)	8.26 cm
		4.5" (between shelves)	11.43 cm

Cabinet	Specifications		Metric
Two-cell auxiliary	Model #:	OX224, OPTIX2, OX224SV	
(Pharmacy modules can be added)	Item capacity:	224 to 3136	
		(8 items per shelf, max. 28 shelves or 32 drawers/8 shelves)	
	W x H x D:	51.5" x 77.56" x 24.47"	131.9 x 196.90 x 62.5 cm
	Min. width with ERB	66.35"	168.53 cm
	Clearance:	48" depth to include door swing	121.92 cm
	Screen height:	N/A	
	Weight:	750 lb empty; varies by configuration	340.19 kg
	Shelf (W x L):	22.75 x 21-22"	57.79 x 53.34- 55.88 cm
	(minimum spacing)	3.25" (between light bars)	8.26 cm
		4.5" (between shelves)	11.43 cm

Cabinet	Specifications		Metric
Three-cell Color Touch G4	Model #:	SDA-FRM-003, MDA-FRM-003, OPF-FRM-003	
		(medical electrical equipment)	
	Item capacity:	336 to 5280	
		(8 items/shelf max. 42 shelves or 54 drawers/12 shelves)	
	W x H x D:	76.25" x 77.56" x 24.47"	193.675 x 196.99 x 62.15 cm
	Min. width with ERB	91.1"	121.92 cm
	Clearance:	48" depth to include door swing	231.4 cm
	Screen height:	56"	142.24 cm
	Screen size:	12.1" Color Touch	30.74 cm
	Weight:	1000 lb empty; varies by configuration	453.59 kg
	Shelf (W x L):	22.75" x 21-22"	57.79 x 53.34-55.88 cm
	(minimum spacing)	3.25" (between light bars)	8.26 cm

Cabinet	Specifications		Metric
		4.5" (between shelves)	11.43 cm

Cabinet	Specifications		Metric
Three-cell auxiliary	Model #:	OX344, OPTIX3, OX344SV	
(Pharmacy modules can be added)	Item capacity:	344 to 5288	
		(8 items per shelf, max. 43 shelves or 54 drawers/13 shelves)	
	W x H x D:	76.25" x 77.56" x 24.47"	193.675 x 196.99 x 62.15 cm
	Min. width with ERB	91.1"	231.4 cm
	Clearance:	48" depth to include door swing	121.92 cm
	Screen height:	N/A	
	Weight:	1000 lb empty; varies by configuration	453.59 kg
	Shelf (W x L):	22.75" x 21-22"	57.79 x 53.34 x 55.88 cm
	(minimum spacing)	3.25" (between light bars)	8.26 cm
		4.5" (between shelves)	11.43 cm

Cabinet	Specifications		Metric
Half-cell Color Touch G4	Model #:	MDA-FRM-004	
		(medical electrical equipment)	
	Item capacity:	56 items	
		(8 per shelf, max. 7 shelves) or 80-120 items w/3-drawer carrier.	
	W x H x D:	27.9" x 57.7" x 26.6" with bumpers	70.9 x 146.6 x 67.6 cm
	Clearance:	48" depth to include door swing	121.92 cm
	Work surface height:	45.2"	114.81 cm
	Screen size:	15" Color Touch	38.1 cm
	Weight:	360 lb with med drawers and ERB; varies by configuration	234.96 kg
	Shelf (W x L):	22.75" x 21-22"	57.79 x 53.34-55.88 cm
	(minimum spacing)	3.25" (between light bars)	8.26 cm
		4.5" (between shelves)	11.43 cm

Cabinet	Specifications		Metric
Half-cell auxiliary	Model #:	56AXRX, 56AX	
	Item capacity:	56 (8 items per shelf, max. 7 shelves) or 80-120 w/3 drawer carrier	
	W x H x D:	27.9" x 45" x 26.6"	70.9 x 114.3 x 67.6 cm
	Clearance:	48" depth to include door swing	121.92 cm
	Work surface height:	45"	114.3 cm
	Screen size:	N/A	
	Weight:	360 lb with med drawers and ERB; varies by configuration	226.8 kg
	Shelf (W x L):	22.75" x 21-22"	57.79 x 53.34-55.88 cm
	(minimum spacing)	3.25" (between light bars)	8.26 cm
		4.5" (between shelves)	11.43 cm

Cabinet	Specifications	Metric
Controlled Substance Manager (CSM)	Model # CSM-FRM-001, CSM-FRM-002, CSM-FRM-003	
	Item Capacity: CSM-FRM-001: 104-1752; CSM-FRM-002: 224-3136; CSM-FRM-003: 344-5288	
	W x H x D: CSM-FRM-001: 26.75" x 77.56" x 24.47"; CSM-FRM-002: 51.5" x 77.56" x 24.47"; CSM-FRM-003: 76.25" x 77.56" x 24.47"	CSM-FRM-001: 69.1 x 196.9 x 62.5 cm; CSM-FRM-002: 131.9 x 196.9 x 62.5 cm; CSM-FRM-003: 193.68 x 196.99 x 62.15 cm

Cabinet	Specifications	Metric
	Clearance: CSM-FRM-001, 48" depth to include door swing; (all models)	121.92 cm
	Minimum width with ERB: CSM-FRM-001: 41.6"; CSM-FRM-002: 66.35"; CSM-FRM-003: 91.1"	CSM-FRM-001: 121.92 cm; CSM-FRM-002: 168.53; CSM-FRM-003:121.92
	Weight: CSM-FRM-001: 500 lb empty; CSM-FRM-002: 750 lb empty, CSM-FRM-003: 1000 lb empty (varies by configuration)	CSM-FRM-001: 226.80 kg empty; CSM-FRM-002: 340.19 kg empty; CSM-FRM-003: 453.59 kg empty (varies by configuration)
	Minimum spacing: 3.25" (between light bars) 4.5" (between shelves) (all units)	8.26 cm (between light bars) 11.43 cm (between shelves) (all units)

Cabinet	Specifications		Metric
Supply Mobile Cart G4	Model # (Supply):	SDA-FRM-004	
	Model # (OptiFlex):	OPF-FRM-004	
		(medical electrical equipment)	
	Item capacity:	56 (8 items per shelf, max. 7 shelves) or 80-120 w/3-drawer carrier	
	W x H x D:	27.9" x 57.7" x 26.6"	70.9 x 146.6 x 67.6 cm
	Clearance:	48" depth to include door swing	121.92 cm
	Work surface height:	45.2"	114.3 cm
	Screen size:	15" Color Touch	38.1 cm
	Weight:	207 lb empty; varies by configuration	93.89 kg
	Shelf (W x L):	22.75" x 21-22" (W x D)	57.79 x 53.34-55.88 cm
	(minimum spacing)	3.25" (between light bars)	8.26 cm
	4.5" (between shelves)	11.43 cm	

Cabinet	Specifications		Metric
	Features:		
		Wireless	
		Battery–10 hr.	
		Analog battery gauge on front	
		Cord loop	
		Medical grade power supply	
	Optional modules:		
		Pull-out shelf	
		Supply drawer	
		Card reader	
		BioMetric	

Cabinet	Specifications		Metric
OmniRx Color Touch G4	Model #:	MDA-FRM-005	
		(medical electrical equipment)	
	Item capacity:	13 drawers (typically 350-450 medications)	
		3 drawers (typically 80-120 medications)	
	W x H x D:	27.9" x 57.7" x 26.9" with bumpers	70.9 x 146.6 x 68.4 cm
	Min. width with ERB	42.75"	111.76 cm
	Clearance:	44" depth includes drawer extension	108.59 cm
	Work surface height:	45.2"	114.81 cm
	Screen size:	15" Color Touch	38.1 cm
	Weight:	518 lb empty; varies by configuration	234.96 kg

Cabinet	Specifications		Metric
OmniRx auxiliary	Model #:	RXAX (medical electrical equipment)	
	Item capacity:	13 drawers (typically 350-450 medications)	
		3 drawers (typically 80-120 medications)	
	W x H x D:	27.9" x 45" x 26.9" with bumpers	70.9 x 115.57 x 68.4 cm
	Min. width with ERB	42.75"	108.59 cm
	Clearance:	44" depth includes drawer extension	111.76 cm
	Work surface height:	45"	114.3 cm
	Screen size:	N/A	
	Weight:	500 lb empty; varies by configuration	226.8 kg
	Model #:	TTCT, ANTT	

Cabinet	Specifications		Metric
OmniRx TT/Anesthesia TT G4	Model #:	MDA-FRM-006, ANT-FRM-002	
		(medical electrical equipment)	
	Item capacity:	3 drawers (typically 80-120 medications)	
	W x H x D:	26" x 27.5" x 23.75" (without bumper) 26.9" (with bumper)	66.04 x 69.85 x 60.33 (without bumper) 68.33 cm (with bumper)
	Clearance:	44" depth includes drawer extension	111.76 cm
	Work surface height:	15.7"	39.88 cm
	Screen size:	15" Color Touch	38.1 cm
	Weight:	133 lb without drawers	52.16 kg

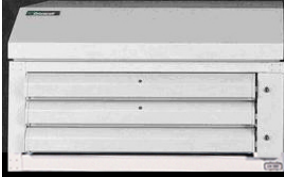
Cabinet	Specifications		Metric
OmniTT auxiliary	Model #:	TTAX	
	Item capacity:	3 drawers (typically 80-120 medications)	
	W x H x D:	26.3" x 15.6" x 27" with bumpers	66.8 x 39.6 x 65.6 cm
	Clearance:	44" depth includes drawer extension	111.76 cm
	Work surface height:	15.5"	39.37 cm
	Screen size:	N/A	
	Weight:	133 lb without drawers	52.16 kg

Cabinet	Specifications		Metric
 <p>Anesthesia Workstation G4</p>	Model #:	ANT-FRM-001	
		(medical electrical equipment)	
	Item capacity:	13 drawers (typically 350-450 items)	
	W x H x D:	50" x 63.5" x 30"	127 x 161.3 x 76.2 cm
		W=64" with user interface arm extended	W=162.6 cm with arm extended
	With ERB:	Add 6.6" to width (W)	16.77 cm
	With fold-out shelf:	Add 15" to width (W)	38.1 cm
	With trash or Sharps Bin-Single Use:	Add 7" to width (W)	17.78 cm
	Clearance:	46" depth includes drawer extension	116.84 cm
	Work surface height:	43"	109.22 cm
Keyboard height:	Variable: 31" to 48.5"	78.74 cm to 123.19 cm	
Screen size:	15" Color Touch	38.1 cm	

Cabinet	Specifications		Metric
	Weight:	560 lb empty; varies by configuration	254.01 kg
	Accessories:		
		Trellis	
		Tape dispenser	
		Gooseneck light	
		Printer	
		Accessory mounting kit	
		iPod compatible speakers	
		Sharps bin - Single use (13.75" x 16" x 7")	34.93 x 40.64 x 17.78 cm
		Anesthesia supply drawers	
		Power strip	
		Options:	
		Waste container (13.75" x 13.5" x 7")	34.93 x 34.29 x 17.78 cm
		Tilt bin organizer	
		IV Pole	



Cabinet	Specifications		Metric
		Chart holder	
		External Return Bin (ERB) (13.25" x 13" x 8.25") (add 6.6" min for door)	33.66 x 33.02 x 20.96 cm (16.77 cm)
		Wireless (802.11 g)	
		Touch and Go/Magnetic Card Reader	
		Fold-out shelf (15" x 18")	38.1 cm x 45.72 cm
		Pharmacy drawers	
		50 ft. cable for ERB	15.24 m
		Emergency breakaway panel	



Cabinet	Specifications		Metric
Mobile Cart - Savvy	Model #:	MMM-FRM-001	
	Item capacity:	Up to 12 locking drawers	
	W x H x D:	22" x H (variable) x 22-32"	55.8 x (variable) x 55.8 - 81.28 cm
		Width: 22"	55.8 cm
		Height: 52" - 64" including monitor	132.08 - 162.56 cm
		Depth: 32" with keyboard fully extended	81.28 cm
	Work surface area:	17" x 12"	43.18 x 30.48 cm
	Work surface height:	33" - 45" (adjustable)	83.82 - 114.30 cm
	Base:	16" x 16"	40.64 x 40.64 cm
	Weight:	100 - 165 lb	45.36 -74.85 kg
	Drawer sizes	9" L x 4" W x 3" D	22.86 x 10.16 x 7.62 cm
		9" L x 4" W x 6" D	22.86 x 10.16 x 15.24 cm

Omnicell Cabinet Module Specifications



This section lists Omnicell cabinet module specifications. It includes line item capacity and dimensions.

Table 13: Module Specifications



Module	Specifications		Metric
9-drawer pharmacy carrier	Model #:	OSRXU	
	Item capacity:	9 drawers	
	W x H x D:	1 zone / 5 shelves	
	Weight:	200 lb (w/o drawers)	90.72 kg
3-drawer pharmacy carrier (shown in a cabinet and a half cell)	Model #:	OS 3DRXU	
	Item capacity:	3 drawers	
	W x H x D:	1 zone (w/o drawers)	
	Weight:	100 lb	45.36 kg



OmniDispenser (shown with 3-drawer carrier)	Model #:	ODMPlus3 (includes 3-drawer pharmacy carrier);	
		ODMTall (includes half-door, up to 6 shelves);	
		ODMRx (placed in OmniRx)	
	Item capacity:	Up to 45 small and 24 large cassette dispensers [all]	
	W x H x D:	1 zone / 3 shelves / 6 drawers [by model order]	
	Weight:	50 lb (w/o rails) [all]	22.68 kg
External return bin (ERB)	Model #:	OERB1	
	Item capacity:	N/A	
	W x H x D:	13.25" x 13" x 8.25"	33.66 x 33.02 x 20.96 cm
	Clearance:	14.85" minimum depth with door open.	37.72 cm
	Weight:	17 lb	7 kg
	Placement:	On wall or side of cabinet	

	Note:	No minimum height for placement. The ERB can also be mounted on half-cell modules; the clearance requirement is the same as on 1-, 2, and 3-cell modules. The part # for the Installation Kit is 20-6100		
FlexLock (installed on refrigerator)	Model #: 1.0	OCFLTCK		
	Item capacity:	N/A		
	W x H x D:	5.5" x 5.5" x 12.4"	14.0 x 14.0 x 31.5 cm	
	Clearance:	Refrigerator specs vary; allow 2" side clearance for key access and for 2" rear access for cable.	add 5.08 cm; side and rear clearance	
	Weight:	8 lb	3.6 kg	
	Note:	See "Refrigeration Options" .		
OmniTrack	Model #:	OT32		
	Item capacity:	32		
	W x H x D:	1 shelf position		
	Weight:	4 lb	1.8 kg	
Pull-out shelf	Model #:	PS1		

	Item capacity:	8		
	W x H x D:	1 shelf position (22.75" x 23" x 4.63")	57.79 x 58.42 x 11.76 cm	
	Weight:	19 lb	8.6 kg	
Supply drawer	Model #:	OSD24		
	# of bins:	24 maximum		
	Bin W x H x D:	2" x 4.25" x 3.75"	5.08 x 10.8 x 9.53 cm	
	Drawer W x H x D:	22" x 21.5" x 4" (1 shelf position)	55.88 x 54.61 x 10.16 cm	
	Weight:	30 lb	13.6 kg	

Catheter rack	Model #:	OCR48		
	Item capacity:	48 (4 rails x 12 items each)		
	W x H x D:	2-3 zones		
	Weight:	50 lb	22.6 kg	
	Note:	Catheter rack is placed in the top zone.		
Suture rack	Model #:	OCR24		
	Item capacity:	24 (3 racks x 8 items each)		
		2 shelf positions		
	Weight:	71 lb	32.2 kg	

<p>Anesthesia Workstation (AWS) Tilt Bins - 4 bins</p>	<p>Model #:</p>	<p>ANT-OPT-008</p>	
	<p>Dimensions:</p>	<p>23.63"W x 8.13" H x 6.63" D</p>	<p>60.02 x 20.65 x 16.84 cm</p>
<p>Anesthesia Workstation (AWS) Tilt Bins -5 bins</p>	<p>Model #:</p>	<p>ANT-OPT-009</p>	
	<p>Dimensions:</p>	<p>23.63 "W x 6.5" H x 5.25" D</p>	<p>60.02 x 16.51 x 13.34 cm</p>

Anesthesia Workstation (AWS) Tilt bins - 6 bins	Model #:	ANT-OPT-010	
	Dimensions:	23.63 "W x 4.5" H x 3.63" D	60.02 x 11.43 x 9.22 cm
Corded bar code scanner	Model #:	Symbol LS4208	
(Shown with cradle and goose neck)	Extra Spacing:	None needed for Anesthesia Workstation, OmniRx, OmniTT or Anesthesia TT	
		Additional 6" needed for one-, two-, three-cell cabinets using gooseneck	Add 15.24 cm
	Programming:	Varies by application	
	Applications:	Item Scan (for Anesthesia Workstation, TT), SafetyStock (for cabinets)	

Cordless bar code scanner	Model #:	Symbol P370		
	Range:	100 feet	30.48 m	
	Programming:	Varies by application		
	Applications:	OmniScanner, OptiFlex, WorkflowRx, and Implant Tracking		
Wireless bar code scanner	Model #:	Symbol MT2070		
	Range:	300 feet	91.44 m	
	Programming:	Varies by application		
	Applications:	OmniScanner, OptiFlex, WorkflowRx, and Implant Tracking, CSM		
Cordless bar code scanner	Model #:	Code Reader 2500		
	Range:	300 feet	91.44 m	
	Applications:	Carts		
	Connection:	Bluetooth 2.0 + EDR, Class1 Radio, (2.4GHz ~ 2.4835GHz frequency)		

Cordless bar code scanner	Model #:	Code Reader 3500		
	Range:	300 feet	91.44 m	
	Applications:	WorkflowRx		
	Connection:	Bluetooth 2.0 + EDR, Class 1 Radio, (2.4GHz ~ 2.4835GHz frequency)		
2D Scanner	Model #:	Symbol DS6708 Imager		
	Applications:	Item Scan, SafetyStock		

<p>Touch and Go (Bio ID)</p>	<p>Refer to the <i>Touch and Go Technical Guide</i> (P/N 67-3014) for system requirements.</p>		
<div data-bbox="159 464 604 835" data-label="Image"> </div> <p data-bbox="142 856 651 890">PC Box (left) and AWS housing (G3) and G4</p>	<p data-bbox="686 424 1279 594">Note: There are various housings for Touch and Go. The finger pad is used for Touch and Go. There is also a slot for reading magnetic or bar code cards. See card readers in the following table row.</p> <p data-bbox="686 745 1252 814">Available for Color Touch cabinets; not available for Omnicell Supply Specialty</p>		
<p>Magnetic and bar code card readers</p>	<p>Refer to the <i>Omnicell/Omicell Supply Specialty Card Reader Installation and Configuration Guide</i> (P/N 67-2006) for system requirements.</p>		
<div data-bbox="142 1255 488 1520" data-label="Image"> </div> <p data-bbox="142 1541 634 1610">Housing for half-cell, OmniTT, OmniRx G3 on left, G4 on right</p>	<p data-bbox="686 1169 1268 1304">Note: The card reader uses the same housing as Touch and Go. These modules can be ordered separately or together. The electronics in the housing determine which modules are functional.</p> <p data-bbox="686 1362 1224 1432">Omnicell Supply Specialty only uses magnetic card readers.</p> <p data-bbox="686 1509 1252 1610">Readers can have two read heights: 0.4 and 0.49 inches. See "Appendix A: Read Height" to determine which height to use.</p>	<p data-bbox="1313 1493 1370 1627">1.02 and 1.24 cm</p>	

FlexLock 2.0

FlexLock offers security for supplies or refrigerated medications. It can be attached to a refrigerator storing thermally sensitive medications or to a supply cabinet. It is then cabled to an Omnicell cabinet. A maximum of two FlexLocks can be attached to one Omnicell cabinet. For optimum use, the FlexLock should be located as close to the OmniSupplier as possible. The Color Touch screen can display the status of the FlexLock (Open/Closed, Locked/Unlocked). FlexLock 2.0 builds on the previous FlexLock system to provide the software and hardware enhancements described here. FlexLock 2.0 is only compatible with G4 cabinets.

FlexLock 2.0 Software Enhancements

- Decimal point display of temperature to tenths
- New column in temperature report indicates FlexLock version
- Default temperature reading interval of 15 minutes
- New report to show past calibration entries
- Calibration entry screen
- Calibration entry report
- Three calibration process types to choose from:
 - Ice Point
 - Traceable
 - Other

FlexLock 2.0 Hardware Enhancements

- Brushed stainless steel casing
- Larger front bracket for stronger bonding to refrigerator door
- New adjustments for simpler installation
- New printed circuit board design to support new functions
- New temperature monitoring hardware with a submersible probe

System Requirements

For FlexLock 2.0 to run properly on an Omnicell system, the following requirements must be met:

Physical Requirements

- A refrigerator or cabinet that fits the FlexLock template and meets regulatory standards
- Spacing
 - Length—12"
 - Height—6"
 - Depth—6" (3" is acceptable if the refrigerator or cabinet can be moved to access the override lock)
- G4 cabinet or G3 cabinet with a G4 console upgrade

Software Requirements

For full functionality that facilitates compliance with CDC guidelines, Omnicell 20.0 software or higher is required. Omnicell software versions below 17.5 are not supported, Software versions 17.5 through 19.5 can be used, but with the following limited functionality:

- Probe cannot be calibrated
- Temperature reading on screen and in reports are integer only; no decimal resolution
- No calibration report in OmniCenter reports

TempCheck System Requirements

Before a FlexLock can be used, it must be installed on a refrigerator or cabinet and configured at the OmniCenter and an Omnicell cabinet. The FlexLock can be cabled to the following Omnicell products:

- OmniCenter and Color Touch cabinets running Omnicell 20.0 software or higher
- Email application enabled at Omnicenter (SMTP server provided by the hospital IT department)
- FlexLock installed and configured with FlexLock assembly # 14-7080 and manufacturing assembly kit # 20-6023
- Retrofits for an existing FlexLock with Tempcheck kit # 20-6134
- Cable kit # 20-6108 for upgrading tall cabinets to G4

Tools Required for FlexLock Installation

- Cam lock keys #2202 and #2232 (FlexLock)
- Cam lock keys #2202 and #2204 (ERB)
- ESD wrist strap
- T-10 torx driver
- T-8 torx driver
- 1/4" hex driver (with various bit sizes)
- 5/16" nut driver
- Screwdriver (for vertical alignment)
- Needle-nose pliers (helpful with peeling adhesive cover)
- Standard Phillips screwdriver

Refrigeration Options

Refrigerators are used with FlexLock or inside cabinets. They must be purchased from a third party. A half-size refrigerator can take up to two zones in a cabinet, using two shelf positions above it (up to 46 inches). Using a dorm-size refrigerator inside a cabinet takes up only one zone.



Dorm-style refrigerators are not CDC-compliant.

Special orders for refrigerator-ready cabinet (with vents for heat dissipation) have a six-week lead time. The following tables list compatible free-standing refrigerators (full size and compact).

Full-Size Refrigerators

Manufacturer	Model	Exterior Dimensions W x D x H (metric)	Internal Volume; cu ft. (metric)	Notes
GE	GTS18GBSW	28.0" x 32.38" x 67.38" (71.12 x 82.25 x 171.15 cm)	18.2 cu. ft. (52 cu. m)	

Manufacturer	Model	Exterior Dimensions W x D x H (metric)	Internal Volume; cu ft. (metric)	Notes
Inglis	IT4KXSQ	28.0" x 31.0" x 62.9" (71.12 x 78.74 x 159.77 cm)	14.4 cu. ft. (0.41 cu. m)	
Kenmore	27422	28.0" x 31.0" x 59.0" (71.12 x 78.74 x 149.86 cm)	14.1 cu. ft. (0.40 cu. m)	
Kenmore	26422	28.0" x 28.5" x 59" (71.12 x 72.39 x 149.86 cm)	14 cu. ft. (0.40 cu. m)	
Kenmore	27042	33.3" x 18.6" x 19.5" (84.15 x 47.14 x 49.53 cm)	20.6 cu. ft. (0.58 cu. m)	
Kenmore	26082	32.0" x 28.50" x 70.0" (81.28 x 72.39 x 177.80 cm)	21 cu. ft. (0.59 cu. m)	
Panasonic	MPR-721-PA	30.30" x 32.70" x 77.0" (77.0 x 83.0 x 196 cm)	24.2 cu. ft. (0.69 cu. m)	Medical grade vaccine refrig.
Whirlpool	ER8AHMXRQ	28.0" x 31.0" x 68.0" (172.72 x 71.12 x 78.74 cm)	17.6 cu. ft. (0.50 cu. m)	
Whirlpool	ER6AHKXSQ	28.40" x 30.60" x 65.5" (166.37 x 71.6 x 77.62 cm)	15.9 cubic ft. (0.45 cubic m)	
Whirlpool	GR2FHMPQ	29.50" x 31.50" x 66.5" (168.91 x 74.93 x 80.01 cm)	21.7 cubic ft. (0.06 cubic m)	

Table 14: Small Refrigerators

Manufacturer	Model	Exterior Dimensions; W x D x H (metric)	Internal Volume; cu ft. (metric)	Notes
Accucold by Summit Appliance	FFAR24LMED5	17.75" x 17.63" x 19.75" (45.08 x 44.78 x 50.17 cm)	1.7 cu. ft. (0.05 cu. m)	Medical grade
Accucold by Summit Appliance	FF511L7MED	19.25" x 21.38" x 33.5" (48.90 x 54.31 x 85.09 cm)	4.1 cu. ft. (0.12 cu. m)	Medical grade
Accucold by Summit Appliance	FF7LBIMEDADA	23.63" x 23.5" x 32.0" (67.64 x 59.69 x 81.28)	5.5 cu. ft. (0.16 cu. m)	Medical grade
Accucold by Summit Appliance	FF590SSHHMED	23.63" x 24.25" x 34.13" (67.64 x 61.56 x 86.69 cm)	5.7 cu. ft. (0.16 cu. m)	Medical grade
American BioTech Supply	ABT-UCFS-0204G	17.75 " x 19.5" x 29.0" (45.09 x 49.53 x 73.66 cm)	2.5 cu. ft. (0.07 cu. m)	Medical grade; OmniceII/Pyxis compliant
American BioTech Supply	ABT-UCFS-0504W	21.5" x 22.5" x 33.5" (54.61 x 64.80 x 85.09 cm)	4.6 cu. ft. (0.13 cu. m)	Medical grade; OmniceII/Pyxis compliant
American BioTech Supply	ABT-UCFS-0504G	23.75" x 24.5" x 32.2" (60.33 x 62.23 x 81.79 cm)	5.2 cu. ft. (0.15 cu. m)	Medical grade; OmniceII/Pyxis compliant
American BioTech Supply	ABT-UCBI-0404SS	23.75" x 24.5" x 33.4" (60.33 x 62.23 x 84.84 cm)	4.5 cu. ft. (0.13 cu. m)	Medical grade; OmniceII/Pyxis compliant
Danby	DAR044A4BDD	20.6" x 21.0" x 32.6" (52.6 x 53.0 x 83.1 cm)	4.4 cu. ft. (0.12 cu. m)	

Manufacturer	Model	Exterior Dimensions; W x D x H (metric)	Internal Volume; cu ft. (metric)	Notes
Follett	REF-1	18.6" x 24.0" x 17.75" (47.0 x 61.0 x 45.0 cm)	1 cu. ft. (0.03 cu. m)	Medical grade; priority/most commonly used
Follett	REF-4P-xx-xx	23.8" x 27.0" x 31.4" (60.3 x 68.5 x 79.7 cm)	3.9 cu. ft. (0.11 cu. m)	Medical grade; priority/most commonly used
Follett	REF-5P-00-00	23.75" x 25.62" x 34.0" (60.3 x 65.1 x 86.4 cm)	4.5 cu. ft. (0.13 cu. m)	Medical grade; priority/most commonly used
Helmer	SLR105	19.50" x 22.0" x 19.75" (49.53 x 55.88 x 50.17 cm)	5 cu. ft. (0.14. cu m)	Medical grade; priority/most commonly used
Helmer	SLR104-ADA	19.50" x 22.0" x 17.75" (49.53 x 55.88 x 45.09 cm)	4 cu. ft. (0.11 cu. m)	Medical grade; priority/most commonly used
Helmer	HLR105	19.50" x 22.0" x 19.75" (49.53 x 55.88 x 50.17 cm)	5 cu. ft. (0.14. cu m)	Medical grade; priority/most commonly used
Helmer	HLR104-ADA	19.50" x 22.0" x 17.75" (49.53 x 55.88 x 45.09 cm)	4 cu. ft. (0.11 cu. m)	Medical grade; priority/most commonly used
Helmer	iLR105	19.50" x 22.0" x 19.75" (49.53 x 55.88 x 50.17 cm)	5 cu. ft. (0.14 cu. m)	Medical grade; priority/most commonly used
Helmer	iLR104-AD	19.50" x 22.0" x 17.75" (49.53 x 55.88 x 45.09 cm)	5 cu. ft. (0.14 cu. m)	Medical grade; priority/most commonly used

Manufacturer	Model	Exterior Dimensions; W x D x H (metric)	Internal Volume; cu ft. (metric)	Notes
Migali	GU1R-ADA	23.78" x 25.52" x 32.23" (60.40 x 64.82 x 81.86 cm)	4.3 cu. ft. (0.12 cu. m)	Medical grade; OmniceII/Pyxis compliant
Nor-Lake	NSLR051WMW0	27.0" x 25.0" x 35.25 (68.6 x 63.5 x 89.5 cm)	5.1 cu. ft. (0.14 cu. m)	Medical grade
Nor-Lake	NSLR041WMW/0M	23.9" x 25.0" x 35.25" (60.6 x 63.5 x 58.1 cm)	4.6 cu. ft. (0.13 cu. m)	Medical grade
Nor-Lake	NSLR051WMW0M	27.0" x 25.0" x 35.25 (68.6 x 49.5 x 58.1 cm)	5.4 cu. ft. (0.15 cu. m)	Medical grade
Sanyo	SR-L6111W	23.80" x 22.50" x 34.5" (60.0 x 64.80 x 87.6 cm)	6.1 cu. ft. (0.17 cu. m)	Medical grade; priority/most commonly used
Thermo Scientific	MR05PA-SEEE-TS	24.0" x 24.10" x 34.70" (61 x 61.3 x 86.7 cm)	5.4 cu. ft. (0.15 cu. m)	Priority/most commonly used

The following two diagrams show the maximum cabinet internal dimensions for a refrigerator. Allow sufficient space around the unit for ventilation, installation, and refrigerator door-swing clearance. Some refrigerators have hinges that allow the door to swing within the width of the refrigerator. Others may swing wider than the refrigerator width.

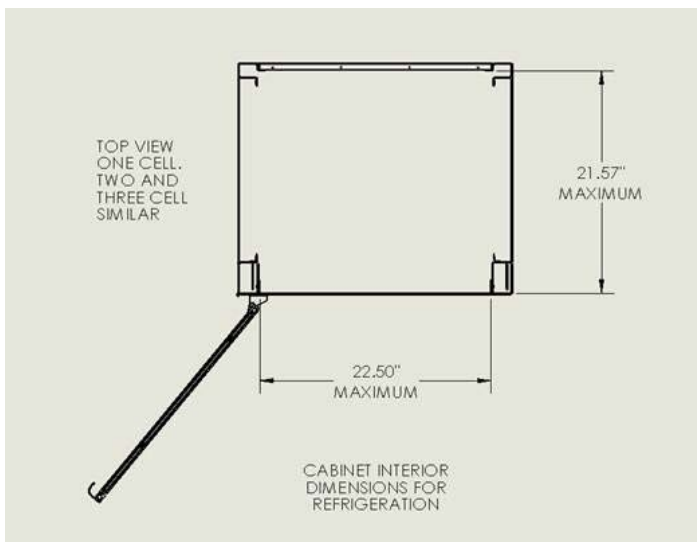
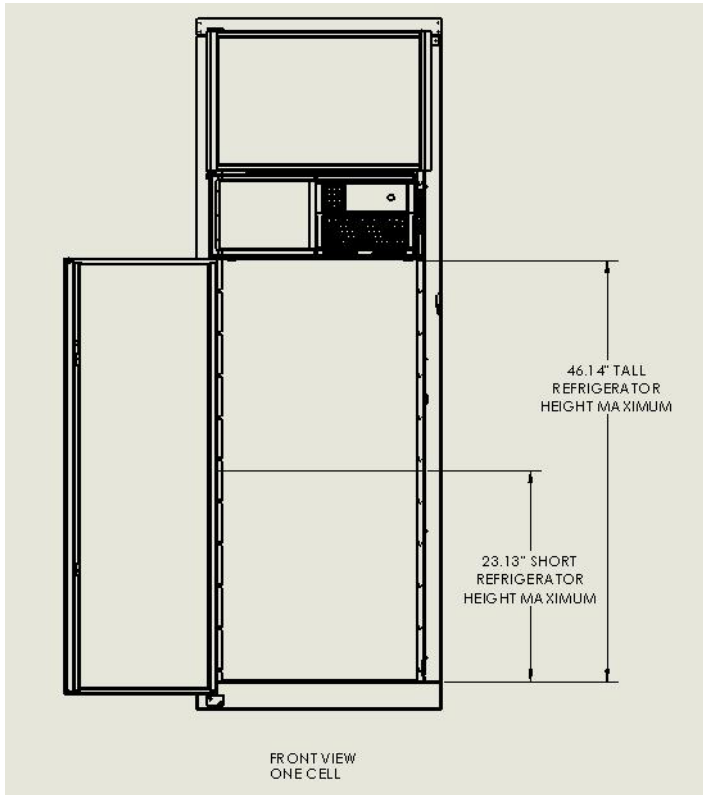

These diagrams allow for either a small "dorm" refrigerator in the bottom zone or a taller refrigerator that extends into the zone above as well.



Dorm-style refrigerators are not CDC-compliant.

Refrigerators dissipate heat as part of the cooling cycle. Ventilation must be provided to allow the internally generated heat to be dissipated.

Customers must order the tall cabinets in advance if they want to put a refrigerator inside. The frames are manufactured from scratch with special panels that have ventilation holes. These panels are riveted in place as the frames are manufactured and painted.



Refrigerators are allowed in the first cell and the second cell, but not in the third cell of a 3-cell cabinet.

Power consumption and dissipation for small refrigerators ranges from approximately **99-135 BTU/hr** and from **253-345 KWhr/year**. Note that for proper operation, refrigerators cycle the compressors on and off. Omnicell does not recommend using dorm-style refrigerators for critical refrigeration needs.



Use caution with vaccines as the temperature ranges must be strictly controlled, monitored, and recorded. Low cost, non-medical grade refrigerators may not provide adequate temperature control for these substances.

Omnicell Pharmacy Drawer Module Specifications

Drawers fit into 1-, 2-, 3-cell cabinets, OmniRx, OmniTT, and in Anesthesia cabinets. Pharmacy carriers can also be used with 1-, 2-, 3-cell, and half-cell cabinets.

The combination of an Omnicell cabinet with Omnicell pharmacy modules allows storage and dispensing of supplies and drugs in unit dose forms of:

- Oral solids
- Oral liquids
- IV syringes
- Ampoules
- Vials
- Bulk stock

In the measurements (W x H x D), H is the height of the drawer or bin from top to bottom, and D is the distance from the front to the back of the drawer or bin.



High Security FlexBin Single-dose Drawer Specifications

The FlexBin Single-dose Drawer provides a high level of security for medications. With this drawer, access to medications is restricted to the item and quantity chosen by the user. There is no need to confirm the remaining quantity or conduct end-of-shift counts, which results in fewer discrepancies.

Key features of the FlexBin single-dose drawer are

- Single-deep drawer
- Three bin sizes
- Bins can be used for single-dose
- Three drawer configurations: 96 small bins, 48 medium bins, and 48 small/large combo
- Capacity of up to 96 doses

Table 15: High Security FlexBin Drawer Configurations

Drawer	Specifications (metric)		Security	Best Use
	Model #:	MDA-DRW-003	High	Ampoules
	# of Bins:	96		
	Bin W x H x D:	1 wide/ 2"x 1" x 1.4" (5.08 x 2.54 x 3.56 cm)		
	Drawer W x H x D:	21.5" x 2.5" x 22.5" (54.61 x 6.35 x 57.15 cm)		
	Weight:	22.5 lb [empty] (10.21 kg)		
		Comes with or without lights		
	Model #:	MDA-DRW-002	High	Syringes and ampoules
	# of Bins:	48		
	Bin W x H x D:	3 wide/ 6.9" x 1" x 1.5" (17.53 x 2.54 x 3.81 cm)		

Drawer	Specifications (metric)		Security	Best Use
	Bin W x H x D:	1 wide/ 2" x 1" x 1.4" (5.08 x 2.54 x 3.56 cm)		
	Drawer W x H x D:	21.5" x 2.5" x 22.5" (54.61 x 6.35 x 57.15 cm)		
	Weight:	21.5 lb [empty] (9.75 kg)		
		Comes with or without lights		
FlexBin 2222 Single dose	Model #:	MDA-DRW-001	High	Vials
	# of Bins:	48		
	Bin W x H x D:	4.4" x 1" x 1.5" (11.18 x 2.54 x 3.81 cm)		
	Drawer W x H x D:	21.5" x 2.5" x 22.5" (54.61 x 6.35 x 57.15 cm)		
	Weight:	21 lb [empty] (9.53 kg)		
		Comes with or without lights		

High Security Locking Bin Drawer Specifications



Locking bins, suitable for controlled substances, provide a high level of security by restricting access to one pre-selected medication at a time. The tamper-proof metal lids of each bin and audio alerts provide additional security.



Omicell guiding light technology guides users to the drawer and to the appropriate preselected bin within the drawer.

Key features of the locking bin drawers are

- Guiding light technology that provides both drawer location light and lights on individual product bins
- Single and double-deep drawers
- Three bin sizes and drawer configurations: 6 double-deep bins, 12 bins, or 24 bins
- Tamper-proof, locked metal lids
- Supports zone configuration for increased control over pharmacy items
- Capacity of up to 24 line items per drawer

Table 16: High Security Locking Bin Drawer Configurations

Drawer	Specifications (metric)		Security	Best Use
6-Bin Locking	Model #	OLL6	High	Bulky narcotic boxes or higher PAR items
	# of Bins:	6		
	Bin W x H x D:	5.7" x 3.6" x 8.1" (14.45 x 9.14 x 20.57 cm)		
	Drawer W x H x D:	21.5" x 5.1" x 22.5" (54.61 x 12.95 x 57.15 cm)		
	Weight:	36 lb [empty] (16.33 kg)		
8-Bin Locking	Model #:	MDA-DRW-004	High	
	# of Bins:	8		Note: Introduced with G4, but supported on CT 14.6 and higher
	Bin W x H x D:	4 at: 12.79" x 1.8" x 2.92" (32.49 x 4.57 x 7.42cm) and 4 at: 6.1"x 1.8" x 3.4" (15.5 x 4.57 x 8.64 cm)		
	Drawer W x H x D:	21.5" x 2.5" x 22.5" (54.61 x 6.35 x 57.15 cm)		
	Weight	31 lb [empty] (14.52 kg)		

Drawer	Specifications (metric)		Security	Best Use
12-Bin Locking	Model #:	OLL12	High	
	# of Bins:	12		
	Bin W x H x D:	6.1" x 1.8" x 3.4" (15.49 x 4.57 x 8.64 cm)		
	Drawer W x H x D:	21.5" x 2.5" x 22.5" (54.61 x 6.35 x 57.15 cm)		
	Weight:	31.5 lb [empty] (14.29 kg)		
24-Bin Locking	Model #:	OLL241	High	Small quantities
	# of Bins:	24		
	Bin W x H x D:	2.7" x 1.8" x 3" (6.86 x 4.57 x 7.62 cm)		
	Drawer W x H x D:	21.5" x 2.5" x 22.5" (54.61 x 6.35 x 57.15 cm)		
	Weight:	32.5 lb [empty] (14.74 kg)		

Low Security Lighted Matrix and Matrix Drawer Specifications

Matrix drawers are available in two models: lighted and unlighted. The lighted matrix drawer provides lower security, with increased flexibility. Lights frame the section and guide the user to the preselected medication, reducing the possibility of errors.

Key features of lighted matrix drawers are:

- Guiding light technology that provides both drawer location light and lights on individual product bins
- Flexible drawer configurations up to 24 bins
- Adjustable bin dividers

- Single-deep drawer
- Capacity of up to 24 line items



The matrix drawer is a high-capacity, low-security unlighted drawer that is suitable for large quantities of less-controlled medications.

Key features of matrix drawers are:

- Flexible drawer configurations up to 96 bins
- Adjustable bin dividers
- Double-deep drawer 4 dividers
- Single-deep drawer capacity of up to 96 line items

Table 17: Low Security Matrix Drawer Configurations

Drawer	Specifications (metric)		Security	Best Use
24-Bin Lighted Matrix	Model #:	0LMD24	Low	
	# of Bins:	4-24		
	Bin W x H x D:	10" x 1.8" x 9.2" (max.) (25.4 x 4.57 x 23.37 cm)		
	Bin W x H x D:	4.9" x 1.8" x 2.9" (min.) (12.45 x 4.57 x 7.37 cm)		
	Drawer W x H x D:	21.5" x 2.5" x 22.5" (54.61 x 6.35 x 57.15 cm)		
	Weight:	20 lb [empty] (9.07 kg)		
96-Bin Matrix	Model #:	OMD48	Low	
	# of Bins:	4-96		
	Bin W x H x D:	9.2" (max.) x 1.8" x 10" (23.37 x 4.57 x 25.4 cm)		

Drawer	Specifications (metric)		Security	Best Use
	Bin W x H x D:	2.4" x 1.8" x 1.4" (min.) (6.1 x 4.57 x 3.56 cm)		
	Drawer W x H x D:	21.5" x 2.5" x 22.5" (54.61 x 6.35 x 57.15 cm)		
	Weight:	20 lb [empty] (9.07 kg)		
Single Deep Anesthesia	Model #:	OASD		
	# of Bins:	Up to 22		
	Bin W x H x D:	20" x 1.7" x 18.5" [max] (50.8 x 4.32 x 46.99 cm)		
	Drawer W x H x D:	21.5" x 2.5" x 22.9" (54.61 x 6.35 x 58.17 cm)		
	Weight:	15.5 lb [empty] (7.03 kg)		
Double Deep Anesthesia	Model #:	OASD2		
	# of Bins:	Up to 13		
	Bin W x H x D:	19.9" x 4.1" x 17.9" [max] (50.55 x 10.41 x 45.47 cm)		
	Drawer W x H x D:	21.5 x 4.9" x 22.9" (54.61 x 12.446 x 58.166 cm)		
	Weight:	25 lb [empty] (11.34 kg)		

Drawer	Specifications (metric)		Security	Best Use
Triple Deep Anesthesia	Model #:	OASD3		
	# of Bins:	Up to 13		
	Bin W x H x D:	19.75" x 5.25" x 17.75" (maximum)		
	Drawer W x H x D:	21.5" x 7.75" x 22.9"		
	Weight:	42 lb [empty] (19.05 kg)		
	Supports weight of:	50 lb		

OmniceLL Cabinet Drawings

This section contains the drawings of various cabinets with physical specifications.

Three-Cell Cabinet

Top View

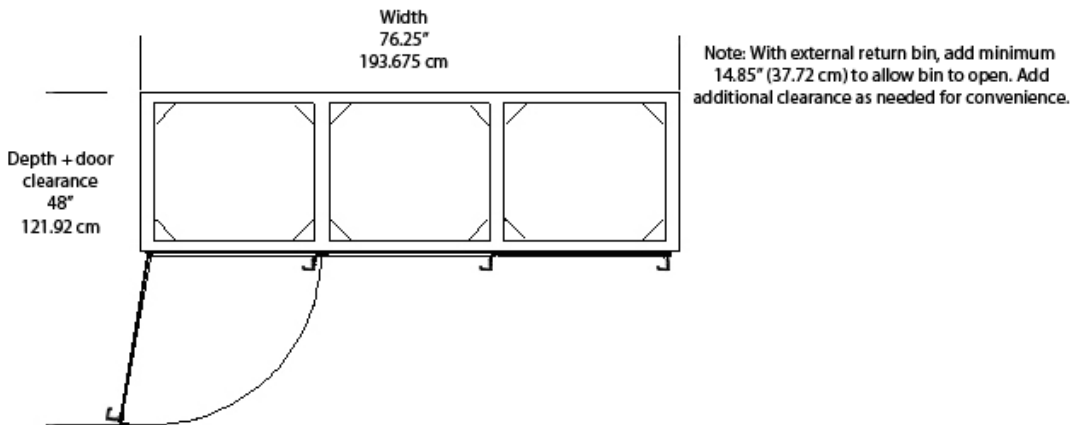

Front View

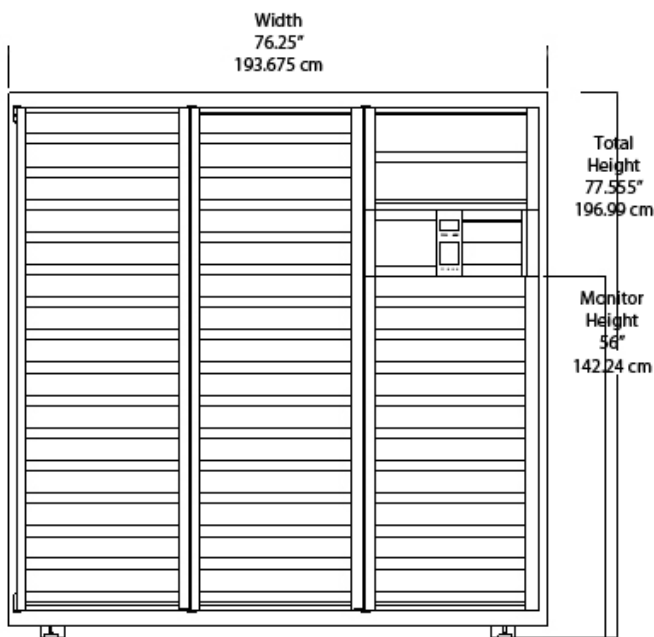

Side View

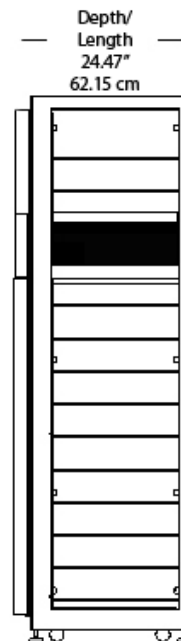

Two-Cell Cabinet

Top View

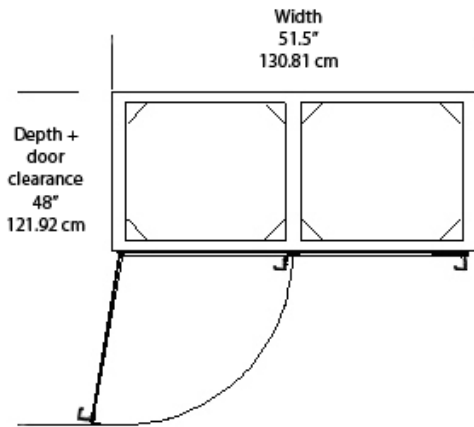

Note: With external return bin, add minimum 14.85" (37.72 cm) to allow bin to open. Add additional clearance as needed for convenience.

Front View

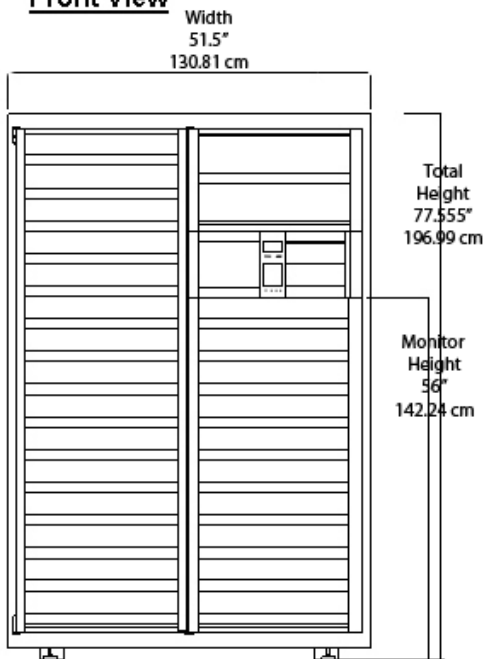

Side View

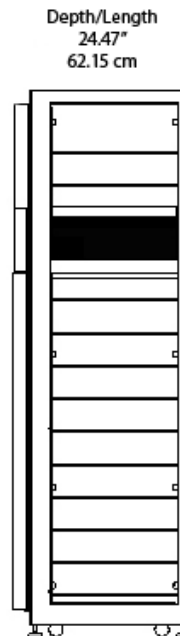

One-Cell Cabinet

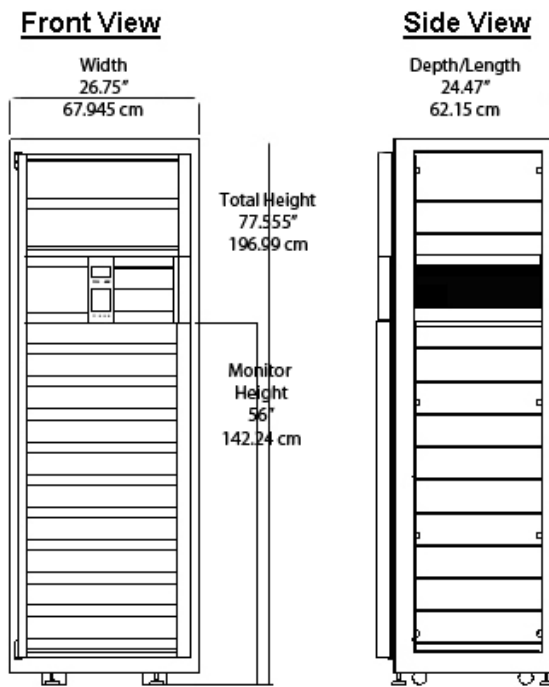
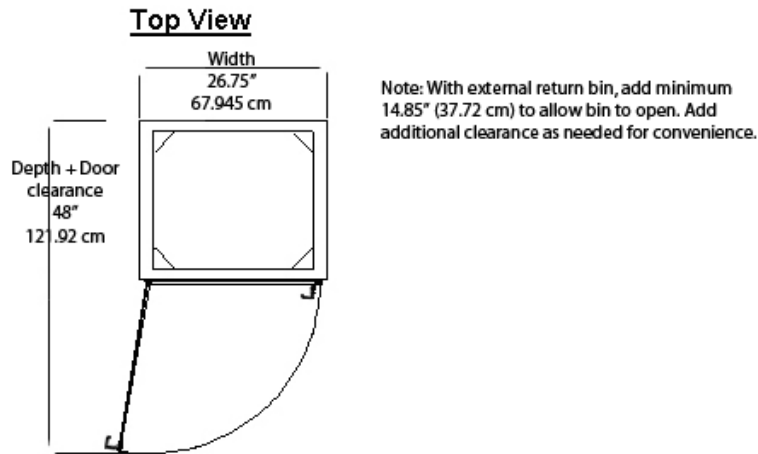

Half-Cell G4

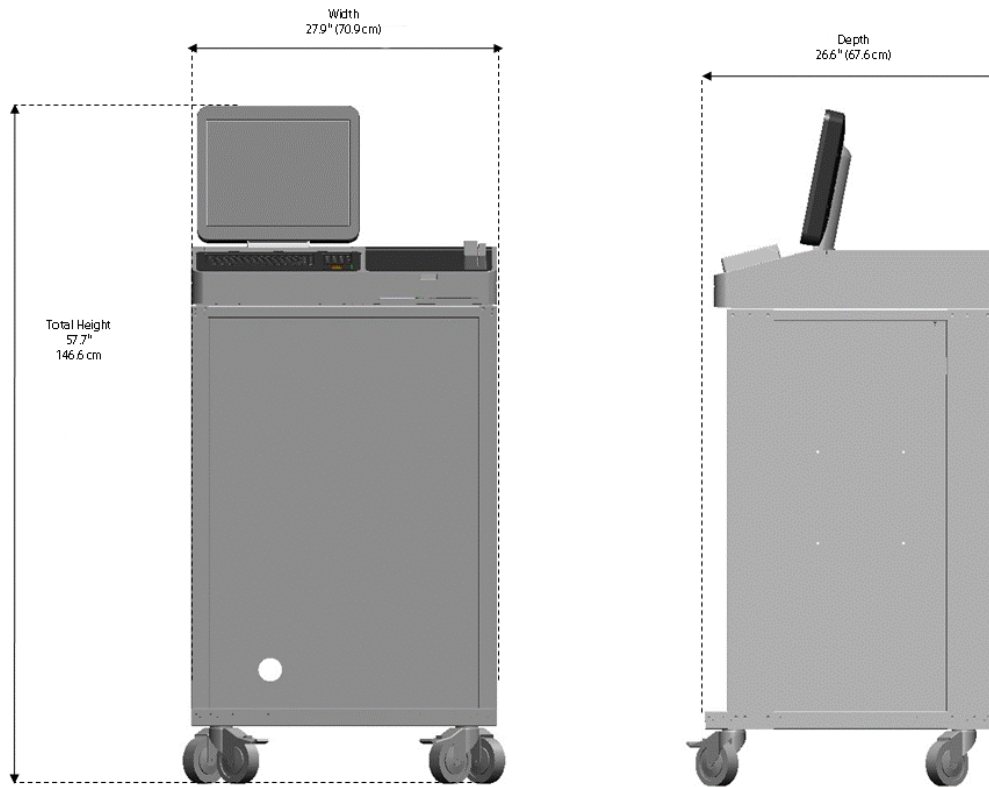

OmniRx G4

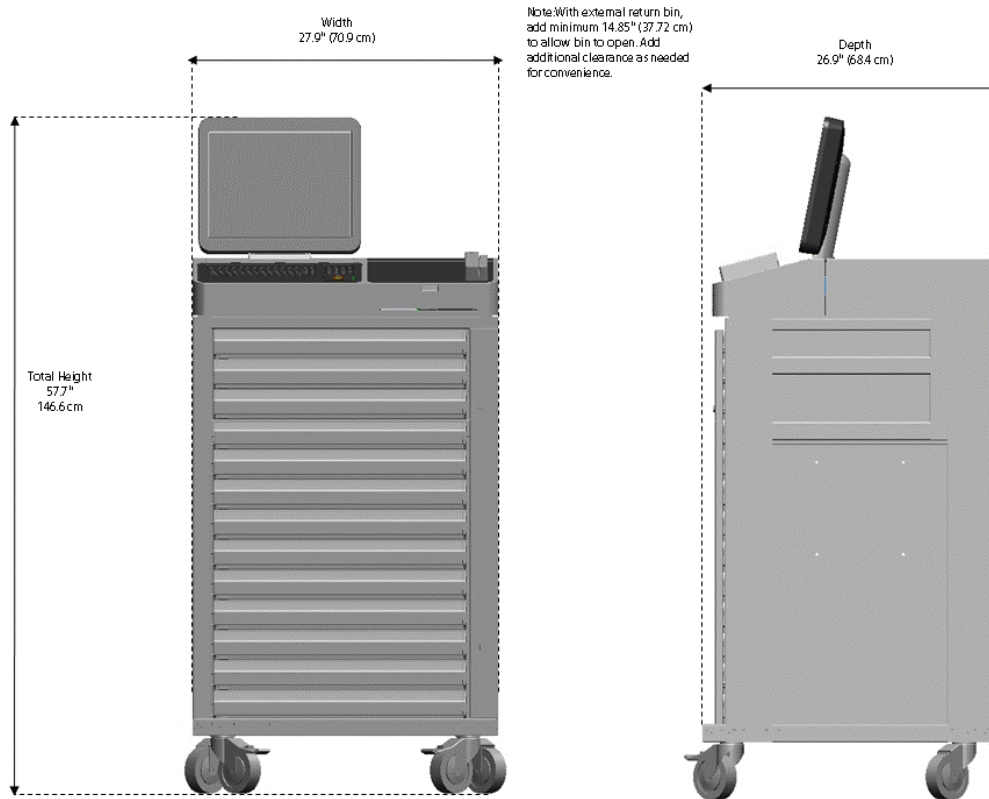

OmniTT G4

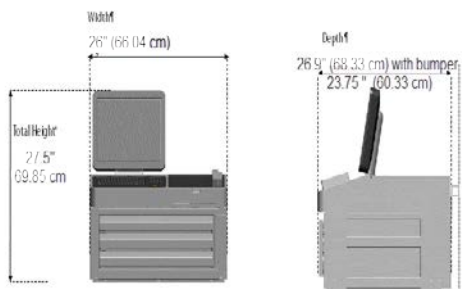

Anesthesia Workstation G4

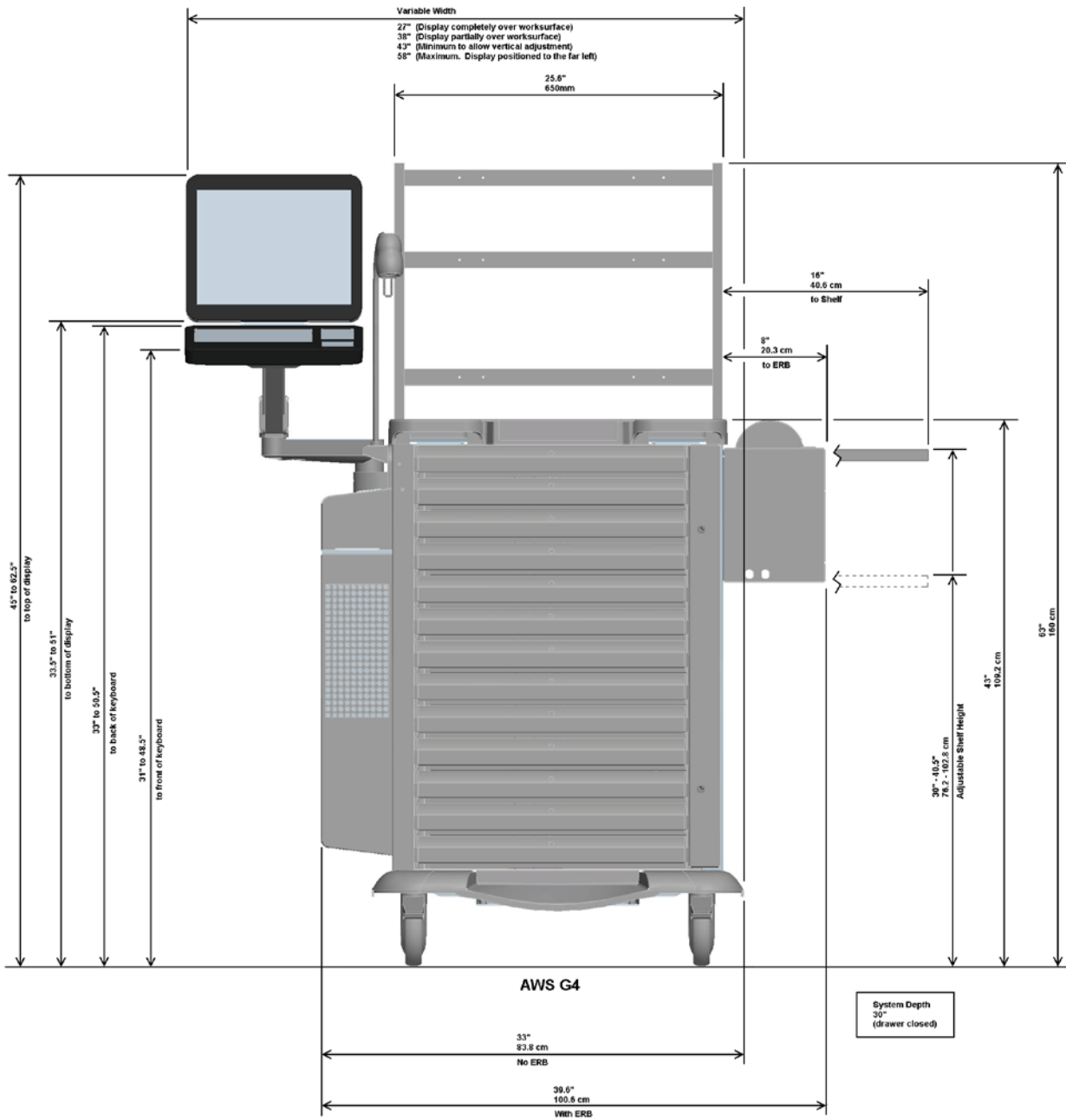

WorkflowRx

WorkflowRx supports a carousel, a packager, and a shelving management only configuration with its software for pharmacy applications. The carousel is a storage and access machine for supplies and medicine. The packager generates dose packaging that is delivered to cabinets in the hospital.

This chapter contains equipment specifications for WorkflowRx. Common specifications that are shared by all hardware products are in the ["OmniCenter/Color Touch"](#) topics. Specifications for the Cybernet iOne H19 workstation are described in ["Appendix C: Cybernet iOne H19 Workstation Specifications"](#).

WorkflowRx Hardware Specifications

OmniceLL delivers the latest models of available hardware in its product lines.

WorkflowRx Server Specifications

Details such as CPU speed, memory size, hard drive size, and other features improve frequently. Listed here is a typical configuration for an Omnicell server.

McAfee VirusScan is used for anti-virus protection. Omnicell vSuite can be used for remote monitoring. HL7 is used for messaging from the hospital's PIS and HIS systems.

All Omnicell servers use the same models and specifications. See ["Omnicell Server Specifications"](#). The configuration and database may vary.

Table 18: Workflow Rx R320 Server Configuration

Item	
Operating System	Windows Server 2012, Standard Embedded R2 (64-bit)
SQL Server	SQL Server 2012
Base Unit	PowerEdge R320, Intel Xeon E-24XX v2 Processors (210-ACCX)
Processor	1 x Intel Xeon E5-2407 v2 - 2.40GHz
Memory - 16GB	1 x 16 GB RDIMM, 1600 MT/s, Low Volt, Dual Rank, x4 Data Width (319-1812)
Hard Drive	C: 136 GB D: 836 GB

Item	
.NET 3.5 SP1	
Dell Open Manager 7.2	
OIS 6.2.0.260	

WorkflowRx Client Hardware (Workstation/Pick Engine)

A Cybernet iOne H19, a Dell Optiplex, or a customer-provided system is used.

- The Cybernet AIO workstation specifications are found in "[Appendix C: Cybernet iOne H19 Workstation Specifications](#)".



A product key is required for each workstation, handheld/tablet PC, server, and pick engine (#70-0155).

WorkflowRx Electrical Requirements

Omicell requires the facility to provide electrical service according to Omnicell equipment specifications. Packagers must be within six feet of an electrical outlet. All units require an emergency power source. The facility is responsible for all electrical and cabling costs.

Product	Voltage (VAC)
System Logistics Carousel	3-phase; 208-240 V AC/ 60 Hz / 30 A 115-120 V AC / 60 Hz/ 20 A for courtesy outlets
JV Medi Packager	120V / 60Hz Canadian Standard Association (CSA) 230V / 240V / 50Hz European Conformity (CE) 220V / 60Hz (Korea)
Yuyama Packager	120V AC/230V AC; 12.5 A max; 50-60 Hz

Carousel Computer Electrical Requirements

A small UPS is supplied with the carousel for the computer. It is sized to fit within the carousel. A UPS is not applicable for the carousel motors because they have unique power requirements. A generator can be used for backup power.

A carousel can be rotated manually with corded drills (supplied) that use 120V power. A separate 120 V AC power drop is needed for a quadruple (quad; 4-plug) outlet.

Power drops are recommended to be from an emergency power source to ensure carousel function during power interruptions.

Carousel Computer UPS Specifications

Table 19: Carousel Computer UPS Specifications

Type of Parameter	Parameter	Specification
Output	Output power capacity	200 watts / 350 VA
	Max configurable power	200 Watts / 350 VA
	Nominal output voltage	120V
	Waveform type	Stepped approximation to a sinewave
	Output Connections	(3) NEMA 5-15R (Battery backup) (3) NEMA 5-15R (Surge protection)
Input	Nominal input voltage	120V
	Input frequency	60 Hz +/- 1 Hz
	Input connections	NEMA 5-15P
	Cord length	4.98 feet (1.52 m)
	Input voltage range for main operations	88 - 139V
Batteries & Runtime	Battery type	Maintenance-free sealed lead-acid battery with suspended electrolyte: leakproof

Type of Parameter	Parameter	Specification
	Typical recharge time	16 hours
	Replacement battery	RBC35
	RBC quantity	1
Communications & Management	Control panel	LED status display with On Line : On Battery : Replace Battery and Building Wiring Fault
	Audible alarm	Alarm when on battery : distinctive low battery alarm : overload continuous tone alarm
Surge Protection & Filtering	Surge energy rating	365 Joules
	Filtering	Full time multi-pole noise filtering : 5% IEEE surge let-through : zero clamping response time : meets UL 1449
	Data line protection	RJ-11 Modem/Fax/DSL protection (two wire single line)
Physical	Maximum height	3.51" (89.0 mm)
	Maximum width	6.26" (159.0 mm)
	Maximum depth	10.99" (279.0 mm)
	Net weight	8.03 lb (3.64 Kg)
	Shipping weight	8.62 lb (3.91 Kg)
	Shipping height	7.76" (197.00 mm)
	Shipping width	14.26" (362.0 mm)

Type of Parameter	Parameter	Specification
	Shipping depth	5" (127.0 mm)
	Master carton units	2.00
	Master carton weight	17.53 lb (7.95 Kg)
	Color	Charcoal
	SCC codes	1073130425890 9
	Units per pallet	120.00
Environmental	Operating environment	0 - 40° C (32 - 104 °F)
	Operating relative humidity	5 - 95%
	Operating elevation	(0 - 9842.51 feet) (0-3000 m)
	Storage temperature	-15 to 45° C (5 to 113° F)
	Storage relative humidity	5 - 95%
	Storage elevation	0 - 49212.60 feet (0-15000 m)
	Audible noise at 1 meter from surface of unit	45.00 dBA
	Online thermal dissipation	14.00 BTU/hr
Conformance	Regulatory approvals	cUL listed,FCC Part 15 Class B,FCC Part 68,NOM,UL 1778,UL 4997 A,UL 498

Type of Parameter	Parameter	Specification
	Standard warranty	3 years repair or replace
	Equipment protection policy	Lifetime : \$75,000.00

Packager Electrical Requirements

- Equipment must be connected to the emergency power red wall plugs.
- Required minimum: one quad outlet
- Preferred: two quad outlets for redundancy and flexibility
 - One quad should be on the wall in back of the packager.
 - The other quad should be on the wall where the printer, workstation, and UPS are located.
 - If the server cannot be connected in the data center, it will be connected in the pharmacy.

Packager UPS Protection

In order to prevent power problems from damaging the packager, the equipment has built-in UPS with surge-suppression circuitry. The UPS can provide up to 15 minutes of power when voltage levels become erratic or fail. The facility is responsible for testing and changing the battery in UPS units.



The battery in UPS unit must be connected during installation because Omnicell is required to disconnect battery cables prior to shipping. When connecting an OmniCenter server to an external UPS, do not plug the printer or computer monitor into the UPS unit.

Table 20: Packager UPS Specifications

Type of Parameter	Parameter	Specification
Output	Output power capacity	780 watts/ 1300 VA
	Nominal output voltage	120V
	Output frequency (sync to mains)	50/60Hz +/- 3 Hz user adjustable +/- 0.1
	Waveform type	Stepped approximation to a sinewave

Type of Parameter	Parameter	Specification
	Output connections	(5) NEMA 5-15R (Battery backup) (5) NEMA 5-15R (Surge protection)
Input	Nominal input voltage	120V
	Input frequency	50/60/Hz +/- 3Hz (auto sensing)
	Input connections	NEMA 5-15P
	Cord length	6' (1.83 m)
Batteries & Runtime	Battery type	Maintenance-free sealed lead-acid battery with suspended electrolyte: leakproof
	Included battery modules	1
	Typical recharge time	8 hours
	Replacement battery	APCRBC124
	RBC quantity	1
Communications & Management	Interface ports	USB
	Control panel	Multi-function LCD status and control console
	Audible alarm	Alarm when on battery : distinctive low battery alarm : overload continuous tone alarm
Surge Protection & Filtering	Surge energy rating	355 Joules

Type of Parameter	Parameter	Specification
	Filtering	Full time multi-pole noise filtering : 5% IEEE surge let-through : zero clamping response time : meets UL 1449
	Data line protection	Network line - 10/100/1000 Base-T ethernet (RJ-45 connector), coaxial cable for CATV/SATV/modem audio-video (coax connector)
Physical	Maximum height	11.89" (302 mm)
	Maximum width	4.41" (112 mm)
	Maximum Depth	15.00" (381 mm)
	Net weight	28.35 lb (12.86 kg)
	Shipping weight	28.46 lb (12.91 kg)
	Shipping height	15.0" (381 mm)
	Shipping width	9.02" (229 mm)
	Shipping depth	19.02" (483 mm)
	SCC codes	1073130426876 2
	Units per pallet	24.00
Environmental	Operating environment	0 - 40° C (32 - 104 ° F)
	Operating relative humidity	0 - 95%
	Operating elevation	0 - 9842.51' (0-3000 m)

Type of Parameter	Parameter	Specification
	Storage temperature	23 - 113° F (-5-45° C)
	Storage relative humidity	0 - 95%
	Storage elevation	0 - 49212.60' (0-15000 m)
	Audible noise at 1 meter from surface of unit	45.00 dBA
Conformance	Regulatory approvals	FCC Part 15 Class B, NOM,TUV, UL 1778
	Standard warranty	3 years repair or replace
	Environmental compliance	RoHS, REACH: Contains no SVHCs

WorkflowRx Communication Requirements

The facility must satisfy these requirements for WorkflowRx communication.

Carousel

To ensure that the Omnicell system interfaces properly with the network, the facility must provide:

- An IP address for each of the following:
 - Carousel (static IP)
 - Carousel light bar (static IP)
 - Printer (static IP)
 - Workstation (static IP or DHCP)
- 4 LAN drops
- Subnet mask addresses
- Network port
- Category 6 cabling
- Remote access
 - vSuite solution [preferred]
 - Virtual Private Network (VPN) solutions [used only if vSuite is not supported]

The customer should state their preference. The customer must provide the hospital security forms to Omnicell for filling out the required information.

- Server housing (preferred location is in the hospital's data center)
- Confirmation of server model (rack or tower)

Packager

- 3 LAN drops, 2 static IP addresses
- One (Category 6 or higher) RJ-45 connection for each packager network device, printer, workstation, and UPS
 - VPN or other Hospital IT access point; the customer should state their preference.
 - Hospital security forms for Omnicell to fill out the required information
- Remote monitoring using Omnicell vSuite
- Server housing in the hospital's data center (preferred)
- Confirmation of server model (rack or tower)

WorkflowRx Environment

The following general environment requirements must be met. Additional information is provided in separate topics.

- Ensure there is adequate dock space to unload the equipment.
- Floor load rating must be adequate to support the equipment:
 - System Logistics Carousels: 102.5-179.8 lb/sq. ft. (or) 500.45 - 877.86 kg/sq. m depending on model.
 - JV Medi packager: 106-182 lb/sq. ft. (or) 517.54 - 888.6 kg/sq. m depending on model
 - Yuyama packager: 269-320 lb/caster (or) 122-145 kg/caster
- Hospital door openings must be wider than the packager by at least one inch to move it into the pharmacy.
- Room temperature should be regulated between 20° C and 25° C (68°-77° F) for medications or between 15° C and 30° C (59°-86° F) for general supplies. Brief deviations are allowed for supplies.
- Maximum humidity must not exceed 80%.
- Covers to electrical controls must be kept in place to prevent contact, damage, or contamination of electrical components. Remove dust from electrical components by vacuuming. Do not use forced air to clean electrical components.
- Machine anchor strength must be adequate to prevent shifting of the machine during operation.

WorkflowRx Heat Dissipation

The table shown here contains useful information for determining a site's heating and ventilation setup so that room temperatures can be maintained with the WorkflowRx installed.

Cabinet	Type	Heat Dissipation
Carousel	All	Heating ventilation and air conditioning (HVAC) requirements: 1500-2000 BTU/hr (intermittent when motor is running)

Cabinet	Type	Heat Dissipation
JV Medi Packager	Slide	Stand-by (heater operating). Duration of heater is heated. [631W = 2,153BTU/hr = 543 Kcal/hr] Normal load, after heater is heated. [279W = 952BTU/hr = 240Kcal/hr] Full load: Exception of canister motor part. [655W = 2,235BTU/hr = 563Kcal/hr] Peak load, full operation of unit, including canisters. [800W = 2,730BTU/hr = 688Kcal/hr]
	Box	Stand-by (heater operating). Duration of heater is heated. [557W = 1,901BTU/hr = 479Kcal/hr] Normal load, after heater is heated. [281W = 959BTU/hr = 242Kcal/hr] Full load: Exception of canister motor part. [655W = 2,234BTU/hr = 563Kcal/hr] Peak load, full operation of unit, including canisters. [900W = 3,071BTU/hr = 774Kcal/hr]
Yuyama Packager	All	Stand-by (heating up): 0.34 BTU/hr Normal operation: 0.2 BTU/hr Wait (ready between operations): 0.23 BTU/hr

WorkflowRx Seismic Restraints

The seismic design (pinned weldment) for the Yuyama packager has been approved by the state of California.

See "[Appendix B: Seismic Specifications](#)".

WorkflowRx Safety/Quality Certifications

WorkflowRx is certified by various organizations, including:

- Canadian Standards Association (CSA)
- European Conformity (CE)
- Underwriters Laboratories (UL)
- Federal Communication Commission (FCC)
- Food & Drug Administration (FDA)

Product	Certifications
Carousel	UL (electric panel)
JV Medi Packager	CSA (vendor-provided) and CE for power supply; FDA for Class B packaging paper and printing materials

Product	Certifications
Yuyama Packager	FDA for Class B packaging paper and printing materials, Nemco RSS 210 Issue, EC for low voltage and EMC directives; MET certified for electrical equipment

WorkflowRx Carousel and Packager Specifications

This topic contains standard WorkflowRx specifications.

- Standard width of carousel: 143.70" (365 cm)
- Additional width of 18" (45.72 cm) required on *both* sides and *between* carousels for service access.
- Standard depth: 89.28" (229.31 cm) = carousel footprint depth 68.11" (173 cm) + counter depth 22.17" (56.31 cm)
- Printer drawer extends standard depth 19" (48.26 cm) when pulled out for service.
- Install height 2" (5.08 cm) greater than machine height
- Clearance for user operation in front (specific requirement varies)

WorkflowRx Large Carousel Dimensions

These documents show specifications of the large carousel, by carousel model.



WorkflowRx™ System Logistics Carousel Dimensions

This document provides the physical dimensions for the System Logistics Model 70B vertical carousels

System Logistics Model 70B Vertical Carousel Specifications													
(118.11" Carrier Width – 24.6" Carrier Depth)													
Model/ Omnicell PN	Carriers per Unit (#)	Total Possible Shelves (#)	Totes per Shelf (#)	Bins per Shelf (#)	Slots per Shelf (#)	Slots per Device (#)	¹ Total Vol. (Cubic Ft.)	Device Weight (Lbs.)	⁵ Live Load (Lbs.)	Max. Unit Weight (Lbs.)	² Width (In.)	³ Depth (In.)	⁴ Height (In.)
70-B250-355-8-625 WRX-CR-001	8	16	14	28	112	1,792	99.13	5,543	3,688	9,231	143.7	89.72	92.12
70-B250-355-10-625 WRX-CR-002	10	20	14	28	112	2,240	123.92	6,373	4,610	10,983	143.7	89.72	107.29
70-B250-355-12-625 WRX-CR-003	12	24	14	28	112	2,688	148.70	7,100	5,532	12,632	143.7	89.72	120.59
70-B250-355-14-625 WRX-CR-004	14	28	14	28	112	3,136	173.48	7,949	6,454	14,403	143.7	89.72	135.04
70-B250-355-16-625 WRX-CR-005	16	32	14	28	112	3,584	198.27	8,824	7,376	16,200	143.7	89.72	149.21

Installation Requirements:

- A minimum of 18.0" side access on the left & right of the carousel is required for service access.
- If installed side-by-side, 18.0" between machines and 18.0" on left side of left most machine and 18.0" on right side of right most machine is required.
- A minimum of 2.0" above the height of the system is required.

HVAC Requirements:

1,500 – 2,000 BTU's / Hr. when motors are operating.

¹ Nominal total volume total possible totes; Assumes all dividers are installed to provide maximum slots per device. Assumes totes are filled to the top, but not beyond tote walls, and all shelves in the carousel are used. Nominal size of tote is 24.0" (L) x 8.0" (W) x 5.0" (H) and nominal size of each slot is 5.75" (L) x 3.5" (W) x 4.75" (H), with eight possible slots per tote (4 per bin).

² Excluding minimum 18.0" side access on left and right required for servicing.

³ Depth includes 22.17" deep front work counter.

⁴ Minimum two inches required above height for installation.

⁵ Live load capacity, includes the weight of the additional shelf levels and shelf supports within the carriers.

Network Connectivity (Carousel Equipment):

4 – IP Addresses required per carousel:

- 1 – Carousel (static IP)
- 1 – Carousel Light Bar (static IP)
- 1 – Carousel Printer (static IP)
- 1 – Carousel Workstation (static IP or DHCP)

Electrical Requirements:

- 3 Phase, 208-240 V (no neutral required), 60 Hz, 30 A (per carousel)
- Single Phase, 115-120 V, 60 Hz, 20 A (per carousel)
- Strongly recommend all power drops are provided from an emergency power source to ensure carousel(s) function during power interruptions



Certification

- UL certified



Allow 24"-36" side access clearance for initial installation. After installation is complete, only 18" side access clearance is required.

Model 70B Carousels: 67-2148 Rev B

WorkflowRx™ System Logistics Carousel Details

Model 70B Vertical Carousel					
Model	70-B250-355-8-625 WRX-CR-001	70-B250-355-10-625 WRX-CR-002	70-B250-355-12-625 WRX-CR-003	70-B250-355-14-625 WRX-CR-004	70-B250-355-16-625 WRX-CR-005
Number of Carriers per Unit	8	10	12	14	16
Carrier Width (In.)	118.11	118.11	118.11	118.11	118.11
Carrier Depth (In.)	24.6	24.6	24.6	24.6	24.6
Gross Carrier Capacity (Lbs.)	461	461	461	461	461
Carrier Clear Height (In.)	11.73	11.73	11.73	11.73	11.73
Shelf Level Clear Height (In.)	5.31	5.31	5.31	5.31	5.31
Unit Height (In.)	92.12	107.29	120.59	135.04	149.21
Unit Width (In.)	143.7	143.7	143.7	143.7	143.7
Unit Depth (In.)	67.55	67.55	67.55	67.55	67.55
Work Counter Depth (In.)	22.17	22.17	22.17	22.17	22.17
Total Unit Depth ⁽¹⁾ (In.)	89.72	89.72	89.72	89.72	89.72
Unit Capacity (Live Load) ⁽²⁾ (Lbs.)	3,688	4,610	5,532	6,454	7,376
Total Max. Unit Weight ⁽³⁾ (Lbs.)	9,231	10,983	12,632	14,403	16,200
Additional Shelf Weight ⁽⁴⁾ (Lbs.)	102	102	102	102	102
Footprint (Sq. Ft.)	90.1	90.1	90.1	90.1	90.1
Floor Load (PSF)	102.5	121.9	140.2	159.9	179.8
Max. Loading per Base Plate (PSI)	20.6	24.6	28.3	32.2	36.2
Imbalance (%)	100	100	100	100	100
Chain Pitch (In.)	1.0	1.0	1.0	1.0	1.0
Required Room Height (In.)	94	109	123	137	151

(1) Includes work counter depth, (2) Gross Carrier Capacity x Number of Carriers, (3) Unit Capacity + Device Weight, (4) Shelf Weight, if installed in a carrier, reduces carrier capacity to 359 lbs.

WorkflowRx™ System Logistics Carousel Details

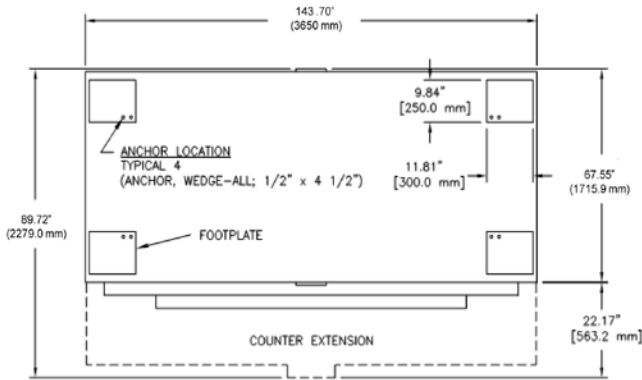

NUMBER OF CARRIERS	MACHINE WEIGHT LOADED	AVERAGE LOAD OVER BASE AREA (PSF)*	LOADING PER BASE PLATE (PSI)**
8	9,231 Lbs.	102.5 PSF	20.6 PSI
10	10,983 Lbs.	121.9 PSF	24.6 PSI
12	12,632 Lbs.	140.2 PSF	28.3 PSI
14	14,403 Lbs.	159.9 PSF	32.2 PSI
16	16,200 Lbs.	179.8 PSF	36.2 PSI

* = POUND PER SQUARE FOOT FOR THE ENTIRE MACHINE BASE AREA.
 ** = POUND PER SQUARE INCH POINT LOADING AT EACH BASE PLATE.

LOADS BASED ON MAXIMUM PRODUCT LOAD OF 461 POUND PER CARRIER.

MODEL 70 VERTICAL CAROUSEL FOOTPRINT
 OMNICELL MODELS 70-B250-355-X-625



WorkflowRx Special 20-Carrier Carousel Dimensions

The documents here show specifications of the special 20-Carrier carousel.

Special 20-Carrier Model 70B Carousel: 67-2160 Rev B

WorkflowRx™ System Logistics Carousel Dimensions

This document provides the physical dimensions for the System Logistics Special Model 70B, 20 carrier vertical carousel.

System Logistics Model 70B Vertical Carousel Specifications													
(118.11" Carrier Width – 24.6" Carrier Depth)													
Model/ Omnicell PN	Carriers per Unit (#)	Total Possible Shelves (#)	Totes per Shelf (#)	Bins per Shelf (#)	Slots per Shelf (#)	Slots per Device (#)	¹ Total Vol. (Cubic Ft.)	Device Weight (Lbs.)	⁵ Live Load (Lbs.)	Max. Unit Weight (Lbs.)	² Width (In.)	³ Depth (In.)	⁴ Height (In.)
70-B250-355-20-625 WRX-CAR-006	20	40	14	28	112	4,480	247.84	10,488	8,000	18,488	143.7	90.28	178.4

Installation Requirements:

- A minimum of 18.0" side access on the left & right of the carousel is required for service access.
- If installed side-by-side, 18.0" between machines and 18.0" on left side of left most machine and 18.0" on right side of right most machine is required.
- A minimum of 2.0" above the height of the system is required.

Electrical Requirements:

- 3 Phase, 208-240 V (no neutral required), 60 Hz, 30 A (per carousel)
- Single Phase, 115-120 V, 60 Hz, 20 A (per carousel)
- Strongly recommend all power drops are provided from an emergency power source to ensure carousel(s) function during power interruptions

¹ Nominal total volume total possible totes; Assumes all dividers are installed to provide maximum slots per device. Assumes totes are filled to the top, but not beyond tote walls, and all shelves in the carousel are used. Nominal size of tote is 24.0" (L) x 8.0" (W) x 5.0" (H) and nominal size of each slot is 5.75" (L) x 3.5" (W) x 4.75" (H), with eight possible slots per tote (4 per bin).

² Excluding minimum 18.0" side access on left and right required for servicing.

³ Depth includes 22.17" deep front work counter.

⁴ Minimum two inches required above height for installation.

⁵ Live load capacity, includes the weight of the additional shelf levels and shelf supports within the carriers.

Network Connectivity (Carousel Equipment):

- 4 – IP Addresses required per carousel:
- 1 – Carousel (static IP)
 - 1 – Carousel Light Bar (static IP)
 - 1 – Carousel Printer (static IP)
 - 1 – Carousel Workstation (static IP or DHCP)

HVAC Requirements:

1,500 – 2,000 BTU's / Hr. when motors are operating.

Special Model Considerations:

- Special 20-Carrier models currently do not carry a UL certification.
- Carrier load capacity is 400 Lbs. maximum per carrier, including the weight of the additional shelf level and supports.
- Unit imbalance is 70% of the live load maximum.



Allow 24"-36" side access clearance for initial installation. After installation is complete, only 18" side access clearance is required.

Model 70B Carousels: 67-2160 Rev B

WorkflowRx™ System Logistics Carousel Details

Special Model 70B Vertical Carousel	
Model	70-B250-355-20-625 WRX-CAR-006
Number of Carriers per Unit	20
Carrier Width (In.)	118.11
Carrier Depth (In.)	24.6
Gross Carrier Capacity (Lbs.)	400
Carrier Clear Height (In.)	11.73
Shelf Level Clear Height (In.)	5.31
Unit Height (In.)	178.4
Unit Width (In.)	143.7
Unit Depth (In.)	68.11
Work Counter Depth (In.)	22.17
Total Unit Depth ⁽¹⁾ (In.)	90.28
Unit Capacity (Live Load) ⁽²⁾ (Lbs.)	8,000
Total Max. Unit Weight ⁽³⁾ (Lbs.)	18,488
Additional Shelf Weight ⁽⁴⁾ (Lbs.)	102
Footprint (Sq. Ft.)	90.0
Floor Load (PSF)	205.21
Max. Loading per Base Plate (PSI)	39.76
Imbalance (%)	70
Chain Pitch (In.)	1.0
Required Room Height (In.)	180.4



⁽¹⁾ Includes work counter depth, ⁽²⁾ Gross Carrier Capacity x Number of Carriers, ⁽³⁾ Unit Capacity Including Additional Shelf Dead Weight + Unit Weight ⁽⁴⁾ Shelf Weight, if installed in a carrier, reduces carrier capacity to 298 lbs.



Model 70B Carousels: 67-2160 Rev B

WorkflowRx™ System Logistics Carousel Details

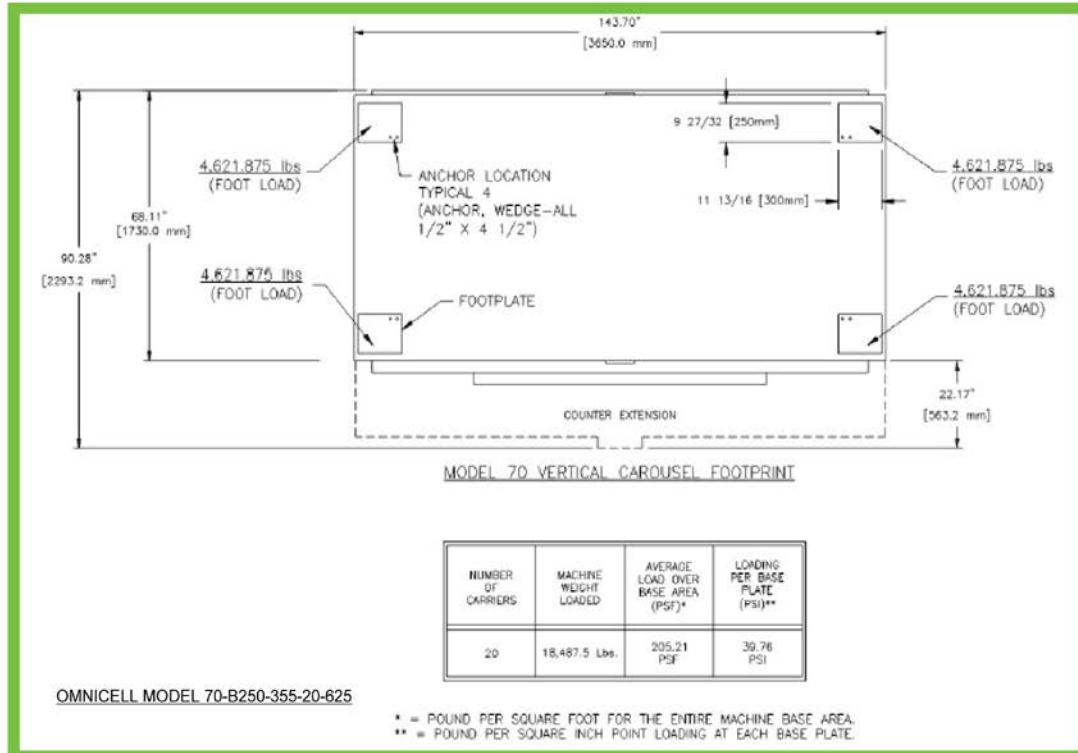

WorkflowRx Small Footprint Carousel Dimensions

The documents here show specifications of the small footprint carousel by carousel model.



WorkflowRx™ System Logistics Carousel Dimensions (Small Footprint)

This document provides the physical dimensions for the System Logistics Model 70A vertical carousels

System Logistics Small Footprint Model 70A Vertical Carousel Specifications													
(89.37" Carrier Width – 15.74" Carrier Depth)													
Model/ Omnicell PN	Carriers per Unit (#)	Total Possible Shelves (#)	Totes per Shelf (#)	Bins per Shelf (#)	Slots per Shelf (#)	Slots per Device (#)	¹ Total Vol. (Cubic Ft.)	Device Weight (Lbs.)	⁵ Live Load (Lbs.)	Max. Unit Weight (Lbs.)	² Width (In.)	³ Depth (In.)	⁴ Height (In.)
70A-250-355-8-400 WRX-CAR-001	8	16	11	22	66	1,056	46.99	4,331	3,688	8,019	114.96	72.01	86.61
70A-250-355-10-400 WRX-CAR-002	10	20	11	22	66	1,320	58.74	4,826	4,610	9,436	114.96	72.01	100.39
70A-250-355-12-400 WRX-CAR-003	12	24	11	22	66	1,584	70.48	5,481	5,532	11,013	114.96	72.01	114.17
70A-250-355-14-400 WRX-CAR-004	14	28	11	22	66	1,848	82.23	6,078	6,454	12,532	114.96	72.01	127.95
70A-250-355-16-400 WRX-CAR-005	16	32	11	22	66	2,112	93.98	6,679	7,376	14,055	114.96	72.01	142.52

Installation Requirements:

- A minimum of 18.0" side access on the left & right of the carousel is required for service access.
- If installed side-by-side, 18.0" between machines and 18.0" on left side of left most machine and 18.0" on right side of right most machine is required.
- A minimum of 2.0" above the height of the system is required.

HVAC Requirements:

1,500 – 2,000 BTU's / Hr. when motors are operating.

¹ Nominal total volume of total possible totes; Assumes all dividers are installed to provide maximum slots per device. Assumes totes are filled to the top, but not beyond tote walls, and all shelves in the carousel are used. Nominal size of tote is 15.0" (L) x 8.0" (W) x 5.0" (H) and nominal size of each slot is 4.625" (L) x 3.5" (W) x 4.75" (H), with six (6) possible slots per tote (3 per bin).

² Excluding minimum 18.0" side access on left and right required for servicing.

³ Depth includes 22.17" deep front work counter.

⁴ Minimum two inches required above height for installation.

⁵ Live load capacity, includes the weight of the additional shelf levels and shelf supports within the carriers.

Network Connectivity (Carousel Equipment):

- 4 – IP Address required per carousel:
- 1 – Carousel (static IP)
 - 1 – Carousel Light Bar (static IP)
 - 1 – Carousel Printer (static IP)
 - 1 – Carousel Workstation (static IP or DHCP)

Electrical Requirements:

- 3 Phase, 208-240 V (no neutral required), 60 Hz, 30 A (per carousel)
- Single Phase, 115-120 V, 60 Hz, 20 A (per carousel)
- Strongly recommend all power drops are provided from an emergency power source to ensure carousel(s) function during power interruptions

Small footprint models currently do not carry a UL certification.



Allow 24"-36" side access clearance for initial installation. After installation is complete, only 18" side access clearance is required.

WorkflowRx™ System Logistics Carousel Details (Small Footprint)

Reduced Footprint Model 70A Vertical Carousel					
Model	70A-250-355-8-400 WRX-CAR-001	70A-250-355-10-400 WRX-CAR-002	70A-250-355-12-400 WRX-CAR-003	70A-250-355-14-400 WRX-CAR-004	70A-250-355-16-400 WRX-CAR-005
Number of Carriers per Unit	8	10	12	14	16
Carrier Width (In.)	89.37	89.37	89.37	89.37	89.37
Carrier Depth (In.)	15.74	15.74	15.74	15.74	15.74
Gross Carrier Capacity (Lbs.)	461	461	461	461	461
Carrier Clear Height (In.)	11.73	11.73	11.73	11.73	11.73
Shelf Level Clear Height (In.)	5.31	5.31	5.31	5.31	5.31
Unit Height (In.)	86.61	100.39	114.17	127.95	142.52
Unit Width (In.)	114.96	114.96	114.96	114.96	114.96
Unit Depth (In.)	49.84	49.84	49.84	49.84	49.84
Work Counter Depth (In.)	22.17	22.17	22.17	22.17	22.17
Total Unit Depth ⁽¹⁾ (In.)	72.01	72.01	72.01	72.01	72.01
Unit Capacity (Live Load) ⁽²⁾ (Lbs.)	3,688	4,610	5,532	6,454	7,376
Total Max. Unit Weight ⁽³⁾ (Lbs.)	8,019	9,436	11,013	12,532	14,055
Additional Shelf Weight (Lbs) ⁽⁴⁾	59	59	59	59	59
Footprint (Sq. Ft.)	57.49	57.49	57.49	57.49	57.49
Floor Load (PSF)	139.50	164.14	191.57	218.00	244.49
Max. Loading per Base Plate (PSI)	17.25	20.30	23.70	26.96	30.24
Imbalance (%)	100	100	100	100	100
Chain Pitch (In.)	1.0	1.0	1.0	1.0	1.0
Required Room Height (In.)	88.60	102.40	116.20	130.00	144.50

⁽¹⁾ Includes Work Counter Depth, ⁽²⁾ Gross Carrier Capacity x Number of Carriers, ⁽³⁾ Unit Capacity Including Additional Shelf Dead Weight + Unit Weight ⁽⁴⁾ Shelf weight, if installed in a carrier, reduces carrier capacity to 402 lbs.



Allow 24"-36" side access clearance for initial installation. After installation is complete, only 18" side access clearance is required.

WorkflowRx™ System Logistics Carousel Details (Small Footprint)

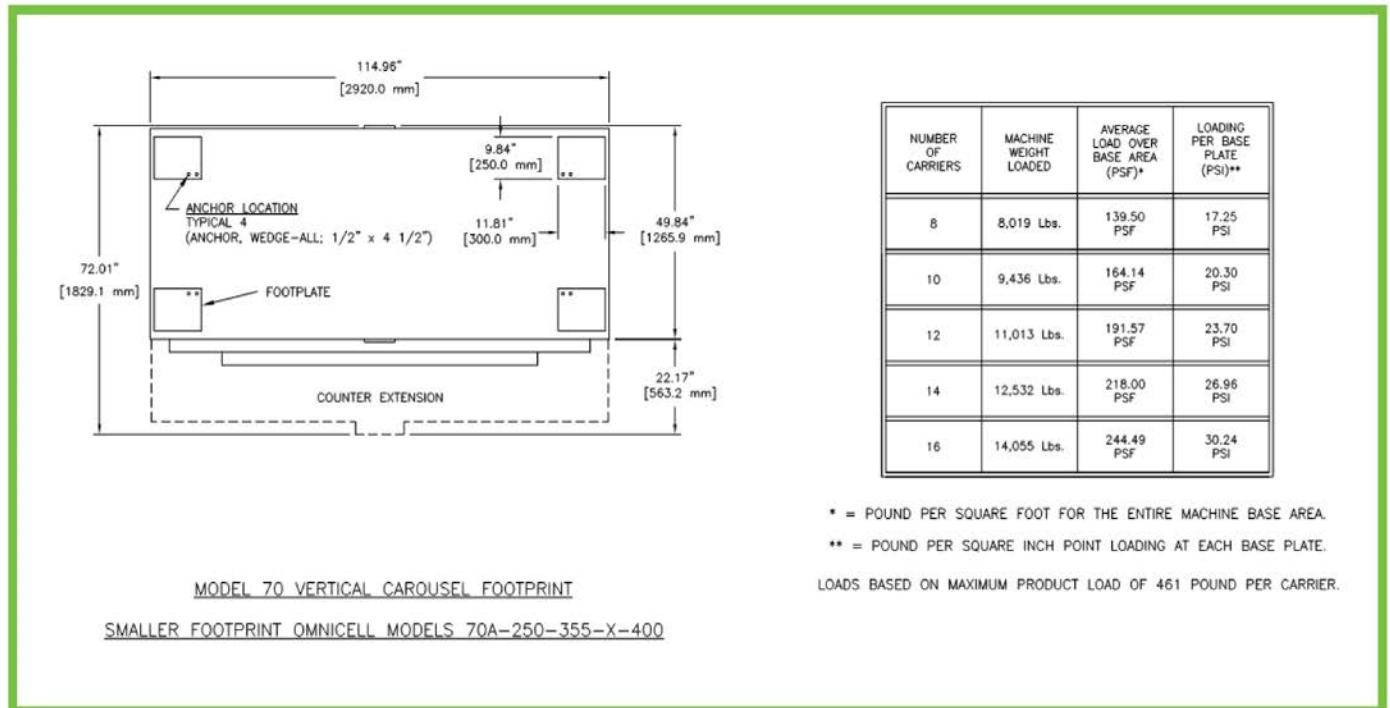

JV Medi Packager Specifications

Approximately three feet of clearance should be allowed around the packager to provide access to the canisters.

The packagers have double doors that open on the front, left, and right sides to allow restocking of canisters. Each single door is approximately 1/2 the size of the side it is in.

The back of the packager has a fan that must be accessible for periodic cleaning and maintenance. To maintain circulation, place the unit away from the wall by 12-20" (or) 30.48 - 50.8 cm.

The floor load range for the JV Medi packager is 106-183 lb/sq. foot (or) 517.54-893.48 kg/sq. m.

Equipment	Specifications	
	Packaging speed:	60 packets/minute
	Canister types:	Medium, large, extra large
	Detection system:	Infrared beam
	Package size:	2.76" x 2.17" (70 mm x 55 mm) (standard)
	Printing system:	Thermal transfer, unlimited fonts
	Input system:	10.4" (26.42 cm) Color Touch screen
	Power use:	200W (maximum 900W)
	Power supply:	120V/60Hz (CSA certified)
		230V, 240V/50Hz (CE certified)
	More details:	See table below.

Model	# of Canisters	Width	Depth	Height	Weight
100BX	100	42.8"/108.71 cm	34.5"/87.63 cm	73.5"/186.69 cm	1080.3 lb /490.06 kg
150BX	150	42.8"/108.71 cm	34.5"/87.63 cm	73.5"/186.69 cm	1080.3 lb/490.06 kg
240BX	240	42.8"/108.71 cm	34.5"/87.63 cm	79.4"/201.68 cm	1344.8 lb/609.63 kg
350SL	350	42.8"/108.71 cm	47.5"/120.65 cm	79"/200.66 cm	2072.3 lb/939.98 kg
400SL	400	42.8"/108.71 cm	47.5"/120.65 cm	85.1"/216.15 cm	2314.9 lb/1050.02 kg

Model	# of Canisters	Width	Depth	Height	Weight
500SL	500	42.8"/108.71 cm	47.5"/120.65 cm	91.2"/231.65 cm	2557.4 lb/1160.02 kg

Yuyama Packager Specifications

Allow sufficient clearance around the packager for access to the canisters, maintenance, and circulation.

The 260 model requires a clearance on the left of 11.8" (29.72 cm.) All models require a rear clearance of 39.3" (100 cm.)

The floor load for the Yuyama packager varies by model:

- [260] 320 lb/145 kg per caster
- [336] 269 lb/122 kg per caster
- [520] 315 lb/143 kg per caster

Equipment	Specifications	
	Packaging speed:	60 packets/minute
	Canister types by model:	36XL, 224L
	Detection system:	Photo sensor
	Package size:	2.36", 2.76", 2.99", 3.15", 3.54" W x 2.76" L / 60, 70, 76, 80, 90 mm W x 70 mm L standard; 1.67" W x 2.36" L
	Printing system:	Thermal transfer, unlimited fonts
	Input system:	10.4" (26.42 cm) Color Touch screen
	Power use:	800 -1,400 V AC (vary by model)
	Power supply:	100V AC- 230V AC; 50-60 Hz

Equipment	Specifications	
	Clearance:	[Back] 39.3" (100 cm)
	More details:	See table below.

Equipment	Specifications	
Packager-336 model	Packaging speed:	60 packets/minute
	Canister types by model:	230XL, 106L
	Detection system:	Photo sensor
	Package size:	2.36", 2.76", 2.99", 3.15", 3.54" W x 2.76" L / 60, 70, 76, 80, 90 mm W x 70 mm L, standard; 1.67" W x 2.36" L
	Printing system:	Thermal transfer, unlimited fonts
	Input system:	10.4" (26.42 cm) Color Touch screen
	Power use:	1,000 V AC (MAX)
	Power supply:	100V AC-230V AC; 50-60 Hz
	Clearance:	[Back] 39.3" (100 cm)
	More details:	See table below.

Equipment	Specifications	
Packager- 520 model	Packaging speed:	60 packets/minute
	Canister types by model:	72XL, 448L
	Detection system:	Photo sensor
	Package size:	2.36", 2.76", 2.99", 3.15", 3.54" W x 2.76" L / 60, 70, 76, 80, 90 mm W x 70 mm L, standard; 1.67" W x 2.36" L
	Printing system:	Thermal transfer, unlimited fonts
	Printer Paper Part Number	95-9003; Paper, Roll, Yuyama Packager
	Input system:	10.4" (26.42 cm) Color Touch screen
	Power use:	1,400 V AC (MAX)
	Power supply:	100V AC-230V AC; 50-60 Hz
	Clearance:	[Back] 39.3" (100 cm)
More details:	See table below.	

Model	# of Canisters	Width	Depth	Height	Weight
260	260	35.04"/89 cm	36.61"/93 cm	78.66"/199 cm	1278.7 lb/580 kg

Model	# of Canisters	Width	Depth	Height	Weight
336	336	50.83"/129 cm	36.61"/93 cm	78.66"/199 cm	1609.4 lb/730 kg
520	520	70.08"/178 cm	36.61"/93 cm	78.66"/199 cm	2513.3 lb/1140 kg

Carousel Peripherals and Options

All user versions communicate with the main application and SQL database on a system server.

- Pick manager (included)
- SATO thermal label printer (included). (For specifications, see ["SATO and HP Laserjet Printer Part Numbers".](#))
- Cordless bar code scanner (CODE 3500) (included)
- Computer monitor (Dell 17" or 43.18 cm flat screen) (included)
- Preventive maintenance: Two times per year with service contract; only Gold Service offered (recommended)
- Licensing (10 licenses) (required)
- Totes - with configurable dividers
 - External Dimensions (H x W x L) 5" x 8.38" x 24"; (12.7 cm x 21.27 cm x 60.96 cm)
 - Internal Dimensions (no dividers) 4.5" x 7.38" x 23"; 11.43 cm x 18.73 cm x 58.42 cm
 - Smallest compartment with dividers: 4.5" x 3.5" x 5.75"; 11.43 cm x 8.89 cm x 14.61 cm
- Options
 - Hand-held computer, symbol MC70
 - Laser printer
 - Small label printer, wired or wireless (Intermec PB50)
 - Software (MobileNet)

Figure 1: Totes (with and without dividers)

Packager Options

- Dispensing tray system (DTA): for extemporaneous packaging; capacity: 60 doses (included)
- White back packaging: Class A packaging paper/printing materials (included)
 - Low-density polyethylene
 - 1 year expiration from the manufactured date (refer to the packaging box for date)
- Standard packaging size: 70 mm x 60 mm or 2.76" x 2.37"
- UPS (included)
- Laser Printer (HP LaserJet or similar, included), or customer-provided (optional)
- Canister calibration (original calibrations included): Calibrated to fit each oral solid (tablet or capsule) by canister calibration specialist.
- Label Printer: SATO M84 Pro 200 dpi (79 dots per cm) or 600 dpi (236 dots per cm) (included)
- Preventive maintenance: Four times per year with service contract; only Gold Service offered (recommended)

OmniLinkRx

OmniLinkRx is a software-only, Web-based physician order management system used to track medication orders within the pharmacy.

Orders can be sent using either digital senders or analog fax machines. The digital image is instantly available to view at both nursing and pharmacy workstations. Facilities running Omnicell 10.0 software or higher can also view orders on designated Color Touch cabinets.

This chapter covers equipment specifications for OmniLinkRx. Common specifications that are shared by all hardware products are in the ["OmniCenter/Color Touch"](#) chapter.

Hardware Specifications

The hardware specifications listed here include servers, the disk sizing tool, workstations, and faxes.

OmniLinkRxServers

OmniLinkRx can be installed as either single server or a multi-site install (one database for multiple sites).

Platform Matrix

For virtual server specifications, see ["Windows 2012 Virtual Machine Configuration"](#)

Server	Hardware	OS	Database	Application	Interface
OmniLinkRx	R320	MS Windows 2012	MS SQL Server 2012	OmniLinkRx	Interfaces Services (on OLRX or stand alone)

Requirements

Table 21: OmniLinkRx Server Requirements

Component	Specification
OS/Platform	Microsoft Windows 2012 Server (64 bit) (new installations). Microsoft Windows 2008 Server, Service Pack 3 (backward compatible).
Microsoft SQL Server	MS SQL Server 2012 , 64-bit platform./2008 Workgroup Edition SP2. Uses default settings with the exception that the data files should be installed on drive D: when prompted; recommend Mixed mode (Windows authentication and SQL server authentication).

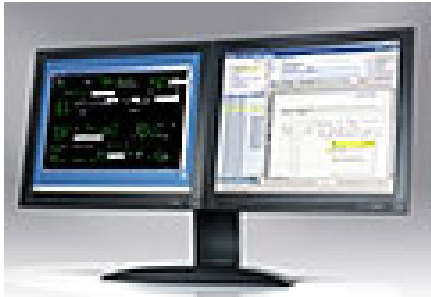
Component	Specification
Computer/Processor	Intel Xeon CPU E5-2630 0 @ 2.30 GHz
RAM	4 GB only.
Hard disks	Must meet minimum hard disks for RAID 1 with RAID 5 (recommended) or meet minimum hard disks for RAID 5. See "OmniLinkRx Disk Sizing Tool" .
RAID	RAID 1 array (two physical drives) for the operating system (logical drive C: minimum 10GB) with RAID 5 array + hot-swap drive (4 + physical drives) for the data (logical drive D:).
Network card	100 MB Minimum. Static IP address.
Media drive	CD-ROM or DVD drive.
Modem (optional)	56KB modem; used as an alternate access for dial-in support if a VPN is not available.
Tape Drive (optional)	Used for data backups to tape; not required if centralized backup system is used.
Display monitor	<p>VGA 1024 x 768 and True Color or higher resolution.</p> 
Peripherals	Keyboard and mouse

Component	Specification
Fax machine (optional) [cards and software for new and existing installations]	Mainpine fax card (new installations). Brooktrout fax card (existing installations). Mainpine IQ Express RF5122 Series 4 Port+ Microsoft FAX. GFI FAXmaker for Exchange/SMTP 12 with Brooktrout (existing installations). [For incoming fax management/routing; customer may purchase from Omnicell for up to 4 lines]. See " OmniLinkRx Faxes " for more information.
Terminal Services Server	For service/support; recommended for secondary remote support even if other remote support is available (such as PcAnywhere). Also recommend Remote Administration mode; use Relaxed Security for Windows 2003 Server.
FTP Server	Required for FTP publishing through IIS. Uses Port 21.
IIS—Web Service	Required for administration and internet publishing service. Uses Port 80.
Anti-virus software	Not included, but strongly recommended; customer choice.

OmniLinkRx Disk Sizing Tool

A disk sizing tool is available in MS Excel format.

A sample is provide below for reference.

Element	Value
Average Document Size (KB)	200
Average number of document pages generated each day	1000
Expected archive period (days)	30
Expected frequency of archiving (days)	60
Number of archives to be kept online before placed on removable media	2

Element	Value
Minimum recommended hard disk space needed for data (Gigabits)	56

Fill in the top cells and the recommended data disk size will be displayed in the bottom cell. Note: The recommended size is for data only. An additional 2GB is required (preferably on separate disks) for the operating system and programs. The average document size used here should reflect the image type (Fax vs. digital-sender) used on site. Quality needs are also a factor. Higher quality = larger image sizes (up to 700KB). The image size should be based on sources type, image complexity, and desired quality.

For a copy of the Disk Sizing tool, contact the Omnicell Project Manager.

OmniLinkRx Workstation Requirements

Client workstations designated to either update or view orders from OmniLinkRx must meet these web browser and PDF XChange Viewer ActiveX system requirements.

Table 22: OmniLinkRx Workstation Requirements

Component	Specification
OS/Platform Microsoft	Windows 7 (32 bit and 64 bit)
Computer/Processor	Pentium 1 GHz processor or faster
RAM	4 GB only
Web Browser	Microsoft Internet Explorer 8.0 - 11.0 (32 bit versions only)
Network card	100 MB minimum
Display	VGA 1024 X 768 resolutions and True Color or higher-resolution monitor; large monitors (>17" or 43.18 cm) are recommended for easy viewing of the images while also viewing the pharmacy information system. A dual monitor card and dual monitors--each capable of the same resolution--are recommended for the pharmacy workstation. Dual monitor cards require special configuration and on-site IT support.



If a client workstation is to be used for Automated Patient Association (APA), it must meet .Net Framework 1.1 requirements.

OmniLinkRx Faxes

Mainpine IQ Express RF5122 Series 4 Port + Microsoft FAX is the supported fax solution for all new OmniLinkRx installations.

OmniLinkRx also supports existing Brooktrout/FAXmaker installations.

Figure 2: OmniLinkRx with a Fax Machine



OmniLinkRx is certified to run with Brooktrout TR1034 Fax Card (for existing installations only), PCI models or Mainpine IQ Express quatro+ fax card (for new installations).



Consult your Omnicell sales representative for pricing and availability of these options. Fax cards are not supported in a virtual machine (VM) environment.

A full-length PCI 32-bit or 64-bit slot with 33 MHz is required to accommodate a Brooktrout fax card.

Recommended cards:

- TR1034+P4-4L, 4 channel fax board
- Mainpine Rockforcequatro+ card

Digital Type Requirements

- Black/white scanning or color scanning (recommended)
- Should not have to be routed through a PC
- Programmable two-button stroke for sending orders
- Network card: 100 MB minimum; Ethernet interface card with TCP/IP support
- Email support: able to send scanned images in TIFF, MTIFF or MTIFF6 file attachments (other image file types also supported)

Analog Type Requirements

- One for each sending location
- Glass scan capability for bar code labels
- Programmable two-button stroke for sending orders

OmniLinkRx Software Requirements

Software requirements for OmniLinkRx are shown here.

- Color Touch 5.7 or higher (Omnicell 10.0 +)
- PDF XChange Viewer ActiveX from Tracker Software

OptiFlex

OptiFlex is a software product for open supply systems, secure cabinets, or a hybrid system. It requires a server and client computers.

OptiFlex Electrical Requirements

The facility provides electrical service of one outlet for each Omnicell control cabinet, auxiliary cabinet, and the Omnicell server site, according to Omnicell specifications. The facility is responsible for all electrical and cabling costs.

All Omnicell control and auxiliary cabinets and Omnicell servers use 115V AC for North America. For all other countries, consult the local electrical authority. All units must be within six feet of an electrical outlet. Omnicell recommends that emergency power be provided to each cabinet.

Table 23: OptiFlex Electrical Requirements

Product	Voltage (VAC)	Certified Amperage	Fused Amperage
One-cell, two-cell, three-cell cabinets	90–250 auto-ranging (AR) 85-264 AR (auxiliary)	2 A at 115V AC ~ 230V AC	6.3 A
Mobile Cart	90 – 260 AR	1.25 A at 115V AC 0.75 A at 230V AC	4 A
Cybernet Panel PC	universal 100 ~ 240V AC, 50-60Hz.; uses 180 Watt AC adapter	19V DC, 9.48A at 240V AC	



Power and data connections are made to frames at the back right of the computer. The one-, two-, and three-cell computers are 51-55" (129.54 - 139.7 cm) from the floor. Half-cell computers are 44-50" (111.76 - 127 cm) from the floor. Omnicell power cords are 15 feet in length (4.57 m).

OptiFlex Communication Requirements

Omnicell primarily operates over TCP/IP and uses HL7 interface standards. Socket, FTP, and MSMQ protocols are also used.

OptiFlex Network Requirements

Omnicell supports network connections between the cabinets and OptiFlex.

To ensure that the Omnicell system can interface properly with the facility network, the facility must provide:

- Category 5 cabling
- Network port and static IP address for each cabinet and server
- Subnet mask addresses, gateway, WNS, and DNS
- LAN: 100 bps or better
- Wireless: 802.11 a/b/g



Omnicell's equipment sits behind the facility's firewall. Network security and speed are based on the facility's network.

The MT 2070 wireless scanner operates with bluetooth technology. The other OptiFlex-compatible scanners are corded. See [OmniCenter/ColorTouch](#). See the *Scanner Matrix Guide* (PN 67-2099) for more information.

OptiFlex Remote Access

Omnicell service requires remote access. These options can be used.

- Omnicell's vSuite with web access over Port 443 (preferred)
- Facility-provided VPN connection

OptiFlex Environment Specifications

OptiFlex Cabinet Transport/Storage Conditions

The maximum cabinet humidity exposure should not exceed 80%. It should be without condensation.

See the recommend cabinet temperature ranges by item type in the table below.

Cabinet	Degrees Celsius	Degrees Fahrenheit
Medications	20-25°	68-77°
General supplies (with brief deviations)	15-30°	59-86°

OptiFlex Heat Dissipation

The back of any Omnicell cabinet must be kept at least 4" (10.16 cm) away from the wall or another cabinet for proper ventilation.

See "[Color Touch Heat Dissipation](#)" for more details.

OptiFlex Safety/Quality Certifications

Omnicell cabinets are CSA and CE certified.

- Omnicell cabinets meet fire protection standards with their CSA and CE certification.
- Omnicell is ISO 9001:2000 compliant.

OptiFlex 11+ Computer Equipment Minimum Specifications

OptiFlex Server Configuration/Database

OptiFlex v11.x is installed as a single server. An additional disaster recovery drive is included.

OptiFlex Platform Matrix

The various platforms used to run OptiFlex are shown here.

Server	Hardware	OS	Database
OptiFlex 14.0	Dell PowerEdge T320	Win2012 (64-bit)	SQL2012
OptiFlex 12.0	Dell PowerEdge T320	Win2012 (64-bit)	SQL2012
OptiFlex 12.0	Dell PowerEdge R320	Win2012 (64-bit)	SQL2012
OptiFlex 11.2	Dell PowerEdge T620	Windows Server 2008 (32-bit) SP1, Standard Edition, Includes 5 CALs	SQL Server 2008
OptiFlex 11.2	Dell PowerEdge R320	Windows Server 2008 (32-bit) SP2, Standard Edition	SQL Server 2008

OptiFlex Inventory Control Module Computers

Specifications for the Inventory Control Module computers are shown here.

	Minimum Requirement	Recommended
Processor	Pentium 4 class, 4GHz	Intel Core Duo E8400 @ 3.00 Ghz
Memory	2 GB RAM	4 GB RAM
Hard Drive	50 GB	500 GB provided with Cybernet
OS	32-bit Windows XP Service Pack 3	Windows 7 (32-bit)
Network Interface Card	10/100	1000
Laser Printer	available	available
USB port	1 for scanner, 1 for label printer	1 for scanner, 1 for label printer
Serial port	1 if portable data collector option selected	1 if portable data collector option selected

Inventory Control Module computers must meet the following minimum specs:

- Pentium 4 class processor, 4GHz
- 2 GB RAM Minimum, 4 GB RAM recommended
- 50 GB hard drive
- Windows 7 preferred; Windows XP Service Pack 3 supported
- Network Interface Card
- Color Monitor
- Available Laser Printer
- 1 Available USB port for scanner
- 1 Available USB port for label printer (if label printer to be used at the computer)
- 1 Available serial (if portable data collector option selected)

OptiFlex Point of Use Computers

OptiFlex Point of Use computers must meet the minimum specifications shown here.

For Med/Surg Software

	Minimum Requirement	Recommended
Processor	Pentium 4 class, 1GHz	Intel Core Duo E8400 @ 3.00 Ghz
Memory	256 MB RAM	4 GB RAM
Hard Drive	150 GB	500 GB provided with Cybernet
OS	32-bit Windows XP Service Pack 3	Windows 7 (32-bit)
Network Interface Card	10/100	1000
Touch Screen Monitor	800 x 600 resolution	800 x 600 resolution
Laser Printer	available	available
USB port	1 for keyboard 1 for touch-screen monitor, if not using all-in-one computer with integrated touchscreen 1 USB synapse interface for scanner	1 for keyboard 1 for touch-screen monitor, if not using all-in-one computer with integrated touchscreen 1 USB synapse interface for scanner
Multi-Media	Sound card and speakers	Sound card and speakers

- Pentium 4 class processor, 1GHz Minimum, 2GHz recommended
- 2 GB RAM recommended, 256 MB RAM minimum
- 150 GB hard drive
- Windows 7 preferred; Windows XP Professional Service Pack 3 supported
- Network Interface Card
- USB Keyboard Port
- Touch screen color monitor set to 800 X 600 resolution
- 2 Available USB ports 1 for each of the following accessories:
- USB Touch screen monitor if not using all-in-one computer with integrated touchscreen
- USB Synapse interface for scanner
- Multi-Media (Sound card and speakers)

For Cath Lab and Surgical Services Software

	Minimum Requirement	Recommended
Processor	Pentium 4 class, 2GHz	Intel Core Duo E8400 @ 3.00 GHz
Memory	256 MB RAM (for CL) 1 GB RAM (for SS)	4 GB RAM
Hard Drive	150 GB	500 GB provided with Cybernet
OS	32-bit Windows XP Service Pack 3	Windows 7(32-bit)
Network Interface Card	10/100	1000
Color Monitor	800 x 600 resolution	800 x 600 resolution
Laser Printer	available	available
USB port	1 for keyboard 1 USB synapse interface for scanner	1 for keyboard 1 USB synapse interface for scanner
Multi-Media	Sound card and speakers	Sound card and speakers

- Pentium 4 class processor, 2GHz
- 2GB RAM recommended, minimum for CL is 256 MB; minimum for SS is 1GB
- 150 GB hard drive
- Windows 7 or Windows XP Professional Service Pack 3
- Network Interface Card
- USB Keyboard Port
- Touch screen color monitor set to 800 X 600 resolution
- 1 Available USB ports for USB Synapse interface for scanner
- Multi-Media (Sound card and speakers)

Optiflex 12.0 Servers

All Omnicell servers use the same models and specifications.

See "[Omnicell Server Configuration](#)". The configuration and data base may vary.

OptiFlex Client Hardware/Software

OptiFlex uses the Universal Cybernet AIO.

- Universal Cybernet AIO workstation specifications are found in ["Appendix C: Cybernet iOne H19 Workstation Specifications"](#).

OptiFlex Cabinet Specifications

OptiFlex software can work with open systems (shelves/bins), closed systems (with Omnicell cabinets) or hybrid systems.

The cabinets used for the closed configurations of OptiFlex are the: Color Touch and auxiliary one-cell, two-cell, three-cell, and half-cell cabinets. The cabinet storage capacity is directly proportionate to the square footage of floor space required for each column. Clearance is required for supply doors and pharmacy drawers. Allow 4-6" (10.16 - 15.24 cm) clearance behind each cabinet for ventilation. Supply shelves are 22.75" (57.79 cm) wide by 21-22" (53.34 - 55.88 cm) deep.

The following contains applicable cabinets with OptiFlex modules. For more detailed specifications, see ["Omnicell Cabinet Space Requirements"](#).

Cabinet Type	Omnicell Supply Specialty Model #
One-cell cabinet	OPF-FRM-001
One-cell auxiliary	OPTIX1
Two-cell cabinet	OPF-FRM-002
Two-cell auxiliary	OPTIX2
Three-cell cabinet	OPF-FRM-003
Three-cell auxiliary	OPTIX3
Omnicell Supply Specialty Mobile Cart	OPF-FRM-004
Half cell auxiliary	OPTIXH

Supply Modules

OptiFlex software works with these Omnicell supply modules.

- Magnetic Card Reader (refer to the *Omicell/OptiFlex Card Reader Installation and Configuration Guide*(P/N 67-2006) for system requirements).
- Supply Drawers (see "[Omicell Cabinet Module Specifications](#)").
- Catheter Rack (see "[Omicell Cabinet Module Specifications](#)").
- Suture Rack (see "[Omicell Cabinet Module Specifications](#)").
- Pull-out Shelf (see "[Omicell Cabinet Module Specifications](#)").
- Wireless Bar Code Scanner (see "[Omicell Cabinet Module Specifications](#)").

OptiFlex Scanner Mount

The OptiFlex scanner mount can only be mounted on the right side of main cabinets; the mount adds an additional 5.25" (13.34 cm) to the cabinet width.

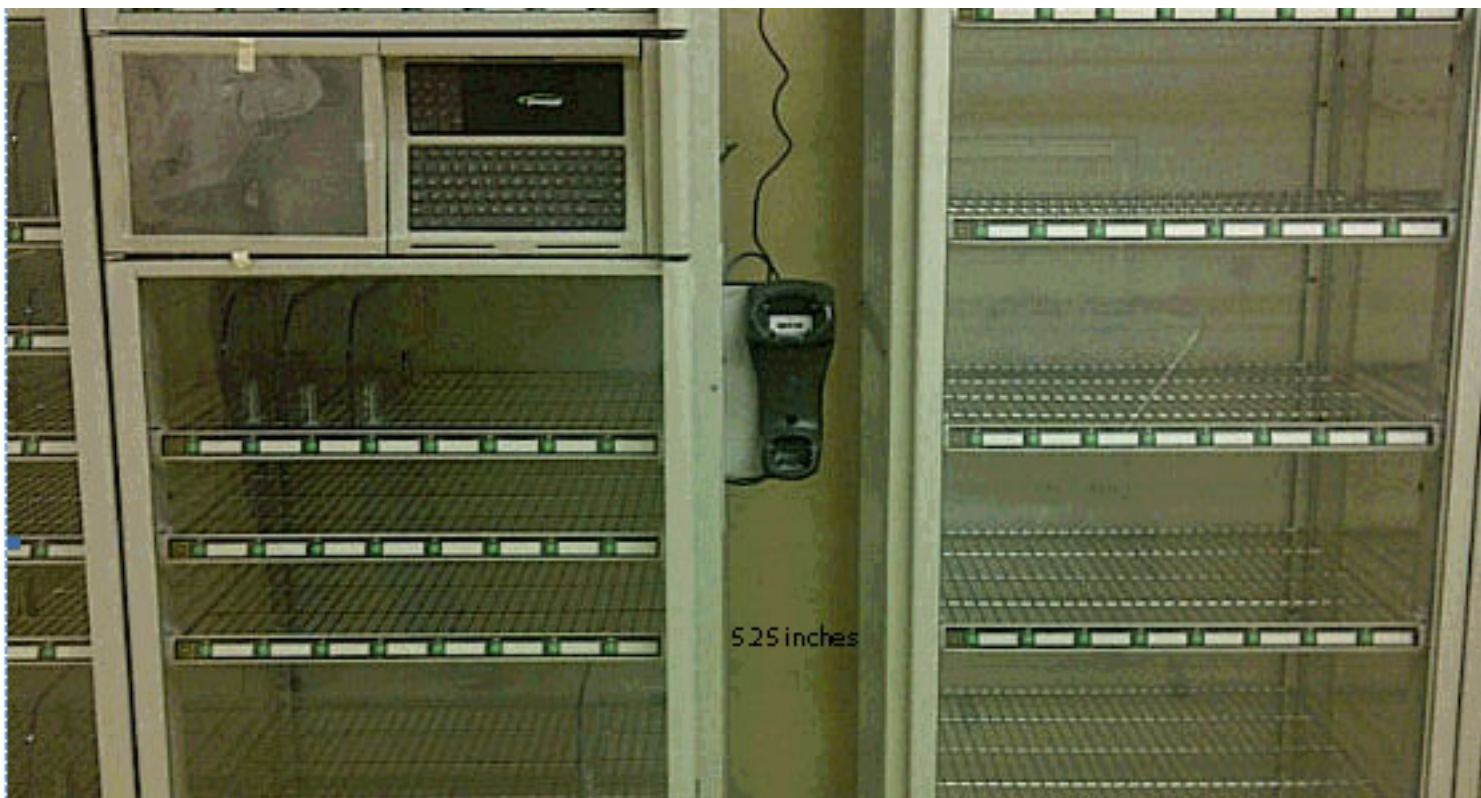

SecureVault

The SecureVault cabinet is an automated dispensing machine for controlled substances that has been superseded by CSM.

This chapter covers equipment specifications for SecureVault. CSM specifications are in the ["CSM"](#) chapter. Common specifications that are shared by all hardware products are in the [OmniCenter/ColorTouch](#) chapter.

Figure 3: SecureVault



SecureVault Server Configuration

SecureVault is installed as a single server.

Platform Matrix



Server	Hardware	OS	Database	Application	Interface
SecureVault	Workstation	MS Windows 2003 Server	FoxPro	SecureVault	Interfaces Services (on OmniCenter or stand alone)

Requirements



While the recommended minimum requirements may be adequate for most sites, the facility may have further requirements for additional or higher-performance hardware. Omnicell is committed to ongoing system improvement; these specifications are subject to change. Please contact Omnicell for the latest requirements.

Component	Specification
Computer	Pentium-4 2.40 GHz or faster
Minimum RAM	2 GB or greater
Minimum Hard Disk Available Capacity	80 GB available fixed disk or greater (allocate 240 MB plus 6 MB for every 10,000 historical records retained)
Monitor	Color monitor 1024 x 768 resolution. 17" (43.18 cm) flat panel recommended; touch screen optional
Mouse	Standard: mouse, touchpad/track ball with appropriate drivers
Keyboard	Standard: detachable keyboard
Bar Code Scanner	Symbol LS 4208
Removable Media Drive	CD-ROM (48x or greater)
Communications Port - Ethernet	Network Ethernet connection with static IP address required for connection to SecureVault cabinet (if present) and OmniCenter server interfaces
Hub/Switch	Network interconnections if network response times are slow
Remote Support Software	Remote control software (vDirector, pcAnywhere, DameWare, Remote Administrator, etc.)

Component	Specification
Remote Support 1. Modem & DID line 2. VPN	1. vDirector Omnicell Remote Monitoring and Connectivity package (preferred) 2. Direct inward dial (DID) analog telephone connection & 56K Modem 3. VPN internet connection (customer provides VPN client software)
Printer Port	Centronics parallel and/or free USB port for local printer (standard or EEP; not ECP)
Printer	1. Standard laser printer (300 dpi [118 dots per cm] or greater) 2. Parallel or USB port operation recommended for local operation 3. Network printing supported (printer should be conveniently located to SecureVault) 4. 8.5" x 14" (21.59 cm x 35.56 cm) paper tray recommended if that is the size of the Usage Forms that are used
Backup Device	Default backup is to OmniCenter shared drive; if other backup process desired, customer provides hardware and software (e.g. backup to network, tape drive or zip drive)
Operating System	Windows XP Professional recommended (Windows 2000 Professional acceptable) <hr/>  At least one pharmacy user should have local administrative rights to load software, install printers, change resolution, etc.
Software	1. Microsoft Office XP or 2003 (recommended) 2. MS Word for viewing/creating supplemental documentation 3. Adobe Acrobat Reader for viewing supplemental documentation
Ethernet Connectivity & I.P. Address	1. Two Ethernet Jacks required—for SecureVault cabinet and SecureVault PC; two static IP addresses required; need default router and subnet info <hr/>  If this is a software-only installation (no cabinet), only one ethernet jack and IP address needed
Uninterrupted Power Supply (UPS)	Highly recommend 750 VA UPS for the SecureVault PC and 500 VA UPS for each SecureVault OmniSupplier and/or auxiliary cabinet to avoid database corruption and operating system failures in event of power outages



SecureVault cannot be upgraded beyond software version 18.0 due to NetJet EOL/EOS.

Anywhere RN

Anywhere RN is a licensed feature allowing users, with privileges, the ability to create requests for medication issues and returns, and document wastes from a remote location. Anywhere RN is available embedded with Epic Hyperspace®.

This chapter covers equipment specifications for Anywhere RN™. Common specifications that are shared by all hardware products can be found in the [OmniCenter/ColorTouch](#) chapter.

Anywhere RN System Requirements

Anywhere RN is only available when licensed.

- Login in is not allowed if not licensed.
- Login is not allowed if the number of licensed concurrent users is exceeded.
- Login is not allowed if the user does not have the privilege to access Anywhere RN.

To implement the software features discussed in this book, minimum requirements must be satisfied for the OmniCenter/server, the Color Touch cabinet, and the remote workstation network.

Anywhere RN OmniCenter/Server Minimum Requirement

There are minimum server requirements for direct software upgrade. No direct hardware/server upgrades from Windows 2000 are supported. However, if a server swap is required, Omnicell will assist in the upgrade of customer data.

For more information, see the *Hardware/Software Compatibility Matrix* (PN 67-2127).

Minimum server requirements are:

- G4: Server running version 15 or higher and Windows 2008 or higher
- G3: Server running version 14 or higher and Windows 2003 or higher

Anywhere RN Color Touch Cabinet Minimum Requirements

These are minimum Color Touch requirements.

Color Touch G4 cabinets running:

- Microsoft Windows 7 (32-bit or 64-bit) with SP1
- Color Touch 15.0

OR

Color Touch G3 cabinets running

- Microsoft Windows XP SP 3
- ETX motherboard
- CT version 5.10 (version14)

Sure-Med cabinets are not supported for upgrade.

Anywhere RN Remote Workstation Network Requirements

Anywhere RN has these remote workstation requirements.

- Microsoft Internet Explorer 8.0, 9.0, 10.0, or 11.0.
- 32-bit or 64-bit Windows operating system capable of supporting Internet Explorer 7 (only pre-18.0), 8, 9, 10, or 11.



The Savvy Mobile Management Workstation 18.0 supports Internet Explorer 8.0 or 9.0.

System requirement link path:

<http://www.microsoft.com/windows/internet-explorer/support/system-requirements.aspx>

- Connected to a network with access to the OmniCenter server
- Reliable network with a minimum of 54 Mbps; 100 Mbps or higher is preferable

Minimum Requirement

- Microsoft Internet Explorer 7.0 (IE7 for pre-18.0, IE8 for 18.0 and later)
- 32-bit or 64-bit Windows operating system capable of supporting Internet Explorer 7.0 (for versions before 18.0) or Internet Explorer 8.0 or later (for 18.0 and later versions).

System requirement link path:

<http://www.microsoft.com/windows/downloads/ie/sysreq.msp>

Anywhere RN Interfaces

No new interfaces are introduced with Anywhere RN. Standard interfaces and service policy apply.

New customer servers are installed with interface services. Existing customers are supported by Omnicell interface services and classic interfaces.

As always, Operations must contact an Interface Analyst before scheduling installation as some Omnicell 15.0 features might impact interfaces.

Anywhere RN Remote Workstation Requirements

When installed and properly configured, users can connect to the Anywhere RN application from any facility computer simply by using an Internet Explorer (IE) browser window.

IE 7.0 or IE 8.0 browser is employed by Anywhere RN using Omnicell 15.0. More up to date versions of OmniCenter support the latest versions of Internet Explorer.

Recommended Configurations

- Browser display of 800 x 600 optimal (full screen). Not supported on handheld device.
- Add OmniCenter Server IP to the local Intranet sites in IE.

- IE should allow pop-ups from the OmniCenter server (for full windowed version - handled if the OmniCenter is part of the local intranet). Also recommend Open popups in new window tabs setting.
- IE should not remember passwords.
- IE should not remember data entered into input boxes.

Anywhere RN Mobile Cart Requirements

A wireless internet connection is required for Anywhere RN users to perform any remote workflows from a mobile cart.

Omnicell Mobile Cart Systems

Omnicell Savvy Mobile Medication Workstation carts used for dispensing medication must have:

- Omnicell created boards/firmware
- Omnicell created cart software which contains, but is not limited to:
 - battery management
 - drawer management
 - cart administration

For more information about the functions of Omnicell mobile cart systems, refer to the *Savvy Mobile Medication Workstation Implementation Guide*, PN 67-2081.

Anywhere RN Security Notes

Access to the Anywhere RN application requires Omnicell user access.

- Access rights are defined and managed within the OmniCenter.
- The Anywhere RN web application uses the local hospital intranet.

Anywhere RN Network Notes

Any interruptions in network communications between OmniCenter and the hospital workstation (remote location) will prevent users from accessing the Anywhere RN application and users will not be able to perform remote tasks.

When OmniCenter is down, the cabinet still functions without updates, but users will not be able to perform remote tasks with the Anywhere RN application.

CSM

The Omnicell Controlled Substance Manager (CSM) system enables the hospital pharmacy to safely and efficiently manage controlled substance inventory in the pharmacy and throughout the hospital.

In the pharmacy, CSM manages controlled item inventory stored in an Omnicell auxiliary (aux) cabinet, on storage shelves or racks, or in a combination of storage locations.

Special interfaces are not needed, as CSM runs on the OmniCenter system, in the same way as other Omnicell cabinets throughout the hospital.

This chapter covers equipment specifications for CSM. Common specifications that are shared by all hardware products are in the [OmniCenter/ColorTouch](#) chapter. The *CSM Implementation Guide* provides a functional overview and implementation instructions.

Figure 4: CSM



CSM Parts List

CSM system part numbers are listed here.

CSM-AIO-001	CSM Software and Workstation Kit (Contains AIO)
CSM-FRM-001	One Cell CSM AUX
CSM-FRM-002	Two Cell CSM AUX
CSM-FRM-003	Three Cell CSM AUX
CSM-FRM-007	Metal Door, One Cell CSM AUX
CSM-FRM-008	Metal Door, Two Cell CSM AUX
CSM-AIO-009	Metal Door, Three Cell CSM AUX
CSM-AIO-002	HW Conversion Kit, SV/NV Blue, CSM Software and Workstation
CSM-AIO-003	HW Conversion Kit, SV/NV CT, CSM Software and Workstation
CSM-OPT-001	Hardware Conversion Narc Vault AUX to CSM AUX Cabinet
CSM-AIO-005	CSM Satellite Installation (Contains AIO), Up to 4 Locations
CSM-SCN-001	Symbol MT2070 2D Barcode Scanner, CSM
CSM-PNT-001	SATO M84Pro(2) Label Printer
OCFLTCK	FlexLock
OSD24	Omicell Supply Drawer
PS1	Pull-Out Shelf
UPS	CDW Tripp Lite Smart 1500VA SLT Tower UPS with AVR

CSM Electrical Requirements

The facility provides electrical service of one outlet for each Omnicell control auxiliary cabinet, scanner, UPS, and the Omnicell server site, according to Omnicell specifications. The facility is responsible for all electrical and cabling costs.

All Omnicell control and auxiliary cabinets and Omnicell servers use 115V AC for North America. For all other countries, consult the local electrical authority. All units must be located within six feet of an electrical outlet. Omnicell recommends that emergency power be provided to each cabinet.

Table 24: CSM Electrical Requirements

Product	Voltage (VAC)	Certified Amperage	Fused Amperage
One-cell, two-cell, three-cell auxiliary	950 - 250 auto-ranging (AR)	2A at 115V AC ~ 230V AC	4 A
Cybernet All-in-One PC	universal 100 ~ 240V AC, 50-60Hz; uses 180 Watt AC adapter	19V DC, 9.48 A at 240V AC	
SATO M84Pro(2) printer	115V / 220V ($\pm 10\%$), 50 / 60 Hz ($\pm 1\%$) (Jumper switch required)	3 A (115V) / 1.5A (220V)	



Power and data connections are made to frames at the back right of the computer. The one-, two-, and three-cell cabinets are 51-55" (129.54 - 139.7 cm) from the floor. Omnicell power cords are 15' in length (4.57 m).

CSM Communication Requirements

Omnicell primarily operates over TCP/IP and uses HL7 interface standards. Socket, FTP, and MSMQ protocols are also used.

CSM Network Requirements

Omnicell supports network connections between the cabinets and CSM. The facility must provide these requirements to ensure that the Omnicell system can interface properly with the facility network.

- Category 5 cabling or better
- Network port and static IP address for each cabinet and server
- Static IP address for the MT2070 scanner
- Subnet mask addresses, gateway, WNS, and DNS

- LAN: 100 bps or better



Omnicell's equipment operates behind the facility's firewall. Network security and speed are based on the facility's network.

CSM Remote Access

Omnicell service requires remote access. The options that can be used are described here:

- Omnicell's vSuite with web access over Port 443 (preferred)
- Facility-provided VPN connection

CSM Environment Specifications

CSM Transport/Storage Conditions

The maximum cabinet humidity exposure should not exceed 80%. No condensation should be present.

See the recommended cabinet temperature ranges by item type in the table below.

Cabinet	Degrees Celsius	Degrees Fahrenheit
Medications	20°-25°	68°-77°
General supplies (with brief deviations)	15°-30°	59°-86°

CSM Heat Dissipation

The back of any Omnicell cabinet must be separated at least 4" (10.16 cm) from the wall or another cabinet for proper ventilation.

See ["Color Touch Heat Dissipation"](#) for more details.

CSM Safety/Quality Certifications

Omnicell cabinets are CSA and CE certified.

- Omnicell cabinets meet fire protection standards with their CSA and CE certification.
- Omnicell is ISO 9001:2000 compliant.

CSM Hardware Specifications

All Omnicell servers use the same models and specifications.

See "[Omnicell Server Specifications](#)". The configuration and database may vary.

CSM Platform Matrix

Server	Hardware	OS	Database	Application
OmniCenter	R320/T320 + extra drive	MS Windows 2012 or 2008 Server	MS SQL Server 2012 or 2008	OmniCenter 15.x, 16

Software/Hardware

- Network drops (one each) for the Cybernet, the printer, the scanner, and the SATO label printer, if applicable.
- Universal AIO workstation: specifications are found in "[Appendix C: Cybernet iOne H19 Workstation Specifications](#)".
- CSM application build
- Available Laser Printer
- 1 Available USB port for scanner
- 1 Available USB port for label printer (if label printer to be used at the computer)
- 1 Available serial port (if portable data collector option selected)

CSM Cabinet Specifications

CSM software can work with closed systems as well as with open shelf-cabinet hybrid inventory.

The cabinets used for the closed configurations of CSM are the auxiliary one-cell, two-cell, and three-cell cabinets. The cabinet storage capacity is directly proportional to the square footage of floor space required for each column. Clearance is required for supply doors and pharmacy drawers. Allow 4-6" (10.16-15.24 cm) clearance behind each cabinet for ventilation.

The following contains applicable cabinets with CSM modules. For more detailed specifications, see "[Omnicell Cabinet Space Requirements](#)".

Cabinet Type	Omnicell Supply Specialty Model Number
One-cell auxiliary	CSM-FRM-001
Two-cell auxiliary	CSM-FRM-002
Three-cell auxiliary	CSM-FRM-003

Optional Metal Cabinet Exterior and Dividers

CSM with metal doors is limited to 1/3 doors only (no full or 2/3 doors). No external guiding lights are visible. The console indicates which door to open. The guiding lights are visible after the door is open.

This table lists the additional weights of the optional metal cabinet exterior and dividers for CSM.

Cabinet Type	Weight
One-cell CSM	35 lb (15.88 kg)
Two-cell CSM	72 lb (32.66 kg)
Three-cell CSM	109 lb (49.44 kg)

The CSM supports two expired item bins, allowing for separate management of expired control level 2 medications.

CSM Supply Modules and Peripherals

CSM software works with the Omnicell supply modules and peripherals listed here.

- Supply drawers (see ["Omnicell Cabinet Module Specifications"](#))
- Pull-out shelves (see ["Omnicell Cabinet Module Specifications"](#))
- Label printer SATO M84Pro, CSM-PNT-001
- FlexLock (see ["Omnicell Cabinet Module Specifications"](#)).

SATO Label Printer Specifications

These are specifications for the optional SATO M84Pro(2) Label Printer.

Table 25: SATO M84Pro(2) printer specifications

Model Number:	M84 Pro(2)
Printing Method:	Direct Thermal / Thermal Transfer
Memory:	<ol style="list-style-type: none"> 1. 16 MB Standard RAM 2. 2 MB Standard Flash 3. 4 MB Flash - Optional 4. 1 MB or 256k PCMCIA - Optional

Print Resolution:	203 dpi (8 dpmm)
Printing Speed:	10 ips (254 mm/s)
Media Width:	Max. 5" (128 mm) / Min. 0.87" (22 mm)
Max. Print Width:	4.1" (104 mm)
Min. Print Length:	<ol style="list-style-type: none"> 1. 0.24" (6 mm) - continuous 2. 0.63" (16 mm) - tear off 3. 1.18" (30 mm) - cutter/dispenser
Max. Print Length:	49.2" (1249 mm)
Max. Ribbon Size:	4.4" (111 mm) W x 1475' (450 m) L - Face-In
Processor	32-BIT RISC
Software	Windows Drivers (Windows® 2000, XP, 2003, Vista and 32-bit Windows 7)
Environment	<ol style="list-style-type: none"> 1. Operating: 41° F to 104° F (5° C to 40° C); 15-85% RH, non-condensing 2. Storage: 23° F to 140° F (-5° to 60° C); Maximum 90% RH, non-condensing 3. EDS: 8kv
Electrical Requirements	115V / 220V (± 10%), 50 / 60 Hz (± 1%) (Jumper switch required)
Agency Certifications	CE, UL, CSA, TÜV
Bar Code Symbologies	<ol style="list-style-type: none"> 1. Elementary: UPC-A, UPC-E, EAN-8, EAN-13, Code 39, Code 93, Code 128, Codabar, MSI, Bookland, Industrial 2 / 5, Interleaved 2 / 5, Matrix 2 / 5, Postnet, GS1-128, GS1-DataBar 2. 2-Dimensional: PDF417, Micro PDF417, Truncated PDF417, Maxicode, Data Matrix, QR Code, Composite Symbology

Barcode and Font Formatting	360° rotation of barcodes and text, character expansion horizontally and vertically, sequential numbering, form overlay for high-speed editing of complex formats.
Dimensions	10.4" W x 17.1" D x 13.4" H (265 mm W x 435 mm D x 341 mm H)
Weight	39.7 lb (18 kg)

PandoraVIA Hardware Specifications

The PandoraVIA suite of analytics software delivers practical tools for analyzing medication distribution. Pandora reports help healthcare facilities with diversion prevention, regulatory compliance, and inventory optimization. Specifications, including supported vendors, upgrades, and configurations, are provided below.

Background Information

- The Application Server is the core of the analytics engine.
- Software licenses require continuous Internet access for the Application Server.
- Pandora 18.0 can be run via Citrix XenApp 6.x.
- For the Application Server, user access is configured via Active Directory by Microsoft.
- Reports are scheduled and sent to the Pharmacy/Nursing/Material Management community through SMTP (MS Exchange).
- DOB and db_creator privileges are required to take advantage of archiving and installation.
- If using a stand-alone server, disk must be partitioned into 2 logical drives with the application installed on the primary drive, and the database installation and database files on the second drive.
- Consider scheduling reports during off-hours.
- Application supports 10-20 concurrent users, based on available hardware.
- Windows 2003, Windows XP, Windows 7 (32-bit) server installs are not supported for 18.0 version of Pandora.
- Over time, Pandora can generate a very large sum of data; using a virtual server enables on-demand addition of resources.

Supported ADS Vendors

- Pyxis 4000
- Pyxis ES (using custom interface)
- Intellidot
- McKesson
- Omnicell Optiflex (10.x or higher)
- Omnicell WorkFlow Rx (6.x or higher)
- Omnicell Omnicenter (14.x or higher)
 - AWS
 - CSM
 - ColorTouch

Supported Upgrades (Starting 18.x)

- 3.0 Clinicals
- 3.6 HF1 Clinicals/Financials/Clinicals+Financials
- 3.7 Clinicals/Financials/Clinicals+Financials
- 4.x Clinicals/Financials / Clinicals + Financials

> 300 beds or > 5 million tx/year

- **OS:** Windows 2008 R2
- **SQL:** Microsoft SQL Server 2008 Standard (64-bit)
- **SQL cap:** 10GB SQL server install and data on D:\

- **Software:** .NET 3.5 SP1, MS Report Viewer 2008 SP1+
- **RAM:** 16GB or more 64Kb file-size cluster for data partition

(For existing customers with a Distributed Server setup):

- App Serv. RAM: 8GB or more
- DB Serv. RAM: 10GB or more
- CPU and Hard Disk: As above

Physical Machine

- **CPU:** 3.0 GHz or higher processor with 4-cores (Ref: E5-2637v2)
- **Hard Drives:** 8 drives, each with 15k rpm and 146GB RAID 10 single-disk array with 2 partitions: C:\ >100GB, D:\ >300GB

Virtual Machine:

- Disk C: 150GB or more, D: 200GB or more
- CPU: 4 vCPU or more

> 600 beds or > 9 million tx/year

- **OS:** Windows 2008 R2
- **SQL:** Microsoft SQL Server 2008 Standard (64-bit)
- **SQL cap:** 20GB SQL server install and data on D:\
- **Software:** .NET 3.5 SP1, MS Report Viewer 2008 SP1+
- **RAM:** 32GB or more 64Kb file-size cluster for data partition

(For existing customers with a Distributed Server setup)

- App Serv. RAM: 12GB or more
- DB Serv. RAM: 20GB or more
- CPU and Hard Disk: As above

Physical Machine

- **CPU:** 3.0 GHz or higher, 2 processors with 4-cores each (Ref: E5-2637v2)
- **Hard Drives:** 12 drives, each with 15k rpm and 146GB RAID 10 single-disk array with 2 partitions: C:\ >200GB, D:\ >500GB

Virtual Machine:

- Disks: C:\ 150GB or more, D:\ 400GB or more
- CPU: 8 vCPU or more

Client Tier Specifications

The Pandora client application can be installed on laptops, virtual machines, and can cohabit with other applications. If sharing a workstation with other data-sensitive software, it may be advisable to increase RAM.

- OS: Windows 7, Windows XP
- RAM: 4GB or higher
- CPU: 2.3Ghz or higher (Dual Core)
- Disk Space: 50GB or more

Appendix A: Read Height

Bar code reading is done from the bottom of the card to the middle of the bar code. Omnicell offers two bar code reading heights (0.4 inches [1.02 cm] and 0.49 inches [1.24 cm]).

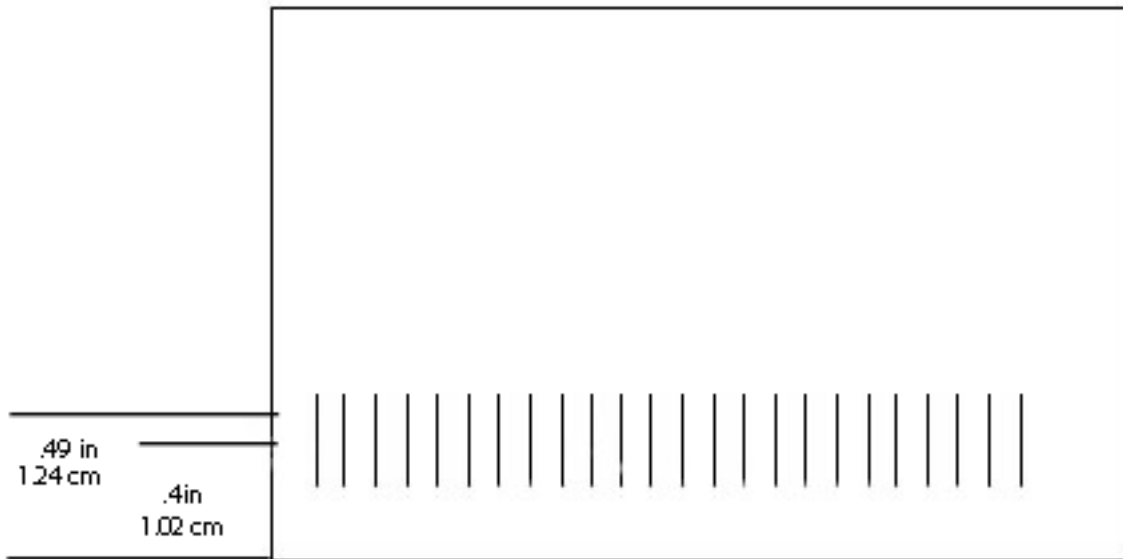

The figure below does *not* provide exact measurements. It is only a guide for orientation. The bar code measurement must be performed using a typical card that is used by the facility.

Figure 5: ID card example



Appendix B: Seismic Specifications

This section contains the 2007 Seismic Specifications for the OmniRx, and 1-2-3-cell cabinets, and the Yuyama packager. These were produced by Degenkolb Engineers and approved by the state of California.

<p>OMNICELL OSHPD PRE-APPROVAL OF MANUFACTURER CERTIFICATION OPM 0185-13 OMNI-SUPPLIER ONE-, TWO-, AND THREE-CELL CABINETS</p>	 <p>Degenkolb DEGENKOLB ENGINEERS 235 Montgomery Street, Suite 500 San Francisco, CA 94104 415.392.6952 Phone 415.981.3157 Fax www.degenkolb.com</p>	
<p>OMNI-SUPPLIER ONE-CELL CABINET MODELS OS104, OSC104, MDA-FRM-001, MDA-FRM-001-CI, MSA-FRM-001-INT, NAC-FRM-004, NAC-FRM-005, NAC-FRM-009, NAC-FRM-010, OPF-FRM-001, SDA-FRM-001, CSM-FRM-004-INT, CSM-FRM-007, OPTIX1, OX104, OX104-INT, OX104RX, OX104SV</p>	<p>OMNI-SUPPLIER TWO-CELL CABINET MODELS OS224, OSC224, MDA-FRM-002, MDA-FRM-002-CI, MSA-FRM-002-INT, NAC-FRM-005, NAC-FRM-006, NAC-FRM-007, NAC-FRM-008, OPF-FRM-002, SDA-FRM-002, CSM-FRM-002, CSM-FRM-005-INT, CSM-FRM-008, OPTIX2, OX224, OX224-INT, OX224RX, OX224SV</p>	<p>OMNI-SUPPLIER THREE-CELL CABINET MODELS OS344, OSC344, MDA-FRM-003, MDA-FRM-003-CI, MSA-FRM-003-INT, OPF-FRM-003, SDA-FRM-003, CSM-FRM-003, CSM-FRM-006-INT, CSM-FRM-009, OPTIX3, OX344, OX344-INT, OX344RX, OX344SV</p>

GENERAL NOTES:

1. THIS OSHPD PRE-APPROVAL OF MANUFACTURER'S CERTIFICATION (OPM) IS BASED ON THE CBC 2013. THE DEMAND (DESIGN FORCES) FOR USE WITH THIS OPM SHALL BE BASED ON THE CBC 2013.
2. PRE-APPROVED DESIGN AND MATERIALS CONFORM WITH THE 2013 EDITION OF THE CALIFORNIA BUILDING CODE. DETAILS WITHIN THIS APPROVAL MAY BE USED ANYWHERE IN THE STATE OF CALIFORNIA WHERE $S_{ps} \leq 1.85$.
3. SEISMIC FORCES ON EQUIPMENT DETERMINED PER THE 2013 CBC & ASCE 7-10 SECTION 13.3. ALL LOADS IN THIS PRE-APPROVAL ARE AT STRENGTH LEVEL AND SHALL BE USED FOR STRENGTH DESIGN.
 CASE 1 (EQUIPMENT ABOVE GRADE TO ROOF): $S_{ps} \leq 1.85$, $op=1.0$,
 $R_p=1.5$, $I_p=1.5$, $\Omega_0=1.5$, $z/h \leq 1.0$
 i. $F_p=2.22W_p$, $F_v=0.37W_p$
 CASE 2 (EQUIPMENT AT OR BELOW GRADE): $S_{ps} \leq 1.85$, $op=1.0$, $R_p=1.5$,
 $I_p=1.5$, $z/h = 0.0$, $\Omega_0=1.5$
 i. $F_p=0.83W_p$, $F_v=0.37W_p$
4. THE STRUCTURAL ENGINEER-OF-RECORD (S.E.O.R.) IS RESPONSIBLE FOR THE FOLLOWING:
 - a. VERIFY THAT THE ANCHORS ARE AN ADEQUATE DISTANCE FROM ANY SLAB OPENINGS OR EDGES.
 - b. VERIFY THAT THE ANCHORS ARE AN ADEQUATE DISTANCE FROM ANY NEW OR EXISTING ANCHORS.
 - c. DESIGN ANY SUPPLEMENTARY MEMBERS AND THEIR ATTACHMENTS WHICH THE UNIT IS ANCHORED TO. VERIFY THE ADEQUACY OF ANY EXISTING MEMBERS AND THEIR ATTACHMENTS WHICH THE UNIT IS ANCHORED TO FOR THE FORCES EXERTED ON THEM BY THE UNIT IN ADDITION TO ALL OTHER LOADS AND FORCES.
 - d. VERIFY THAT THE INSTALLATION IS IN CONFORMANCE WITH THE 2013 CBC AND WITH THE DETAILS SHOWN IN THIS PRE-APPROVAL. VERIFY THAT THE EQUIPMENT'S ACTUAL WEIGHT, CG LOCATION, ANCHOR LOCATIONS, ANCHOR DETAILS AND THE MATERIAL AND GAGE OF THE UNIT WHERE ATTACHMENTS ARE MADE AGREE WITH THE FORMATION SHOWN IN THIS PRE-APPROVAL.

5. THE MANUFACTURER SUPPLIED BASE BRACKETS HAVE BEEN EVALUATED FOR THE WORST CASE LOADING PER THE 2013 CBC. STRUCTURAL ENGINEER-OF-RECORD (S.E.O.R.) SHALL EVALUATE BRACKET ANCHORAGE FOR CONDITIONS THAT VARY FROM THIS PRE-APPROVAL.
 CONTRACTOR/INSPECTOR OF RECORD MUST VERIFY ANCHOR SPACING TO ADJACENT EQUIPMENT IS TO BE GREATER THAN 6".
 THIS OPM COVERS ONLY THE SUPPORTS AND ATTACHMENTS OF THE UNIT TO THE STRUCTURE.
 EXPANSION OR WEDGE ANCHORS INTO CONCRETE: HILTI KB-TZ (ICC ESR-1917). INSTALL ANCHORS IN ACCORDANCE WITH THE ICC REPORT AND MANUFACTURER'S RECOMMENDATIONS. TEST AT LEAST 50% OF ANCHORS NO SOONER THAN 24 HOURS AFTER INSTALLATIONS. TESTS SHALL BE CONDUCTED IN THE PRESENCE OF THE INSPECTOR OF RECORD (IOR) AND A REPORT OF THE TEST SHALL BE SUBMITTED TO OSHPD.
6. TEST PER ONE OF THE FOLLOWING METHODS:
 - a. DIRECT PULL TENSION TEST. ANCHOR IS ACCEPTABLE IF NO MOVEMENT IS OBSERVED AT THE TEST LOAD GIVEN IN TABLE BELOW. MOVEMENT MAY BE DETERMINED WHEN THE WASHER UNDER THE NUT BECOMES LOOSE.
 - b. TORQUE WRENCH TEST. TEST ANCHORS TO THE REQUIRED TORQUE LOAD GIVEN IN TABLE BELOW WITHIN THE LIMIT OF ONE-HALF TURN OF THE NUT.
7. TORQUE WRENCH TEST. TEST ANCHORS TO THE REQUIRED TORQUE LOAD GIVEN IN TABLE BELOW WITHIN THE LIMIT OF ONE-HALF TURN OF THE NUT.
8. EXPANSION OR WEDGE ANCHORS INTO CONCRETE: HILTI KB-TZ (ICC ESR-1917). INSTALL ANCHORS IN ACCORDANCE WITH THE ICC REPORT AND MANUFACTURER'S RECOMMENDATIONS. TEST AT LEAST 50% OF ANCHORS NO SOONER THAN 24 HOURS AFTER INSTALLATIONS. TESTS SHALL BE CONDUCTED IN THE PRESENCE OF THE INSPECTOR OF RECORD (IOR) AND A REPORT OF THE TEST SHALL BE SUBMITTED TO OSHPD.
9. IF ANY ANCHOR FAILS DURING TESTING, UNIT MUST BE MOVED SO THAT NO ANCHOR IS WITHIN 12" OF AN ABANDONED ANCHOR.
10. A MANUFACTURER PROVIDED PERMANENT PLAQUE MUST BE AFFIXED ON THE UNIT STATING THE FOLLOWING: WEIGHT OF CONTENTS SHALL NOT EXCEED 10 PCF. DESIGNED WEIGHT OF CONTENTS IS 10 PCF. VERIFY IN FIELD BEFORE INSTALLATION.

ANCHOR TEST LOAD VALUES							
ANCHOR TYPE	ANCHOR DIAMETER	EMBED DEPTH	TENSION LOAD (LBS)	TORQUE LOAD (FT-LBS)	MINIMUM EDGE DIST REQ.	MINIMUM SPACING REQ.	CONCRETE TYPE
HILTI KB-TZ	5/8"	3-1/8"	3,125	60	12"	4-1/2"	NORMAL WEIGHT
HILTI KB-TZ	3/8"	2"	*	25	12"	4-1/2"	SAND LIGHT WEIGHT

*TEST # EXPANSION ANCHOR USING THE TORQUE WRENCH TEST METHOD PER MANUFACTURER'S RECOMMENDATION.

OSHDP PRE-APPROVAL OF MANUFACTURER CERTIFICATION
OPM 0185-13

OMNI-SUPPLIER ONE-, TWO-, AND THREE-CELL CABINETS

OMNICELL

OS104, OSC7104, MDA-FRM-001, MDA-FRM-001-CI, MSA-FRM-001-INT, NAC-FRM-004, NAC-FRM-005, NAC-FRM-009, NAC-FRM-010, OPF-FRM-001, SDA-FRM-001, CSM-FRM-001, CSM-FRM-004-INT, CSM-FRM-007, OPTX1, OX104, OX104-INT, OX104RX, OX104SV



Degenkolb

DEGENKOLB ENGINEERS
225 Montgomery Street, Suite 500
San Francisco, CA 94104
415.981.5152 Phone
415.981.5157 Fax
www.degenkolb.com

REGISTERED PROFESSIONAL ENGINEER
STATE OF CALIFORNIA
No. 55716

OMNI-SUPPLIER ONE-CELL CABINET MODELS
OS104, OSC7104, MDA-FRM-001, MDA-FRM-001-CI, MSA-FRM-001-INT, NAC-FRM-004, NAC-FRM-005, NAC-FRM-009, NAC-FRM-010, OPF-FRM-001, SDA-FRM-001, CSM-FRM-001, CSM-FRM-004-INT, CSM-FRM-007, OPTX1, OX104, OX104-INT, OX104RX, OX104SV

OMNI-SUPPLIER TWO-CELL CABINET MODELS
OS224, OSC7224, MDA-FRM-002, MDA-FRM-002-CI, MSA-FRM-002-INT, NAC-FRM-005, NAC-FRM-006, NAC-FRM-007, NAC-FRM-008, OPF-FRM-002, SDA-FRM-002, CSM-FRM-002, CSM-FRM-005-INT, CSM-FRM-008, OPTX2, OX224, OX224-INT, OX224RX, OX224SV

OMNI-SUPPLIER THREE-CELL CABINET MODELS
OS344, OSC7344, MDA-FRM-003, MDA-FRM-003-CI, MSA-FRM-003-INT, OPF-FRM-003, SDA-FRM-003, CSM-FRM-003, CSM-FRM-006-INT, CSM-FRM-009, OPTX3, OX344, OX344-INT, OX344RX, OX344SV

CASE 1 - ONE AND TWO CELL CABINETS ABOVE GRADE
SEE TITLE BLOCK FOR MODEL NUMBERS

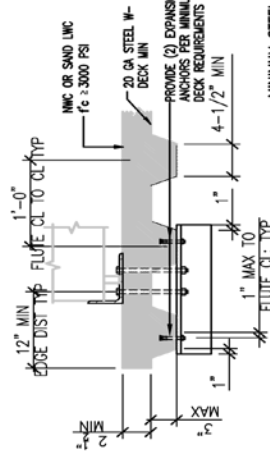
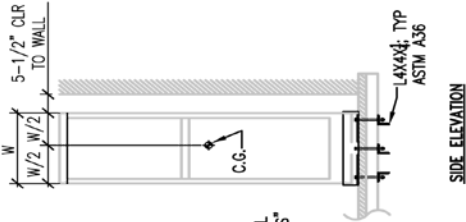
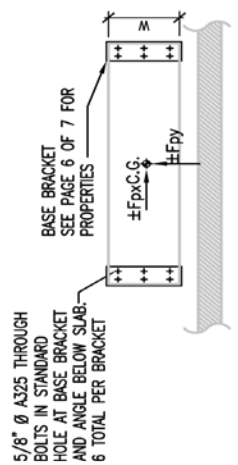
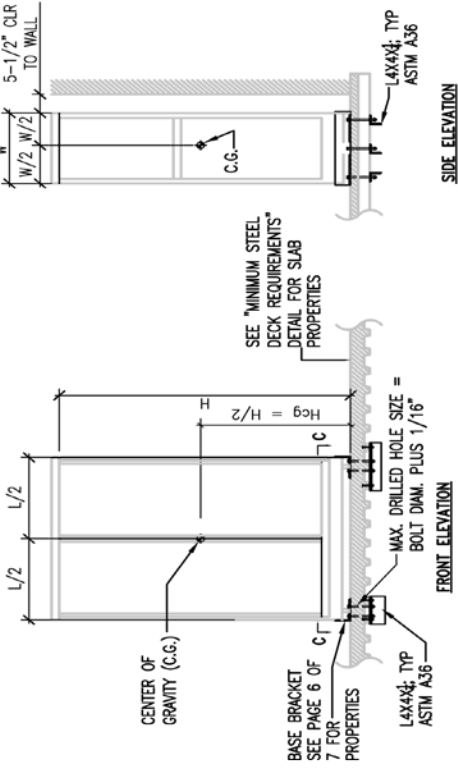

TYPE (SEE TITLE BLOCK FOR MODEL NUMBERS)	Wp (LBS)	FORCES			CABINET PROPERTIES			
		Ruit (LBS)	Vuit (LBS/BOLT)	Flu Vuit (LBS/BOLT)	Tuit (LBS/BOLT)	L (in)	W (in)	H (in)
ONE-CELL CABINETS	1,288	1,714	238	357	1,567	26 1/2	22 1/2	77 1/4
TWO-CELL CABINETS	2,439	2,598	451	677	2,323	51 1/2	22 1/2	77 1/4

$F_p=2.22 W_p$, $S_{ps} = 1.85$, $l_p=1.5$, $R_p=1.0$, $o_p=1.0$, $z/h <=1.0$
 $F_v=0.37 W_p$
 Ruit = MAXIMUM BRACKET PIN UPLIFT FORCE AT STRENGTH LEVEL
 Vuit = MAXIMUM SHEAR PER THROUGH BOLT AT STRENGTH LEVEL = $(F_p/12)$ ANCHORS
 Tuit = MAXIMUM THROUGH BOLT TENSION FORCE AT STRENGTH LEVEL
 Wp = TOTAL WEIGHT; INCLUDES 10 pct CONTENTS PER NOTE 8 ON PAGE 1 OF 7

- NOTES:**
- THE DESIGN OF SUPPORTS AND ATTACHMENTS CONFORMS TO THE 2013 CALIFORNIA BUILDING CODE
 - Ruit, Vuit and Tuit GIVEN ARE FACTOR LOADS AT STRENGTH LEVEL. FINAL DEMAND FORCES FOR BEARING ON CONCRETE AND BREAK OUT OF CONCRETE SHOULD INCLUDE OVERSTRENGTH FACTOR ϕ AS DEFINED BY ASCE 7-10.
 - FOR THE SUPPORT AND ATTACHMENT DESIGN, THE MOST CRITICAL LOAD COMBINATION IS $(0.9 - 0.2S_{ps})DL$
 - SEE GENERAL NOTES SECTION ON PAGE 1.
 - SEE PAGE 6 OF 7 FOR LOCATION OF APPLIED FORCES IN BASE BRACKET.
 - SEE PAGE 6 FOR MANUFACTURER BRACKET INFORMATION.
 - SEE PAGE 6 FOR MANUFACTURER BRACKET INFORMATION. S.E.O.R. MAY RECALCULATE MAX. ANCHOR FORCES Ruit, Vuit AND Tuit, AT THEIR DISCRETION, BASED ON PROJECT SPECIFIC SEISMIC DEMANDS SUBJECT TO OSHPD REVIEW/PERMIT.
 - TOTAL WEIGHT (Wp) IS A MAXIMUM. THIS PRE-APPROVAL ENCOMPASSES ALL WEIGHTS UP TO THE MAXIMUM SHOWN.
 - EQUIPMENT MANUFACTURER MUST DESIGN UNIT TO MAKE Hcg EQUAL OR LESS THAN THE HEIGHT DIMENSION SHOWN.

MINIMUM STEEL DECK REQUIREMENTS

OSHDP PRE-APPROVAL OF MANUFACTURER CERTIFICATION
OPM 0185-13

OMNI-SUPPLIER ONE-, TWO-, AND THREE-CELL CABINETS

OMNICELL

OS104, OSCT104, MDA-FRM-001, MDA-FRM-001-INT, MSA-FRM-001-INT, NAC-FRM-004, NAC-FRM-005, NAC-FRM-009, NAC-FRM-010, OPE-FRM-001, SDA-FRM-001, CSM-FRM-001, CSM-FRM-004-INT, CSM-FRM-007, OPTX1, OX104, OX104-INT, OX104EX, OX104SV

OS224, OSCT224, MDA-FRM-002, MDA-FRM-002-INT, MSA-FRM-002-INT, NAC-FRM-005, NAC-FRM-006, NAC-FRM-007, NAC-FRM-008, OPE-FRM-002, SDA-FRM-002, CSM-FRM-002, CSM-FRM-005-INT, CSM-FRM-008, OPTX2, OX224, OX224-INT, OX224RX, OX224SV

OS344, OSCT344, MDA-FRM-003, MDA-FRM-003-INT, MSA-FRM-003-INT, NAC-FRM-003, NAC-FRM-003, CSM-FRM-006-INT, CSM-FRM-009, OPTX3, OX344, OX344-INT, OX344RX, OX344SV

Degenkolb ENGINEERS

235 Montgomery Street, Suite 500
San Francisco, CA 94104
Tel: 415.381.3157 Fax: 415.381.3157
www.degenkolb.com

REGISTERED PROFESSIONAL ENGINEER
No. 4557
State of California
Structural

CASE 2 – THREE CELL CABINETS ABOVE GRADE
SEE TITLE BLOCK FOR MODEL NUMBERS

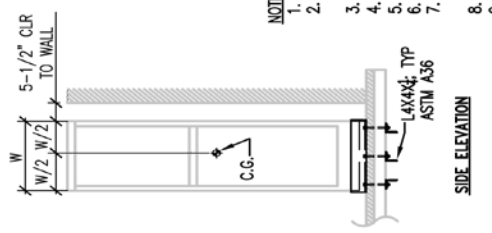
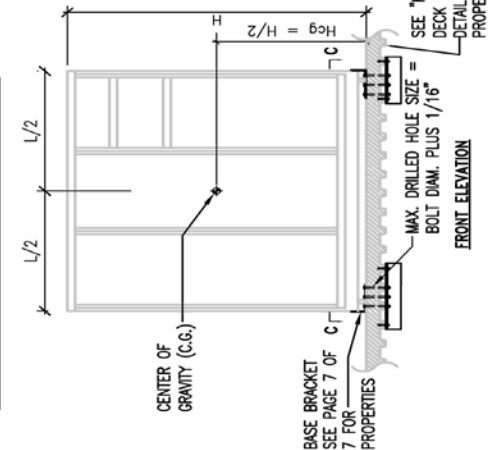

TYPE (SEE TITLE BLOCK FOR MODEL NUMBERS)	Wp (LBS)	RuIt (LBS)	VuIt (LBS/BOLT)	Do VuIt (LBS/BOLT)	TuIt (LBS/BOLT)	CABINET PROPERTIES L W H (in) (in) (in)
THREE CELL CABINETS	3,587	2,442	442	663	2,185	76 1/4 22 1/2 77 1/4

$F_p = 2.22 W_p$, $S_{36} \leq 1.85$, $p = 1.5$, $R_p = 1.5$, $o_p = 1.0$, $D_p = 1.5$, $z/h \leq 1.0$
 $F_v = 0.37 W_p$
 RuIt = MAXIMUM BRACKET PIN UPLIFT FORCE AT STRENGTH LEVEL
 VuIt = MAXIMUM SHEAR PER THROUGH BOLT AT STRENGTH LEVEL
 TuIt = MAXIMUM THROUGH BOLT TENSION FORCE AT STRENGTH LEVEL
 Wp = TOTAL WEIGHT; INCLUDES 10 pct CONTENTS PER NOTE 8 ON PAGE 1 OF 7

- NOTES:**
- THE DESIGN OF SUPPORTS AND ATTACHMENTS CONFORMS TO THE 2013 CALIFORNIA BUILDING CODE.
 - RuIt, VuIt AND TuIt GIVEN ARE FACTOR LOADS AT STRENGTH LEVEL. FINAL DEMAND FORCES FOR BEARING ON CONCRETE AND BREAK OUT OF CONCRETE SHOULD INCLUDE OVERSTRENGTH FACTOR D_o AS DEFINED BY ASCE 7-10.
 - SEE GENERAL NOTES SECTION ON PAGE 1.
 - FOR THE SUPPORT AND ATTACHMENT DESIGN, THE MOST CRITICAL LOAD COMBINATION IS $(0.9 - 0.2S_{36})DL$
 - SEE PAGE 7 OF 7 FOR LOCATION OF APPLIED FORCES IN BASE BRACKET.
 - SEE PAGE 7 FOR MANUFACTURER BRACKET INFORMATION.
 - S.E.O.R. MAY RECALCULATE MAX. ANCHOR FORCES RuIt, VuIt AND TuIt, AT THEIR DISCRETION, BASED ON PROJECT SPECIFIC SEISMIC DEMANDS SUBJECT TO OSHDP REVIEW/PERMIT.
 - TOTAL WEIGHT (Wp) IS A MAXIMUM. THIS PRE-APPROVAL ENCOMPASSES ALL WEIGHTS UP TO THE MAXIMUM SHOWN.
 - EQUIPMENT MANUFACTURER MUST DESIGN UNIT TO MAKE Hog EQUAL OR LESS THAN THE HEIGHT DIMENSION SHOWN.

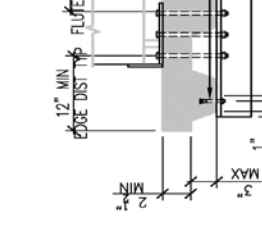
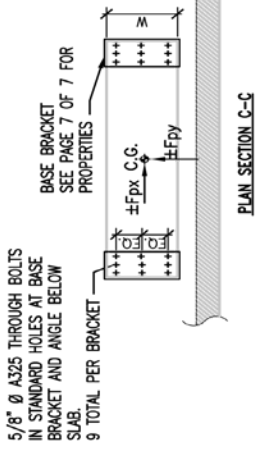

MINIMUM STEEL DECK REQUIREMENTS

<p>OMNICELL OSHPD PRE-APPROVAL OF MANUFACTURER CERTIFICATION OPM 0185-13 OMNI-SUPPLIER ONE-, TWO-, AND THREE-CELL CABINETS</p>	<p>DEGENKOLTB ENGINEERS 228 Montgomery Street, Suite 200 San Francisco, CA 94104 415.392.6622 415.392.1315 Fax www.degenkoltb.com</p>	
<p>OMNI-SUPPLIER ONE-CELL CABINET MODELS OS104, OSCT104, MDA-FRM-001, MDA-FRM-001-CI, USA-FRM-001-INT, MAC-FRM-004, MAC-FRM-005, MAC-FRM-009, MAC-FRM-010, OPE-FRM-001, SDA-FRM-001, CSM-FRM-001, CSM-FRM-001-INT, CSM-FRM-007, OPT01, OX104, OX104-INT, OX104BK, OX104SV</p>	<p>OMNI-SUPPLIER TWO-CELL CABINET MODELS OS224, OSCT224, MDA-FRM-002, MDA-FRM-002-CI, USA-FRM-002-INT, MAC-FRM-003, MAC-FRM-006, MAC-FRM-007, MAC-FRM-008, OPE-FRM-002, SDA-FRM-002, CSM-FRM-002, CSM-FRM-005-INT, CSM-FRM-008, OPT02, OX204, OX204-INT, OX204BK, OX204SV</p>	<p>OMNI-SUPPLIER THREE-CELL CABINET MODELS OS344, OSCT344, MDA-FRM-003, MDA-FRM-003-CI, USA-FRM-003-INT, MAC-FRM-003, SDA-FRM-003, CSM-FRM-003, CSM-FRM-006-INT, CSM-FRM-009, OPT03, OX344, OX344-INT, OX344BK, OX344SV</p>

CASE 3 – ONE AND TWO CELL CABINETS ON GRADE
SEE TITLE BLOCK FOR MODEL NUMBERS

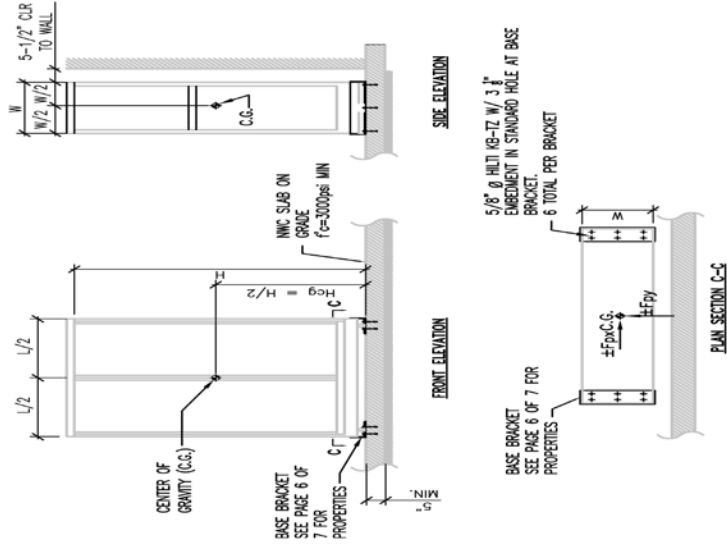



TYPE (SEE TITLE BLOCK FOR MODEL NUMBERS)	FORCES						CABINET PROPERTIES		
	Wp (LBS)	RuIt (LBS)	VuIt (LBS/BOLT)	TuIt (LBS/BOLT)	DoIuR (LBS/BOLT)	TuR (LBS/BOLT)	L (in)	W (in)	H (in)
ONE-CELL CABINETS	1,288	589	89	134	827	865	26 1/2	22 1/2	17 1/4
TWO-CELL CABINETS	2,439	873	168	252	943	1313	51 1/2	22 1/2	17 1/4

$F_p=0.83 W_p$ ($S_g \leq 1.85$, $I_p=1.5$, $R_p=1.5$, $q_p=1.0$, $D_p=1.5$, $z/h=0$)
 $F_r=0.37 W_p$
 RuIt = MAXIMUM BRACKET PIN UPLIFT FORCE AT STRENGTH LEVEL
 VuIt = MAXIMUM SHEAR PER EXPANSION ANCHOR AT STRENGTH LEVEL = $(F_p/2)$ ANCHORS
 TuIt = MAXIMUM EXPANSION ANCHOR TENSION FORCE AT STRENGTH LEVEL
 Wp = TOTAL WEIGHT; INCLUDES 10 per CONTENTS PER NOTE 8 ON PAGE 1 OF 7

NOTES:

1. THE DESIGN OF SUPPORTS AND ATTACHMENTS CONFORMS TO THE 2013 CALIFORNIA BUILDING CODE.
2. RuI, VuI and TuI GIVEN ARE FACTOR LOADS AT STRENGTH LEVEL. FINAL DEMAND FORCES FOR ANCHORAGE TO CONCRETE SHOULD INCLUDE OVERSTRENGTH FACTOR (O_s) AS DEFINED BY ASCE 7-10.
3. FOR THE SUPPORT AND ATTACHMENT DESIGN, THE MOST CRITICAL LOAD COMBINATION IS $(0.9 + 0.25S_u)D$.
4. SEE GENERAL NOTES SECTION ON PAGE 1.
5. SEE PAGE 6 OF 7 FOR LOCATION OF APPLIED FORCES IN BASE BRACKET.
6. SEE PAGE 6 FOR MANUFACTURER BRACKET INFORMATION.
7. S.E.O.R. MAY RECALCULATE MAX. ANCHOR FORCES RuI, VuI, AND TuI, AT THEIR DISCRETION, BASED ON PROJECT SPECIFIC SEISMIC DEMANDS SUBJECT TO OSHPD REVIEW/PERMIT.
8. TOTAL WEIGHT (Wp) IS A MAXIMUM. THIS PRE-APPROVAL ENCOMPASSES ALL WEIGHTS UP TO THE MAXIMUM SHOWN.
9. EQUIPMENT MANUFACTURER MUST DESIGN UNIT TO MAKE Hcg EQUAL OR LESS THAN THE HEIGHT DIMENSION SHOWN.

OSHDP PRE-APPROVAL OF MANUFACTURER CERTIFICATION OPM 0185-13		OMNICELL OSHDP PRE-APPROVAL OF MANUFACTURER CERTIFICATION OPM 0185-13		 Degenkolb DEGENKOLB ENGINEERS 228 Montgomery Street, Suite 500 San Francisco, CA 94104 Tel: 415.392.8822 Fax: 415.392.3157 www.degenkolb.com			
OMNI-SUPPLIER ONE-CELL CABINET MODELS OS104, OSC1104, MDA-FRM-001, MDA-FRM-001-CI, MSA-FRM-001-INT, NAC-FRM-001, NAC-FRM-005, NAC-FRM-009, NAC-FRM-010, OPF-FRM-001, SDA-FRM-001, CSM-FRM-004-INT, CSM-FRM-005-INT, CSM-FRM-007, OPTIX1, OX104, OX104-INT, OX104RX, OX104SV		OMNI-SUPPLIER TWO-CELL CABINET MODELS OS224, OSC224, MDA-FRM-002, MDA-FRM-002-CI, MSA-FRM-002-INT, NAC-FRM-002, NAC-FRM-006, NAC-FRM-007, NAC-FRM-008, OPF-FRM-002, SDA-FRM-002, CSM-FRM-002, CSM-FRM-005-INT, CSM-FRM-008, OPTIX2, OX224, OX224-INT, OX224RX, OX224SV		OMNI-SUPPLIER THREE-CELL CABINET MODELS OS344, OSC344, MDA-FRM-003, MDA-FRM-003-CI, MSA-FRM-003-INT, OPF-FRM-003, SDA-FRM-003, CSM-FRM-003, CSM-FRM-006-INT, CSM-FRM-009, OPTIX3, OX344, OX344-INT, OX344RX, OX344SV		REAR SIDE OF UNIT OMNI-SUPPLIER CABINET ASTM A1008 CS TYPE B $f_y = 33$ KSI MIN; VERIFY MATERIAL PROPERTIES PER ASTM 370 DOWEL PIN INTO ASTM A1008 12GA CASING ($f_y = 33$ KSI MIN) AT BACK OF CABINET EXPANSION ANCHOR OR THROUGH BOLT PER SHEET 2 OR 4 RESPECTIVELY.	

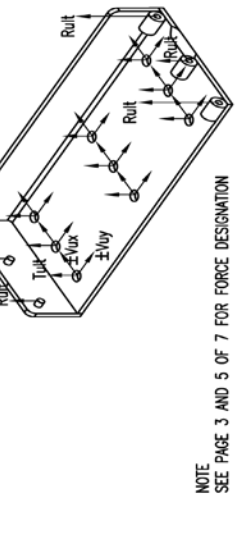
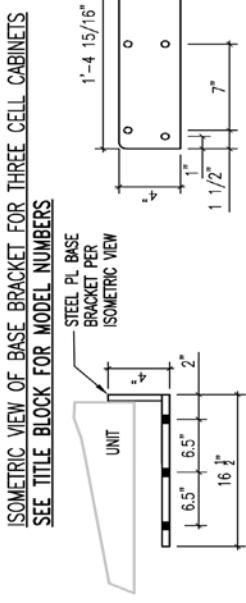
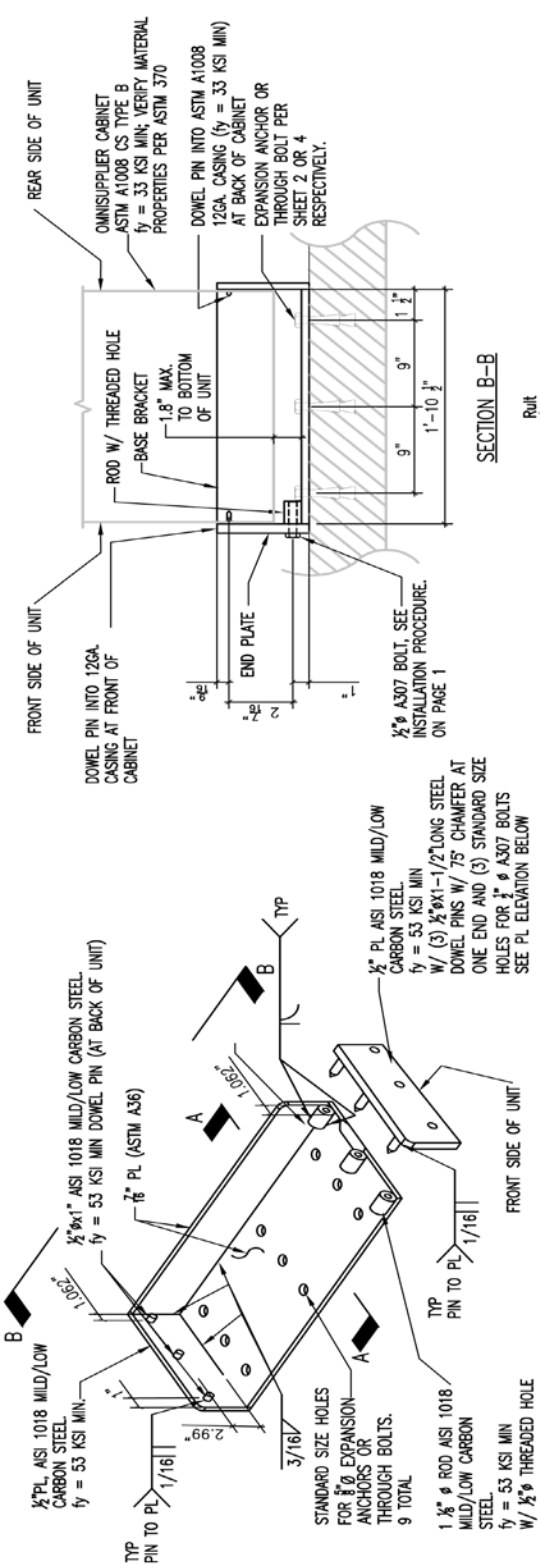

1/2" PL ON THE FRONT SIDE OF THE UNIT

FORCE DISTRIBUTION IN BASE BRACKET



OSHPD PRE-APPROVAL OF MANUFACTURER CERTIFICATION
OPM - 0186 - 13

OMNICELL OMNIRX CABINETS
MODELS MDA-FRM-005, MDA-FRM-005-CI, MDA-FRM-007-INT, NAC-FRM-003, RXAX, RXAX-INT, RXBLU, RXCT AND RXCT-INT

DEGENKOLB ENGINEERS
225 Montgomery Street, Suite 900
San Francisco, CA 94104
415.392.6692 Phone
415.981.3157 Fax
www.degenkolb.com



- GENERAL NOTES:**
1. THIS OSHPD PRE-APPROVAL OF MANUFACTURER'S CERTIFICATION (OPM) IS BASED ON THE CBC 2013. THE DEMAND (DESIGN FORCES) FOR USE WITH THIS OPM SHALL BE BASED ON THE CBC 2013.
 2. PRE-APPROVED BUILDING AND MATERIALS CONFORM WITH THE 2013 EDITION OF THE CALIFORNIA BUILDING CODE. DETAILS WITHIN THIS APPROVAL MAY BE USED ANYWHERE IN THE STATE OF CALIFORNIA WHERE $S_g \leq 2.5$.
 3. SEISMIC FORCES ON EQUIPMENT DETERMINED PER THE 2013 CBC & ASCE 7-10 SECTION 13.3. ALL LOADS IN THIS PRE-APPROVAL ARE AT STRENGTH LEVEL AND SHALL BE USED FOR STRENGTH DESIGN.
 - a. CASE 1 (EQUIPMENT ABOVE GRADE TO ROOF): $S_g \leq 2.5$, $op=1.0$, $R_p=1.5$, $lp=1.5$, $0p=1.5$, $z/h \leq 1.0$
 - i. $F_p=3.00W_p$, $F_v=0.50W_p$
 - b. CASE 2 (EQUIPMENT AT OR BELOW GRADE): $S_g \leq 2.5$, $op=1.0$, $R_p=1.5$, $lp=1.5$, $z/h = 0.0$, $0p=1.5$
 - i. $F_p=1.13W_p$, $F_v=0.50W_p$
 4. THE STRUCTURAL ENGINEER-OF-RECORD (S.E.O.R.) IS RESPONSIBLE FOR THE FOLLOWING:
 - a. VERIFY THAT THE ANCHORS ARE AN ADEQUATE DISTANCE FROM ANY SLAB OPENINGS OR EDGES.
 - b. VERIFY THAT THE ANCHORS ARE AN ADEQUATE DISTANCE FROM ANY NEW OR EXISTING ANCHORS.
 - c. DESIGN ANY SUPPLEMENTARY MEMBERS AND THEIR ATTACHMENTS WHICH THE UNIT IS ANCHORED TO. VERIFY THE ADEQUACY OF ANY EXISTING MEMBERS AND THEIR ATTACHMENTS WHICH THE UNIT IS ANCHORED TO FOR THE FORCES EXERTED ON THEM BY THE UNIT IN ADDITION TO ALL OTHER LOADS AND FORCES.
 - d. VERIFY THAT THE INSTALLATION IS IN CONFORMANCE WITH THE 2013 CBC AND WITH THE DETAILS SHOWN IN THIS PRE-APPROVAL. VERIFY THAT THE EQUIPMENT'S ACTUAL WEIGHT, CG LOCATION, ANCHOR LOCATIONS, ANCHOR DETAILS AND THE MATERIAL AND GAGE OF THE UNIT WHERE ATTACHMENTS ARE MADE AGREE WITH THE FORMATION SHOWN IN THIS PRE-APPROVAL.
 5. STRUCTURAL ENGINEER-OF-RECORD (S.E.O.R.) SHALL EVALUATE BRACKET ANCHORAGE FOR CONDITIONS THAT VARY FROM THIS PRE-APPROVAL.
 6. CONTRACTOR/INSPECTOR OF RECORD MUST VERIFY ANCHOR SPACING TO ADJACENT EQUIPMENT IS TO BE GREATER THAN 12".
 7. THIS OPM COVERS ONLY THE SUPPORTS AND ATTACHMENTS OF THE UNIT TO THE STRUCTURE
 8. EXPANSION OR WEDGE ANCHORS INTO CONCRETE: HILTI KB-TZ (ICC ESR-1917). INSTALL ANCHORS IN ACCORDANCE WITH THE ICC REPORT AND MANUFACTURER'S RECOMMENDATIONS. TEST AT LEAST 50% OF ANCHORS NO SOONER THAN 24 HOURS AFTER INSTALLATIONS. TESTS SHALL BE CONDUCTED IN THE PRESENCE OF THE INSPECTOR OF RECORD (IOR) AND A REPORT OF THE TEST SHALL BE SUBMITTED TO OSHPD.
- TEST PER ONE OF THE FOLLOWING METHODS:
- a. DIRECT PULL TENSION TEST. ANCHOR IS ACCEPTABLE IF NO MOVEMENT IS OBSERVED AT THE TEST LOAD GIVEN IN TABLE BELOW. MOVEMENT MAY BE DETERMINED WHEN THE WASHER UNDER THE NUT BECOMES LOOSE.
 - b. TORQUE WRENCH TEST: TEST ANCHORS TO THE REQUIRED TORQUE LOAD GIVEN IN TABLE BELOW WITHIN THE LIMIT OF ONE-HALF TURN OF THE NUT.
- | ANCHOR TEST LOAD VALUES: (NORMAL WEIGHT CONCRETE) | | | | | |
|---|-----------------|----------------|--------------------|----------------------|---------------------------------------|
| ANCHOR TYPE | ANCHOR DIAMETER | EMBED h_{ef} | TENSION LOAD (LBS) | TORQUE LOAD (FT-LBS) | f_c MIN SPACING AND EDGE DIST. REQ. |
| HILTI KB-TZ | 5/8" | 3-1/8" | 3,125 | 60 | 3,000 |
| | | | | | 5,800" |
9. IF ANY ANCHOR FAILS DURING TESTING, UNIT MUST BE MOVED SO THAT NO ANCHOR IS WITHIN 12" OF AN ABANDONED ANCHOR.
 10. A MANUFACTURER PROVIDED PERMANENT PLAQUE MUST BE AFFIXED ON THE UNIT STATING THE FOLLOWING: "WEIGHT OF CONTENTS SHALL NOT EXCEED 10 PCF". DESIGNED WEIGHT OF CONTENTS IS 20 PCF. VERIFY IN FIELD BEFORE INSTALLATION.
11. FOR BOLTS THROUGH CONCRETE ON METAL DECK
 - A. BOLTS SHALL BE TORQUED BY 3/4 TURN OF THE NUTS AFTER THE SNUG TIGHT CONDITION (SNUG TIGHT CONDITION IS DEFINED AS THE TIGHTNESS REQUIRED TO BRING THE CONNECTED PILES INTO FIRM CONTACT) IS ACHIEVED.
 - B. THROUGH BOLTS IN CONCRETE SHALL RECEIVE SPECIAL INSPECTION AND TESTING IN ACCORDANCE WITH REQUIREMENTS FOR POST-INSTALLED ANCHORS.
 12. INSTALLATION PROCEDURE:
 - a. MOUNT BASE BRACKET PROVIDED BY OMNICELL TO FLOOR WITH THROUGH BOLTS OR EXPANSION ANCHORS RESPECTIVELY.
 - b. ROLL UNIT ONTO BASE BRACKET WITH DOWEL PIN INSERTING INTO BACK CASING OF UNIT.
 - c. PIN UNIT AT FRONT WITH END PLATE, CONNECTING IT TO BOTH THE UNIT CASING AND THE CASE BRACKET.



OSHPD PRE-APPROVAL OF MANUFACTURER CERTIFICATION
OPM - 0186 - 13

OMNICELL OMNIRX CABINETS
MODELS MDA-FRM-005, MDA-FRM-005-CI, MDA-FRM-007-INT, NAC-FRM-003, RXAX, RXAX-INT, RXBLU, RXCT AND RXCT-INT

DEGENKOLB ENGINEERS
235 Montgomery Street, Suite 500
San Francisco, CA 94104
415.392.6652 Phone
415.981.3157 Fax
www.degenkolb.com



CASE 1 - EQUIPMENT ABOVE GRADE

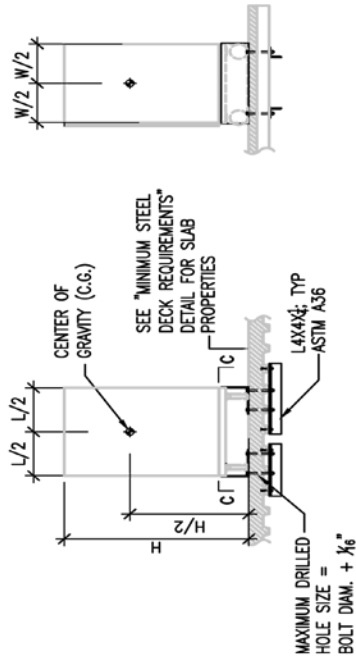

**FRONT ELEVATION
OMNIRX**

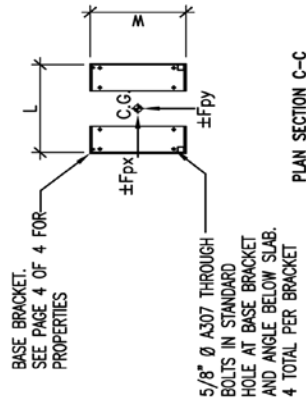

PLAN SECTION C-C

MODEL	Wp (LBS)	FORCES			CABINET PROPERTIES		
		Ruit* (LBS)	Vuit* (LBS/BOLT)	Tuit* (LBS/BOLT)	L (in)	W (in)	H (in)
ALL MODELS (SEE TITLE BLOCK)	850	1,525	360	1,255	25 7/8	22 5/8	45 9/32

* Does not include overstrength factor (Do)
 $Fp=3.00 Wp$ [$S_{ps} \leq 2.5$, $Ip=1.5$, $Rp=1.5$, $op=1.0$, $Qs=1.5$, $z/h \leq 1.0$]
 $Fv=0.50 Wp$

Ruit = MAXIMUM BRACKET PIN UPLIFT FORCE AT STRENGTH LEVEL
 Vuit = MAXIMUM SHEAR PER THROUGH BOLT AT STRENGTH LEVEL
 Tuit = MAXIMUM THROUGH BOLT TENSION FORCE AT STRENGTH LEVEL
 Wp = TOTAL WEIGHT; INCLUDES 20 PER CONTENTS PER NOTE 10 ON PAGE 1 OF 4

NOTES:

1. THE DESIGN OF SUPPORTS AND ATTACHMENTS CONFORMS TO THE 2013 CALIFORNIA BUILDING CODE.
2. Ruit, Vuit and Tuit GIVEN ARE FACTOR LOADS AT STRENGTH LEVEL. FINAL DEMAND FORCES FOR ANCHORAGE TO CONCRETE SHALL INCLUDE OVERSTRENGTH FACTOR Do AS DEFINED BY ASCE 7-10.
3. FOR THE SUPPORT AND ATTACHMENT DESIGN, THE MOST CRITICAL LOAD COMBINATION IS $(0.9 - 0.2S_{ps})DL$
4. SEE GENERAL NOTES SECTION ON PAGE 1.
5. SEE PAGE 4 OF 4 FOR LOCATION OF APPLIED FORCES IN BASE BRACKET.
6. SEE PAGE 4 OF 4 FOR MANUFACTURER BRACKET INFORMATION.
7. S.E.O.R. MAY RECALCULATE MAX. ANCHOR FORCES Ruit, Vuit AND Tuit, AT THEIR DISCRETION, BASED ON PROJECT SPECIFIC SEISMIC DEMANDS SUBJECT TO OSHPD REVIEW/PERMIT.
8. TOTAL WEIGHT (Wp) IS A MAXIMUM. THIS PREAPPROVAL ENCOMPASSES ALL WEIGHTS UP TO THE MAXIMUM SHOWN.
9. EQUIPMENT MANUFACTURER MUST DESIGN UNIT TO MAKE Hcg EQUAL OR LESS THAN THE HEIGHT DIMENSION SHOWN.
10. FOR SLABS OR CONCRETE FILL GREATER THAN 5" THICK WITH $f_c \geq 3000$ PSI NORMAL WEIGHT CONCRETE, MAY USE $\frac{3}{4}$ " HILTI KB-TZ W/ 3-1/8" EMBED IN LIEU OF THROUGH BOLTS.

SIDE ELEVATION

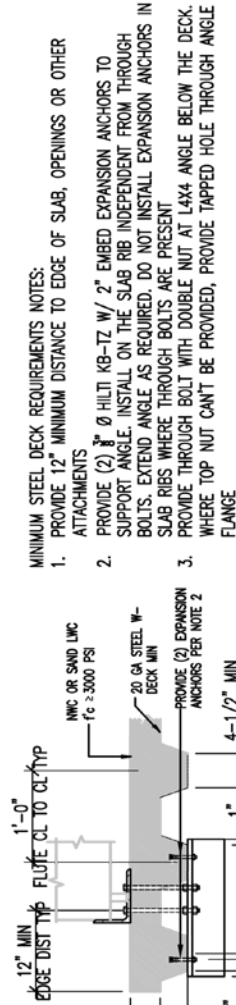

MINIMUM STEEL DECK REQUIREMENTS

MINIMUM STEEL DECK REQUIREMENTS NOTES:

1. PROVIDE 12" MINIMUM DISTANCE TO EDGE OF SLAB, OPENINGS OR OTHER ATTACHMENTS
2. PROVIDE (2) $\frac{3}{4}$ " HILTI KB-TZ W/ 2" EMBED EXPANSION ANCHORS TO SUPPORT ANGLE. INSTALL ON THE SLAB RIB INDEPENDENT FROM THROUGH BOLTS. EXTEND ANGLE AS REQUIRED. DO NOT INSTALL EXPANSION ANCHORS IN SLAB RIBS WHERE THROUGH BOLTS ARE PRESENT
3. PROVIDE THROUGH BOLT WITH DOUBLE NUT AT L4X4 ANGLE BELOW THE DECK. WHERE TOP NUT CAN'T BE PROVIDED, PROVIDE TAPPED HOLE THROUGH ANGLE FLANGE



OSHDP PRE-APPROVAL OF MANUFACTURER CERTIFICATION
OPM - 0186 - 13

DEGENKOLB ENGINEERS
235 Montgomery Street, Suite 500
San Francisco, CA 94104
415.392.8952 Phone
415.981.3157 Fax
www.degenkolb.com



OMNICELL OMNIRX CABINETS
MODELS MDA-FRM-005, MDA-FRM-005-CI, MDA-FRM-007-INT, NAC-FRM-003, RXAX, RXAX-INT, RXBLU, RXCT AND RXCT-INT

CASE 2 - EQUIPMENT AT OR BELOW GRADE

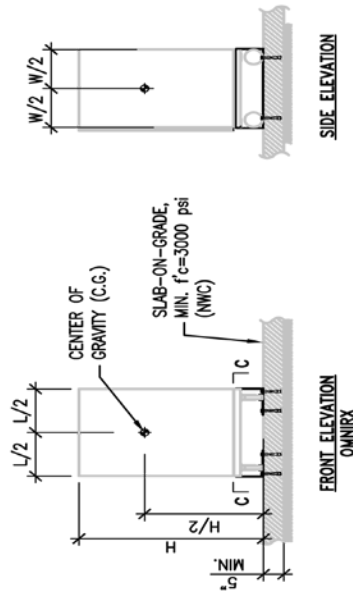

MODEL	Wp (LBS)	FORCES				CABINET PROPERTIES			
		RuIt* (LBS)	VuIt* (LBS/BOLT)	ΩoVuIt (LBS/BOLT)	TuIt* (LBS/BOLT)	ΩoTuIt (LBS/BOLT)	L (in)	W (in)	H (in)
ALL MODELS (SEE TITLE BLOCK)	850	518	125	1188	445	679	25 7/8	22 5/8	45 9/32

* Does not include overstrength factor (Ωo)

$F_p = 1.13 W_p$ [$S_{ps} \leq 2.5$, $I_p = 1.5$, $R_p = 1.5$, $q_p = 1.0$, $\Omega_b = 1.5$, $z/h = 0$]
 $F_v = 0.50 W_p$
 RuIt = MAXIMUM BRACKET PIN UPLIFT FORCE AT STRENGTH LEVEL
 VuIt = MAXIMUM SHEAR PER EXPANSION ANCHOR AT STRENGTH LEVEL
 TuIt = MAXIMUM EXPANSION ANCHOR TENSION FORCE AT STRENGTH LEVEL
 Wp = TOTAL WEIGHT; INCLUDES 20 pcf CONTENTS PER NOTE 10 ON PAGE 1 OF 4

NOTES:

- THE DESIGN OF SUPPORTS AND ATTACHMENTS CONFORMS TO THE 2013 CALIFORNIA BUILDING CODE.
- RuIt, VuIt AND TuIt GIVEN ARE FACTOR LOADS AT STRENGTH LEVEL. FINAL DEMAND FORCES FOR ANCHORAGE TO CONCRETE SHALL INCLUDE OVERSTRENGTH FACTOR Ωo AS DEFINED BY ASCE 7-10.
- FOR THE SUPPORT AND ATTACHMENT DESIGN, THE MOST CRITICAL LOAD COMBINATION IS $(0.9 + 0.2S_{ps}) \times DL$.
- SEE GENERAL NOTES SECTION ON PAGE 1.
- SEE PAGE 4 OF 4 FOR LOCATION OF APPLIED FORCES IN BASE BRACKET.
- SEE PAGE 4 OF 4 FOR MANUFACTURER BRACKET INFORMATION.
- S.E.O.R. MAY RECALCULATE MAX. ANCHOR FORCES RuIt, VuIt AND TuIt, AT THEIR DISCRETION, BASED ON PROJECT SPECIFIC SEISMIC DEMANDS SUBJECT TO OSHDP REVIEW/PERMIT.
- TOTAL WEIGHT (Wp) IS A MAXIMUM. THIS PRE-APPROVAL ENCOMPASSES ALL WEIGHTS UP TO THE MAXIMUM SHOWN.
- EQUIPMENT MANUFACTURER MUST DESIGN UNIT TO MAKE Hog EQUAL OR LESS THAN THE HEIGHT DIMENSION SHOWN.

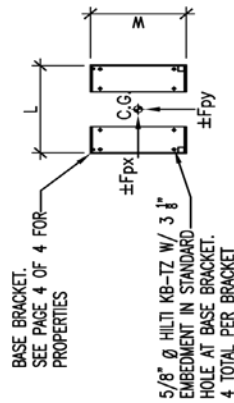

BASE BRACKET.
SEE PAGE 4 OF 4 FOR PROPERTIES

5/8" Ø HILTI KB-TZ W/ 3 1/8" EMBEDMENT IN STANDARD HOLE AT BASE BRACKET.
4 TOTAL PER BRACKET

PLAN SECTION C-C



OSHPD PRE-APPROVAL OF MANUFACTURER CERTIFICATION
OPM-0187 -13

DEGENKOLB ENGINEERS
225 Montgomery Street, Suite 500
San Francisco, CA 94104
415.392.8592 Phone
415.981.3157 Fax
www.degenkolb.com



OMNICELL
YUYAMA MODELS 260, 336 AND 520

- GENERAL NOTES:**
1. THIS OSHPD PRE-APPROVAL OF MANUFACTURER'S CERTIFICATION (OPM) IS BASED ON THE CBC 2013. THE DEMAND (DESIGN FORCES) FOR USE WITH THIS OPM SHALL BE BASED ON THE CBC 2013.
 2. PRE-APPROVED DESIGN AND MATERIALS CONFORM WITH THE 2013 EDITION OF THE CALIFORNIA BUILDING CODE. DETAILS WITHIN THIS APPROVAL MAY BE USED ANYWHERE IN THE STATE OF CALIFORNIA WHERE S₆₈ ≤ 2.5.
 3. SEISMIC FORCES ON EQUIPMENT DETERMINED PER THE 2013 CBC & ASCE 7-10 SECTION 13.3. ALL LOADS IN THIS PRE-APPROVAL ARE AT STRENGTH LEVEL AND SHALL BE USED FOR STRENGTH DESIGN.
 - a. CASE 1 (EQUIPMENT ABOVE GRADE TO ROOF): S₆₈=2.5, op=1.0, R_p=1.5, I_p=1.5, D₀=1.5, z/h ≤ 1.0
 - i. F_p=3.00W_p, F_v=0.50W_p
 - b. CASE 2 (EQUIPMENT AT OR BELOW GRADE): S₆₈=2.5, op=1.0, R_p=1.5, I_p=1.5, z/h = 0.0, D₀=1.5
 - i. F_p=1.13W_p, F_v=0.50W_p
 4. THE STRUCTURAL ENGINEER-OF-RECORD (S.E.O.R.) IS RESPONSIBLE FOR THE FOLLOWING:
 - a. VERIFY THAT THE ANCHORS ARE AN ADEQUATE DISTANCE FROM ANY SLAB OPENINGS OR EDGES.
 - b. VERIFY THAT THE ANCHORS ARE AN ADEQUATE DISTANCE FROM ANY NEW OR EXISTING ANCHORS.
 - c. DESIGN ANY SUPPLEMENTARY MEMBERS AND THEIR ATTACHMENTS WHICH THE UNIT IS ANCHORED TO. VERIFY THE ADEQUACY OF ANY EXISTING MEMBERS AND THEIR ATTACHMENTS WHICH THE UNIT IS ANCHORED TO FOR THE FORCES EXERTED ON THEM BY THE UNIT IN ADDITION TO ALL OTHER LOADS AND FORCES.
 - d. VERIFY THAT THE INSTALLATION IS IN CONFORMANCE WITH THE 2013 CBC AND WITH THE DETAILS SHOWN IN THIS PRE-APPROVAL. VERIFY THAT THE EQUIPMENT'S ACTUAL WEIGHT, CG LOCATION, ANCHOR LOCATIONS, ANCHOR DETAILS AND THE MATERIAL AND GAGE OF THE UNIT WHERE ATTACHMENTS ARE MADE AGREE WITH THE FORMATION SHOWN IN THIS PRE-APPROVAL.
 5. STRUCTURAL ENGINEER-OF-RECORD (S.E.O.R.) SHALL EVALUATE BRACKET ANCHORAGE FOR CONDITIONS THAT VARY FROM THIS PRE-APPROVAL.
 6. CONTRACTOR/INSPECTOR OF RECORD MUST VERIFY ANCHOR SPACING TO ADJACENT EQUIPMENT IS TO BE GREATER THAN 14".
 7. THIS OPM COVERS ONLY THE SUPPORTS AND ATTACHMENTS OF THE UNIT TO THE STRUCTURE.
 8. EXPANSION OR WEDGE ANCHORS INTO CONCRETE: HILTI KB-TZ (ICC ESR-1917). INSTALL ANCHORS IN ACCORDANCE WITH THE ICC REPORT AND MANUFACTURER'S RECOMMENDATIONS. TEST AT LEAST 50% OF ANCHORS NO SOONER THAN 24 HOURS AFTER INSTALLATIONS. TESTS SHALL BE CONDUCTED IN THE PRESENCE OF THE INSPECTOR OF RECORD (OR) AND A REPORT OF THE TEST SHALL BE SUBMITTED TO OSHPD.
- TEST PER ONE OF THE FOLLOWING METHODS:
- a. DIRECT PULL TENSION TEST: ANCHOR IS ACCEPTABLE IF NO MOVEMENT IS OBSERVED AT THE TEST LOAD GIVEN IN TABLE BELOW. MOVEMENT MAY BE DETERMINED WHEN THE WASHER UNDER THE NUT BECOMES LOOSE.
 - b. TORQUE WRENCH TEST: TEST ANCHORS TO THE REQUIRED TORQUE LOAD GIVEN IN TABLE BELOW WITHIN THE LIMIT OF ONE-HALF TURN OF THE NUT.
- | ANCHOR TEST LOAD VALUES | | | | | | | |
|-------------------------|-----------------|-------------|--------------------|----------------------|-------------------|---------------|-------------------------------------|
| ANCHOR TYPE | ANCHOR DIAMETER | EMBED DEPTH | TENSION LOAD (LBS) | TORQUE LOAD (FT-LBS) | CONCRETE TYPE | f'c MIN (PSI) | MINIMUM SPACING AND EDGE DIST. REQ. |
| HILTI KB-TZ | 5/8" | 3-1/8" | 3,125 | 60 | NORMAL WEIGHT | 3,000 | 14" |
| HILTI KB-TZ | 3/8" | 2" | SEE NOTE a | 25 | SAND LIGHT WEIGHT | 3,000 | 14" |
- a. TEST 3/8" EXPANSION ANCHORS USING THE TORQUE WRENCH TEST METHOD AS DESCRIBED ABOVE
 9. IF ANY ANCHOR FAILS DURING TESTING, UNIT MUST BE MOVED SO THAT NO ANCHOR IS WITHIN 14" OF AN ABANDONED ANCHOR.
 10. A MANUFACTURER PROVIDED PERMANENT PLAQUE MUST BE AFFIXED ON THE UNIT STATING THE FOLLOWING: "WEIGHT OF CONTENTS SHALL NOT EXCEED 10 PCF". DESIGNED WEIGHT OF CONTENTS IS 20 PCF. VERIFY IN FIELD BEFORE INSTALLATION.
11. FOR BOLTS THROUGH CONCRETE ON METAL DECK
 - A. BOLTS SHALL BE TORQUED BY 3/4 TURN OF THE NUTS AFTER THE SNUG TIGHT CONDITION (SNUG TIGHT CONDITION IS DEFINED AS THE TIGHTNESS REQUIRED TO BRING THE CONNECTED PILES INTO FIRM CONTACT) IS ACHIEVED.
 - B. THROUGH BOLTS IN CONCRETE SHALL RECEIVE SPECIAL INSPECTION AND TESTING IN ACCORDANCE WITH REQUIREMENTS FOR POST-INSTALLED ANCHORS.
 12. INSTALLATION PROCEDURE:
 - a. MOUNT BASE ANGLE PROVIDED BY OMNICELL TO FLOOR WITH THROUGH BOLTS.
 - b. POSITION UNIT WITH RESPECT TO BASE ANGLES. DOWEL INTO UNIT AS SHOWN.



DEGENKOLB ENGINEERS
225 Montgomery Street, Suite 500
San Francisco, CA 94104
415.582.6692 Phone
415.581.3157 Fax
www.degenkolb.com

OSHPD PRE-APPROVAL OF MANUFACTURER CERTIFICATION
OPM-1187 - 13



OMNICELL
YUYAMA MODELS 260, 336 AND 520

OMNICELL	Wp (LBS)	L ₁ (IN)	L ₂ (IN)	B (IN)	B ₁ (IN)	B ₂ (IN)	H (IN)	Hg (IN)
MODEL 260:	1530	16.7	35.0	36.6	6.1	25.6	78.7	36.7
MODEL 336:	1930	23.5	50.8	36.6	7.9	25.6	78.7	38.0
MODEL 520:	3007	35.0	70.0	36.6	9.0	25.6	78.7	38.6

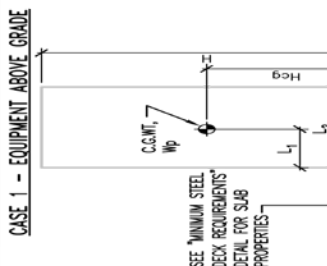
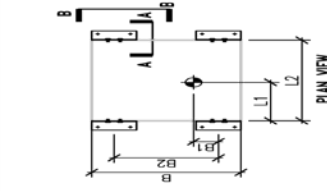

- NOTES:**
- ANCHORAGE DESIGN CONFORMS TO THE 2013 CALIFORNIA BUILDING CODE. FORCES GIVEN ARE FACTORED LOADS THAT SHALL BE USED FOR STRENGTH DESIGN.
 - SEE GENERAL NOTES SECTION PAGE 1.
 - SEE PAGE 4 FOR FORCE DEMANDS APPLIED TO THE SUPPORTS AND ATTACHMENTS.
 - SEC. OR. MAY RECALCULATE MAX. ANCHOR FORCES AT THEIR DISCRETION BASED ON PROJECT SPECIFIC SEISMIC DEMANDS. SUBJECT TO OSHPD REVIEW/PERMIT.
 - PROVIDE HEX NUT AT TOP AND BOTTOM OF STRUT FLANGE, TOP, U.O.M. AT CONDITIONS WHERE NUT CANNOT BE PROVIDED AT TOP SIDE OF STRUT. PROVIDE TAPPED HOLE THROUGH STRUT FLANGE.
 - SEC. OR. SHALL PROVIDE STRUCTURE TO SUPPORT WEIGHTS AND FORCES SHOWN IN COMBINATION WITH ALL OTHER LOADS THAT MAY BE PRESENT.
 - TOTAL WEIGHT (Wp) IS A MAXIMUM. THIS PRE-APPROVAL ENCOMPASSES ALL WEIGHTS UP TO THE MAXIMUM SHOWN.
 - EQUIPMENT MANUFACTURER MUST DESIGN UNIT TO MAKE Hg EQUAL OR LESS THAN THE HEIGHT DIMENSION SHOWN.

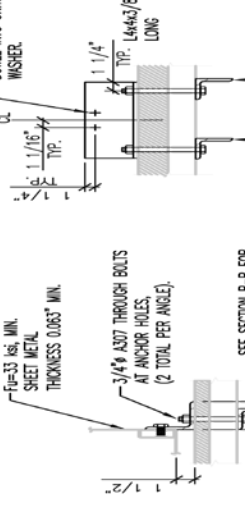
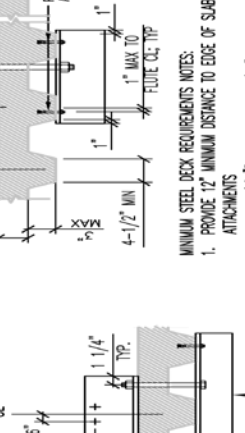
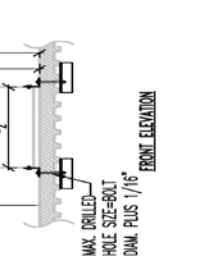
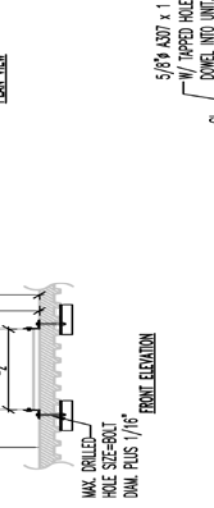

- MINIMUM STEEL DECK REQUIREMENTS NOTES:**
- PROVIDE 12" MINIMUM DISTANCE TO EDGE OF SLAB, OPENINGS OR OTHER ATTACHMENTS
 - PROVIDE (2) 7/8" Ø HILTI IKG-TZ W/ 2" EMBED EXPANSION ANCHORS TO SUPPORT ANGLE. INSTALL ON THE SLAB RIB INDEPENDENT FROM THROUGH BOLTS. EXTEND ANGLE AS REQUIRED. DO NOT INSTALL EXPANSION ANCHORS IN SLAB RISERS WHERE THROUGH BOLTS ARE PRESENT
 - W-STEEL METAL DECK TO BE 20 GA MIN.



MINIMUM STEEL DECK REQUIREMENTS

MINIMUM STEEL DECK REQUIREMENTS



Degenkolb
OSHDP PRE-APPROVAL OF MANUFACTURER CERTIFICATION
OPM-0187 - 13



DEGENKOLB ENGINEERS
225 Montgomery Street, Suite 500
San Francisco, CA 94104
415.392.8652 Phone
415.981.3157 Fax
www.degenkolb.com

OMNICELL
YUYAMA MODELS 260, 336 AND 520

CASE 2 - EQUIPMENT AT OR BELOW GRADE

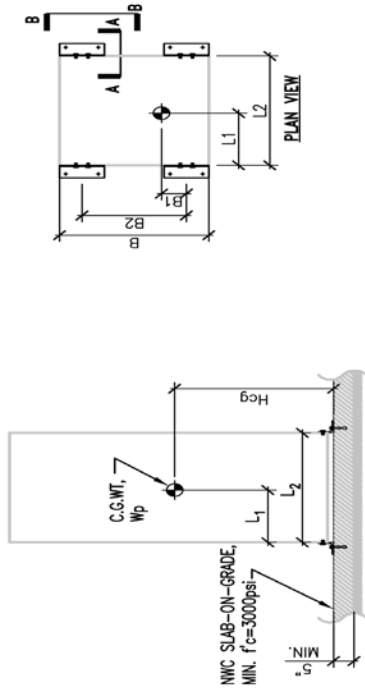

FRONT ELEVATION
YUYAMA MODELS 260, 336, 520

OMNICELL	Wp (LBS)	L1 (IN)	L2 (IN)	B (IN)	B1 (IN)	B2 (IN)	H (IN)	Hcg (IN)
MODEL 260:	1530	16.7	35.0	36.6	6.1	25.6	78.7	36.7
MODEL 336:	1930	23.5	50.8	36.6	7.9	25.6	78.7	38.0
MODEL 520:	3007	35.0	70.0	36.6	9.0	25.6	78.7	38.6

NOTES:

- ANCHORAGE DESIGN CONFORMS TO THE 2013 CALIFORNIA BUILDING CODE. FORCES GIVEN ARE FACTORED LOADS THAT SHALL BE USED FOR STRENGTH DESIGN.
- SEE GENERAL NOTES SECTION PAGE 1.
- SEE PAGE 4 FOR FORCE DEMANDS APPLIED TO THE SUPPORTS AND ATTACHMENTS.
- S.E.O.R. MAY RECALCULATE MAX. ANCHOR FORCES AT THEIR DISCRETION BASED ON PROJECT SPECIFIC SEISMIC DEMANDS. SUBJECT TO OSHDP REVIEW/PERMIT.
- PROVIDE HEX NUT AT TOP AND BOTTOM OF STRUT FLANGE, TYP., U.O.N. AT CONDITIONS WHERE NUT CANNOT BE PROVIDED AT TOP SIDE OF STRUT, PROVIDE TAPPED HOLE THROUGH STRUT FLANGE.
- SEOR SHALL PROVIDE STRUCTURE TO SUPPORT WEIGHTS AND FORCES SHOWN IN COMBINATION WITH ALL OTHER LOADS THAT MAY BE PRESENT.
- TOTAL WEIGHT (Wp) IS A MAXIMUM. THIS PRE-APPROVAL ENCOMPASSES ALL WEIGHTS UP TO THE MAXIMUM SHOWN.
- EQUIPMENT MANUFACTURER MUST DESIGN UNIT TO MAKE Hcg EQUAL OR LESS THAN THE HEIGHT DIMENSION SHOWN.

Fu=33 ksi, MIN. SHEET METAL THICKNESS:
MODEL 260, 520: 3 LAYERS, EACH 0.063" THK
MODEL 336: 0.063"

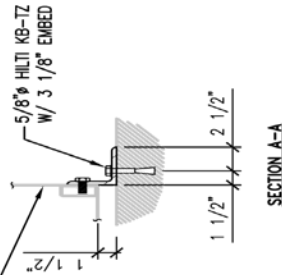

SECTION A-A

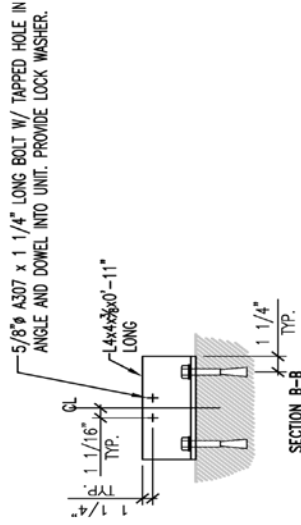

SECTION B-B



OMNICELL
YUYAMA MODELS 260, 336 AND 520

OSHPD PRE-APPROVAL OF MANUFACTURER CERTIFICATION
OPM-0187 - 13



DEGENKOLB ENGINEERS
238 Montgomery Street, Suite 500
San Francisco, CA 94104
415.382.6952 Phone
415.981.3157 Fax
www.degenkolb.com

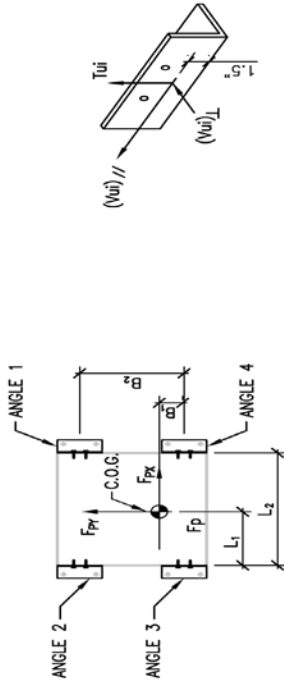

DIMENSIONAL DATA

	Wp (LBS)	L ₁ (IN)	L ₂ (IN)	B ₁ (IN)	B ₂ (IN)	Hcg (IN)
MODEL 260:	1530	16.7	35.0	6.1	25.6	36.7
MODEL 336:	1930	23.5	50.8	7.9	25.6	38.0
MODEL 520:	3007	35.0	70.0	9.0	25.6	38.6

FORCES WHEN Z/H = 0.0 (LBS)

	FOR F _p X		FOR F _p Y		FOR F _{pX} + 0.3F _{pY}		FOR 0.3F _{pX} + F _{pY}	
	Tu	Vu _L	Tu	Vu _H	Tu _L	Vu _L	Tu	Vu _H
MODEL 260:	1159	656	1069	450	1541	656	1481	197
MODEL 336:	864	751	1473	583	1384	751	1810	225
MODEL 520:	873	1097	2220	847	1640	1097	2582	329

FORCES WHEN Z/H ≤ 1.0 (LBS)

	FOR F _p X		FOR F _p Y		FOR F _{pX} + 0.3F _{pY}		FOR 0.3F _{pX} + F _{pY}	
	Tu	Vu _L	Tu	Vu _H	Tu _L	Vu _L	Tu	Vu _H
MODEL 260:	3445	1748	3219	1200	4477	1748	4319	524
MODEL 336:	2736	2002	4360	1556	4121	2002	5285	601
MODEL 520:	2887	2925	6476	2258	4930	2925	7443	877

1. ANCHORAGE DESIGN CONFORMS TO THE 2013 CALIFORNIA BUILDING CODE. FORCES GIVEN ARE FACTORED LOADS THAT SHALL BE USED FOR STRENGTH DESIGN.
2. FOR THE SUPPORT AND ATTACHMENT DESIGN, THE MOST CRITICAL LOAD COMBINATION IS $(0.9 - 0.25s_d)XOL \pm F_p$
3. SEE GENERAL NOTES SECTION PAGE 1.
4. S.E.O.R. MAY RECALCULATE MAX. ANCHOR FORCES AT THEIR DISCRETION BASED ON PROJECT SPECIFIC SEISMIC DEMANDS SUBJECT TO OSHPD REVIEW/PERMIT.
5. PROVIDE HEX NUT AT TOP AND BOTTOM OF STRUT FLANGE. TYP. U.O.N. AT CONDITIONS WHERE NUT CANNOT BE PROVIDED AT TOP SIDE OF STRUT, PROVIDE TAPPED HOLE THROUGH STRUT FLANGE.
6. SEOR SHALL PROVIDE STRUCTURE TO SUPPORT WEIGHTS AND FORCES SHOWN IN COMBINATION WITH ALL OTHER LOADS THAT MAY BE PRESENT.
7. TOTAL WEIGHT (Wp) IS A MAXIMUM. THIS OPM ENCOMPASSES ALL WEIGHTS UP TO THE MAXIMUM SHOWN.
8. EQUIPMENT MANUFACTURER MUST DESIGN UNIT TO MAKE Hcg EQUAL OR LESS THAN THE HEIGHT DIMENSION SHOWN.
4. T_u IS THE MAXIMUM TENSION CALCULATED FOR EACH LOAD CASE FOR ALL ANGLES
5. V_u IS THE MAXIMUM SHEAR FORCE CALCULATED FOR EACH LOAD CASE FOR ALL ANGLES
6. T_u, V_{uL} AND V_{uH} FORCES SHOWN ON THE TABLES ARE AT STRENGTH LEVEL AND HAVE NOT BEEN AMPLIFIED BY Ω_c. FOR ANCHORAGE TO CONCRETE LOADS ARE REQUIRED TO BE AMPLIFIED BY Ω_c.

Appendix C: Cybernet iOne H19 Workstation Specifications

The Cybernet iOne H19 workstation is used with several Omnicell products listed below.

- Central Pharmacy (CP)
- Controlled Substance Management (CSM)
- Open Supply
- OptiFlex
- WorkflowRx

This table describes the specifications for the workstation.

CPU Support	Intel® Core™ i3, i5 & i7 processors
Motherboard Core Logic	Intel® H61 Express chipset (Sandy Bridge)
Memory	2 x DDR3 204-pin SO-DIMM sockets, populated up to 8GB Max. Supports PC3-10600 1333MHz SO-DIMM
HDD Support	Integrated Serial ATA controller facilitates high-speed transfers up to 3Gbps for each of the four ports
Video & Graphics	nVidia GPU with dedicated memory or The Intel® integrated H61 Chipset, with Intel® HD Graphics (Intel® GMA HD), includes built-in support for full 1080p HD. Maximum resolution: 2560 x 1600
Networking	Dual Gigabit (Gbe) Fast Ethernet, Realtek RTL 8111E
Audio	Realtek ALC892 High Definition Audio enables premium Dolby Digital 5.1 surround sound, 10 channels of enhanced sound quality, and delivers advanced features such as multiple audio streams and jack re-tasking.
I/O Ports	<ul style="list-style-type: none"> - 2 X USB 3.0 ports, 4 x USB 2.0 ports - 1 x RS232 serial port, option to expand to 3 COM ports - DVI-I monitor out port - HDMI Full 1080p

Touchscreen	Optional single touch
Wireless	802.11 b/g/n + Bluetooth
Expansion Slots	Two Mini PCI-e (1xFull-size and 1xHalf-size)
System BIOS	AMI Flash BIOS supports ACPI, API, DMI, Plug & Play, and security password. Supports booting from HDD, PXE, LAN, CD-ROM, and ANY USB device.
Power Supply	120 Watt AC Adapter. Input: universal, 100 ~ 240V AC, 50-60Hz. Supports Output range:, DC12V/19V. 5.0A/9.5A Adapters for Energy Star 5.0/UL
BIOS Security	AMI BIOS System POST and BIOS setup password protection
Security Lock	Security lock slot located on the back of the system case
Swivel Base	System Base enables left/right rotation up to 60°. Tilt from -5 to 60°
Wall Mount	Supports both 75 mm & 100 mm VESA mounting holes
Dimensions	17" W x 15.8" H x 3.2" D (43.18 x 40.13 x 8.13 cm)
Weight	Unit: 22.9 lb (10.39 kg) with base, 17 lb (7.71 kg) without base, Power Adapter: 2.2 lb (1.0 kg)
Operating Environment	Ambient Temperature: 0°C ~ 50°C (operating)
Relative Humidity	10% ~ 90% (non-condensing)
Operating System	Microsoft Windows 7 (32-bit), Windows 8 (32-bit), Linux
Available Colors	Black
Certifications	FCC Class B, CE, UL60950, Energy Star 5.2, RoHS, WEEE